

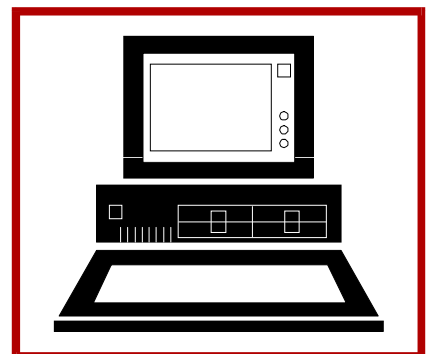

40 Series

Instruction

Operation Operator Interface Station (Release J)

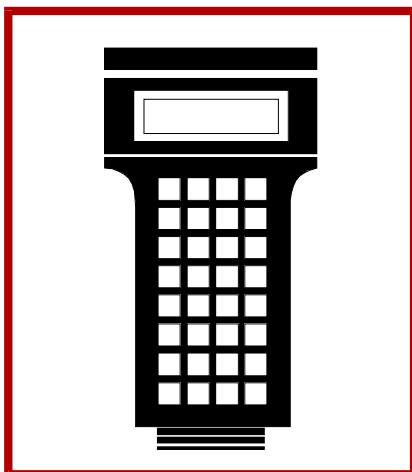
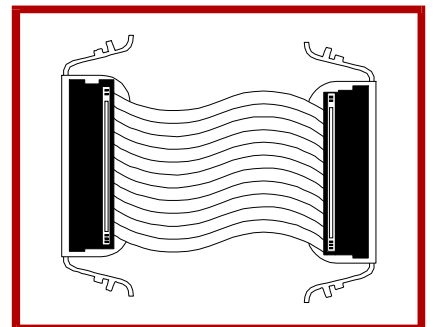
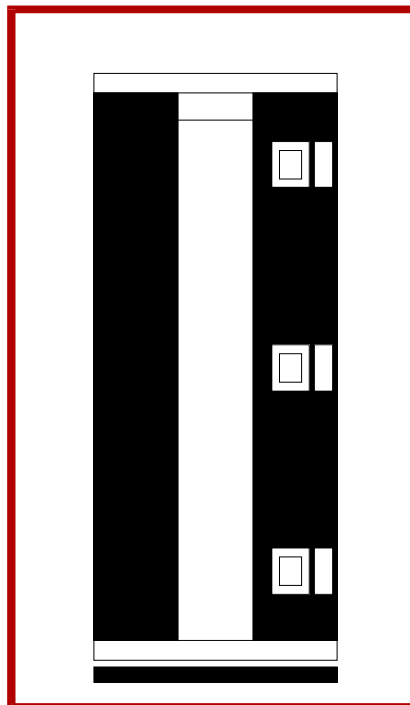
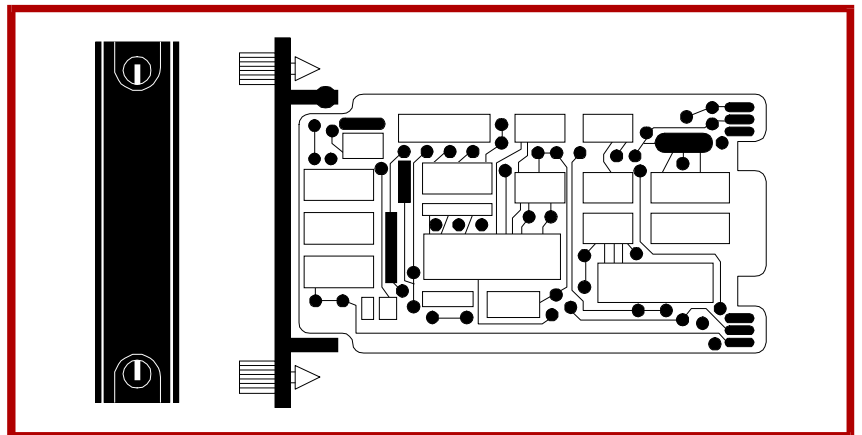
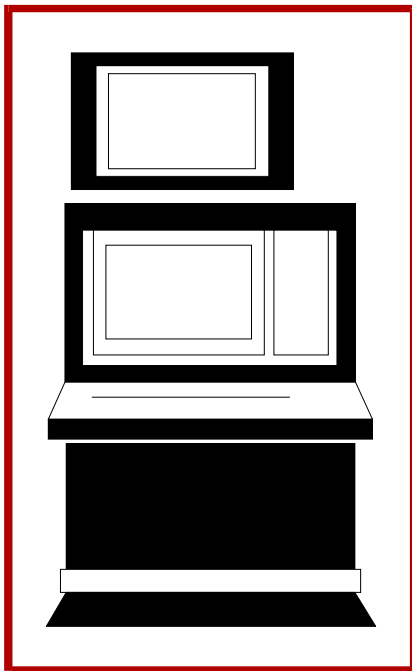

WARNING notices as used in this instruction apply to hazards or unsafe practices that could result in personal injury or death.

CAUTION notices apply to hazards or unsafe practices that could result in property damage.

NOTES highlight procedures and contain information that assists the operator in understanding the information contained in this instruction.

WARNING

INSTRUCTION MANUALS

DO NOT INSTALL, MAINTAIN, OR OPERATE THIS EQUIPMENT WITHOUT READING, UNDERSTANDING, AND FOLLOWING THE PROPER **Elsag Bailey** INSTRUCTIONS AND MANUALS; OTHERWISE, INJURY OR DAMAGE MAY RESULT.

RADIO FREQUENCY INTERFERENCE

MOST ELECTRONIC EQUIPMENT IS INFLUENCED BY RADIO FREQUENCY INTERFERENCE (RFI). CAUTION SHOULD BE EXERCISED WITH REGARD TO THE USE OF PORTABLE COMMUNICATIONS EQUIPMENT IN THE AREA AROUND SUCH EQUIPMENT. PRUDENT PRACTICE DICTATES THAT SIGNS SHOULD BE POSTED IN THE VICINITY OF THE EQUIPMENT CAUTIONING AGAINST THE USE OF PORTABLE COMMUNICATIONS EQUIPMENT.

POSSIBLE PROCESS UPSETS

MAINTENANCE MUST BE PERFORMED ONLY BY QUALIFIED PERSONNEL AND ONLY AFTER SECURING EQUIPMENT CONTROLLED BY THIS PRODUCT. ADJUSTING OR REMOVING THIS PRODUCT WHILE IT IS IN THE SYSTEM MAY UPSET THE PROCESS BEING CONTROLLED. SOME PROCESS UPSETS MAY CAUSE INJURY OR DAMAGE.

NOTICE

The information contained in this document is subject to change without notice.

Elsag Bailey, its affiliates, employees, and agents, and the authors and contributors to this publication specifically disclaim all liabilities and warranties, express and implied (including warranties of merchantability and fitness for a particular purpose), for the accuracy, currency, completeness, and/or reliability of the information contained herein and/or for the fitness for any particular use and/or for the performance of any material and/or equipment selected in whole or part with the user of/or in reliance upon information contained herein. Selection of materials and/or equipment is at the sole risk of the user of this publication.

This document contains proprietary information of Elsag Bailey, Elsag Bailey Process Automation, and is issued in strict confidence. Its use, or reproduction for use, for the reverse engineering, development or manufacture of hardware or software described herein is prohibited. No part of this document may be photocopied or reproduced without the prior written consent of Elsag Bailey.

This instruction provides general information that overviews an Signature Series Work Station or 40 Series Operator Interface Station. It also includes specific information necessary to operate the console. The instruction reflects the J.1 software release for the console.

NOTE: In this instruction 40 series and console refer to only the IIOIS42, IIOIS43, IIOIS42^{PLUS}, IIOIS41^{PLUS2}, and Signature IS42, IS43, and IS42^{PLUS} consoles.

There are three additional instructions that explain how to set up and use the console:

- | | |
|-----------------------|--|
| Hardware | Provides hardware installation, troubleshooting, maintenance, repair, and replacement procedures. |
| File Utilities | Provides software load, upgrade, and maintenance procedures, and provides save and restore configuration procedures. |
| Configuration | Gives the procedures to configure the console as a system for proper operation with its peripherals and the INFI 90 [®] OPEN system. It also explains each console function, gives configuration procedures, and explains configuration requirements. |

Besides operation information, this instruction also provides information about those configurations performed outside the OIS application such as touch pad, touch screen, and screen copy printer configuration. These are windows applications.

In addition to standard console functions, this instruction discusses certain functions that apply to systems, such as @aGlance/IT[™], that are only available to meet unique plant requirements. Unless applicable to your plant operations, disregard the options that support these nonstandard systems and the sections in this instruction that describe the options.

List of Effective Pages

Total number of pages in this instruction is 551 consisting of the following:

Page No.	Change Date
Preface	Original
List of Effective Pages	Original
iii through xix	Original
1-1 through 1-14	Original
2-1 through 2-24	Original
3-1 through 3-14	Original
4-1 through 4-11	Original
5-1 through 5-8	Original
6-1 through 6-14	Original
7-1 through 7-15	Original
8-1 through 8-42	Original
9-1 through 9-27	Original
10-1 through 10-26	Original
11-1 through 11-8	Original
12-1 through 12-22	Original
13-1 through 13-25	Original
14-1 through 14-26	Original
15-1 through 15-11	Original
16-1 through 16-18	Original
17-1 through 17-7	Original
18-1 through 18-23	Original
19-1 through 19-60	Original
20-1 through 20-13	Original
21-1 through 21-32	Original
22-1 through 22-29	Original
A-1	Original
B-1 through B-58	Original
Index-1 through Index-7	Original

When an update is received, insert the latest changed pages and dispose of the superseded pages.

NOTE: On an update page, the changed text or table is indicated by a vertical bar in the outer margin of the page adjacent to the changed area. A changed figure is indicated by a vertical bar in the outer margin next to the figure caption. The date the update was prepared will appear beside the page number.

Table of Contents

	<i>Page</i>
SECTION 1 - INTRODUCTION	1-1
OVERVIEW	1-1
CONSOLE TYPES	1-1
INTENDED USER.....	1-1
DESCRIPTION.....	1-2
DECstation.....	1-3
Driver Unit.....	1-3
Color Monitor.....	1-4
Keyboard Interface Panel.....	1-4
Keyboard	1-5
Annunciator Display Panel.....	1-5
Disk Drives	1-6
Power Entry Panel.....	1-6
Printers.....	1-6
FEATURES.....	1-7
INSTRUCTION CONTENT	1-8
HOW TO USE THIS INSTRUCTION	1-10
DOCUMENT CONVENTIONS	1-11
GLOSSARY OF TERMS AND ABBREVIATIONS	1-12
REFERENCE DOCUMENTS.....	1-14
SECTION 2 - SYSTEM AND CONSOLE OVERVIEW	2-1
INTRODUCTION.....	2-1
INFI 90 OPEN SYSTEM OVERVIEW	2-1
Communication Highway	2-1
Process Control Unit	2-2
Operator Interface Station	2-3
Network Interface Unit	2-4
Engineering Work Station	2-4
FUNCTIONS	2-5
Operations Interface.....	2-5
Security Management	2-6
Database	2-6
Alarm Management.....	2-7
Process Trending.....	2-9
Trend Display	2-9
XY Graph.....	2-9
Operator Assignable.....	2-10
Logging	2-10
Custom Logs.....	2-10
Sequence of Events Log.....	2-11
System Event Log	2-11
Archival Storage and Retrieval.....	2-11
System Status and Diagnostics	2-12
System Tuning and Configuration	2-12
Display Configurator	2-12
Operator Configurable Displays.....	2-13
Alternate Language	2-13
OPERATING THEORY.....	2-13
Control Engineering	2-15
Plant Operation.....	2-15
Summary and Status Displays	2-16
Process Monitoring and Control Displays	2-17

Table of Contents (continued)

	<i>Page</i>
<hr/>	
SECTION 2 - SYSTEM AND CONSOLE OVERVIEW (continued)	
System Troubleshooting	2-18
TRENDING	2-18
Distributed Trending	2-18
Standard Trending (FC 66)	2-19
Enhanced Trending (FC 179)	2-19
Local Trend Data Collection	2-20
Remote Trend Data Collection	2-21
TIME-STAMP	2-22
Exception Report	2-22
Console	2-23
USER TASKS	2-23
@aGlance/IT	2-23
User Task Interface.....	2-24
<hr/>	
SECTION 3 - KEYBOARD AND PERIPHERALS	3-1
INTRODUCTION	3-1
KEYBOARDS	3-1
Keyboard Operation.....	3-1
Keyboard Error	3-2
KEYBOARD LAYOUT	3-3
Display Control	3-3
Alphabetic Characters	3-6
Numeric Keypad	3-6
Cursor and Trend Control.....	3-7
Station and Remote Control.....	3-8
Assignable Function Keys	3-10
Alarm Acknowledge and Silence	3-10
ANNUNCIATOR DISPLAY PANEL.....	3-11
PRINTERS	3-11
Printer Assignment.....	3-12
Printer Assignment Option	3-12
ASGN PRN Option	3-12
Shared and Private Printers	3-13
Shared Printer.....	3-13
Private Printer	3-13
Printer Error or Failure.....	3-14
Printer Failover.....	3-14
<hr/>	
SECTION 4 - DISPLAY SYSTEM	4-1
INTRODUCTION	4-1
DISPLAY SYSTEM.....	4-1
Display Characteristics.....	4-3
Title Line Display Elements	4-4
Alarm Priority Indicators	4-6
Bottom Line Display Elements	4-7
Keyboard Status.....	4-8
User Space.....	4-9
Color Scheme	4-9
Display Element Escape Commands	4-10

Table of Contents (continued)

	<i>Page</i>
SECTION 5 - MENU STRUCTURE.....	5-1
INTRODUCTION.....	5-1
GENERAL FUNCTIONS MENU.....	5-1
MISCELLANEOUS MENU.....	5-8
COMMAND LINE MENU.....	5-8
SECTION 6 - WINDOWS SYSTEM.....	6-1
INTRODUCTION.....	6-1
OIS APPLICATION AND OIS UTILITIES.....	6-1
USING THE MOUSE.....	6-2
Moving Between Screens.....	6-2
Mouse Buttons.....	6-2
WINDOW LAYOUT.....	6-2
Title Bar.....	6-3
Menu Bar.....	6-4
Utilities Option.....	6-5
Operations Option.....	6-5
Displays Option.....	6-5
Work Area.....	6-6
Title Bar Buttons.....	6-6
Icons.....	6-7
Resize Border Handles.....	6-7
USING SHORTCUT KEYS.....	6-7
Minimize a Window.....	6-7
Maximize a Window.....	6-8
Size a Window.....	6-8
Move a Window.....	6-8
Close a Window.....	6-8
WORKSPACE MENU.....	6-9
SIZING AN OIS APPLICATION WINDOW.....	6-9
AUXILIARY CONSOLES.....	6-9
IIOIC42 Console.....	6-10
OIS Session Manager Start-Up.....	6-10
Calling Multiple Session Managers.....	6-11
IIOIC41 Console.....	6-12
SESSION MANAGER.....	6-12
OPENING A WINDOW ON THE UPPER SCREEN.....	6-14
SECTION 7 - GENERAL OPERATIONS.....	7-1
INTRODUCTION.....	7-1
OPERATING THE OIS APPLICATION.....	7-1
KEY LOCK.....	7-1
SECURITY PASSWORD.....	7-2
Log-In.....	7-2
Log-Out.....	7-3
DATA INPUT.....	7-4
Making a Field Active.....	7-4
Inputting Data.....	7-5
Input Field Error Checking.....	7-5
Entering Alternate Language Characters.....	7-5
Extended Characters.....	7-6
Complex Characters.....	7-6

Table of Contents (continued)

	<i>Page</i>
SECTION 7 - GENERAL OPERATIONS (continued)	
ACCESSING DISPLAYS	7-7
Menu Items	7-7
Display Summary	7-7
Keyboard and Annunciator Display Panel Access	7-7
Display by Name Access	7-8
Automatic Displays or Pop Up Elements	7-8
Activating an Automatic Display Set	7-9
Deactivating an Automatic Display Set	7-9
User Task Activated	7-9
Redirecting a Display Call-Up	7-10
Display Paging	7-11
Back and Forward Keys	7-11
Mark and Recall Keys	7-12
Next Page and Previous Page Keys	7-12
DISPLAY AND CONTROL SELECT OPTIONS	7-12
Touch Screen	7-13
Mouse or Trackball	7-13
Control Select Highlighting	7-14
Pop Up Control	7-14
CALCULATOR	7-15
NOTE	7-15
SECTION 8 - WINDOWS APPLICATIONS AND UTILITIES.....8-1	
INTRODUCTION	8-1
MESSAGE WINDOW	8-1
MAIL.....	8-2
LOG-IN WINDOW.....	8-2
SCREEN COPY	8-3
Screen Copy Printers	8-3
Print Node	8-3
Screen Copy Configuration Utility	8-4
Selecting a Printer	8-5
Configuring a Printer	8-5
Queue Name	8-7
Print Attributes	8-7
Considerations	8-8
Screen Copy Printer Failover.....	8-8
Initiating a Screen Copy.....	8-10
Command Line Menu Print Option	8-11
Pull-Down Menu Screen Copy Option	8-11
Setting the Number of Copies.....	8-12
Canceling a Queued Screen Copy.....	8-12
Screen Copy Color Map Utility	8-12
Setting Up a Color Swap	8-13
Color Swap Considerations	8-14
TOUCH SCREEN	8-14
Using the Touch Screen	8-15
Touch Screen Setup Utility	8-15
Touch Screen Options	8-16
Calibration	8-18
IIOIC42 Touch Screen Setup.....	8-20
IIOIC42 Calibration	8-22

Table of Contents (continued)

	<i>Page</i>
<hr/>	
SECTION 8 - WINDOWS APPLICATIONS AND UTILITIES (continued)	
TOUCH PAD	8-23
OIS Application Configuration Requirements	8-25
Touch Pad Configuration Utility	8-25
IIOIC42 Touch Pads	8-25
Configuring Touch Pads	8-26
Using a Touch Pad	8-29
CONFIGURING THE MOUSE CURSOR	8-29
Selecting a Mouse Cursor Style	8-30
Change Mouse Cursor Colors	8-30
CONFIGURING THE OIS WINDOW ENVIRONMENT	8-33
Selecting Windows Capabilities/Features	8-34
CONFIGURING THE MENU BAR.....	8-35
Main Configuration Window	8-35
Display Configuration Dialog Box	8-38
Menu Label Configuration Dialog Box	8-40
OIS Standard Function Menu Configuration Dialog Box	8-41
OIS Function Configuration Dialog Box	8-41
<hr/>	
SECTION 9 - PROCESS CONTROL	9-1
INTRODUCTION	9-1
PROCESS CONTROL FUNCTIONS	9-1
Control Faceplates	9-1
Control Tags	9-2
Control Actions	9-2
Control Inhibit	9-3
Common Control Element Attributes	9-3
Loop Control	9-6
Station Element	9-6
STATION Control	9-10
Device Control	9-13
Remote Control Memory Element	9-13
RCM Control.....	9-14
Remote Manual Set Constant Element	9-15
RMSC Control.....	9-17
Device Driver Element.....	9-17
DD Control	9-19
Multi-State Device Driver Element	9-20
MSDD Control	9-22
Remote Motor Control Block Element	9-23
RMCB Control	9-26
<hr/>	
SECTION 10 - DATA ACQUISITION	10-1
INTRODUCTION	10-1
DATA ACQUISITION FUNCTIONS	10-1
Data Acquisition Faceplates	10-1
Data Acquisition Tags	10-2
Control Actions	10-2
Control Inhibit	10-3
Common Data Acquisition Element Attributes	10-3
Analog Element.....	10-6
Analog Element Attributes	10-7

Table of Contents (continued)

	<i>Page</i>
<hr/>	
SECTION 10 - DATA ACQUISITION (continued)	
ANALOG Control	10-8
Digital Element.....	10-8
Digital Element Attributes	10-10
DIGITAL Control.....	10-10
Data Acquisition Analog Element	10-11
DANG Element Attributes.....	10-11
DANG Control	10-15
Data Acquisition Digital Element	10-16
DADIG Element Attributes	10-17
DADIG Control	10-19
Text String Element	10-20
TEXTSTR Element Attributes.....	10-21
TEXTSTR Control	10-23
<hr/>	
SECTION 11 - TUNING AND BLOCK DETAILS.....	11-1
INTRODUCTION	11-1
TUNING FUNCTIONS	11-1
BLOCK DETAILS	11-1
Calling the Block Details Display	11-2
Tag or Block Address	11-2
Tag Element	11-3
Block Details Operations	11-3
TUNING DISPLAY	11-5
Calling the Tuning Display.....	11-6
Tag.....	11-6
Tag Element	11-7
Tuning Display Operations	11-7
<hr/>	
SECTION 12 - ALARM MANAGEMENT	12-1
INTRODUCTION	12-1
ALARM INDICATIONS	12-1
Process Alarms	12-3
System Alarms	12-3
Alarm Status Field.....	12-4
Alarm Status Descriptors	12-4
DANG Tag	12-6
Quality Indicators	12-6
Alarm Group Indicators	12-8
Alarm Priority Indicators and Descriptors	12-8
RE-ALARMING.....	12-9
ALARM SUPPRESSION	12-10
BAD QUALITY ALARMING.....	12-10
ALARM PROCESSING PROCEDURES	12-10
Silencing an Alarm Tone	12-11
Silencing an External Annunciator	12-12
Acknowledging an Alarm	12-12
Correcting an Alarm Condition	12-13
ALARM SUMMARY.....	12-14
Sorting	12-14
Return-to-Normal Alarms	12-14
System Status Alarms	12-14

Table of Contents (continued)

	<i>Page</i>
<hr/>	
SECTION 12 - ALARM MANAGEMENT (continued)	
Alarm Summary Attributes	12-15
Alarm Summary Element	12-16
Alarm Summary Operations	12-17
Calling an Alarm Summary	12-17
Activating a Summary	12-18
Paging Through Entries	12-18
Acknowledging an Alarm	12-18
Processing a Return-to-Normal	12-19
Calling a Primary Display	12-19
ALARM GROUP INHIBIT	12-19
Selecting the First Group	12-21
Inhibiting Individual Groups	12-22
Inhibiting a Range of Groups	12-22
<hr/>	
SECTION 13 - TAG OPERATIONS	13-1
INTRODUCTION	13-1
OPERATING PARAMETERS	13-1
Calling the Operating Parameters Page	13-2
Common Tag Information	13-3
Tag Specific Information	13-5
Display Operations	13-9
Scan Off/On	13-9
Alarm Inhibit/Enable	13-9
Primary Display	13-9
Substitute Value	13-10
Block Details	13-12
Tuning	13-12
Problem Report	13-12
Suppress/Allow Alarms	13-12
On/Off Report	13-13
Force Report	13-13
Latch Reset	13-13
TAG SUMMARIES	13-13
Setting the Tag Range	13-16
Setting the Search Pattern	13-16
Summary Options	13-17
Selecting an Option	13-19
Display	13-19
Print	13-19
Perform a Custom Query	13-20
PRINT TAG LIST	13-22
Setting the Tag Range	13-23
Setting the Search Pattern	13-24
Selecting the Tags to Print	13-24
<hr/>	
SECTION 14 - TREND OPERATIONS	14-1
INTRODUCTION	14-1
TREND DATA SOURCE	14-1
TREND DISPLAY	14-1
Display Resolution	14-2
Display Updates	14-3

Table of Contents (continued)

	<i>Page</i>
<hr/>	
SECTION 14 - TREND OPERATIONS (continued)	
Trend Attributes	14-3
Time Cursor	14-6
Time Span	14-6
TREND CONTROL.....	14-6
Enabling Trend Control	14-7
Moving the Time Cursor.....	14-7
Modifying the Scale Range	14-8
Panning.....	14-9
Zooming	14-10
Using the Magnifying Glass.....	14-12
OPERATOR ASSIGNABLE TRENDS	14-13
Operator Assignable Trends Display	14-13
Trend Assignments	14-14
Operator Trend Assignment Option	14-15
Automatic Trend Assignments	14-18
Operator Assignable Trend Assignments Window	14-19
Calling the Trend Display	14-22
PRINT TREND LIST	14-23
Setting the Range	14-23
Selecting the Trends to Print	14-24
List by Tag Name	14-25
List by Trend Type	14-25
List by Collection Mode.....	14-25
List by Trend Usage	14-26
List by Module Address	14-26
List by Tag Type	14-26
<hr/>	
SECTION 15 - XY PLOT OPERATIONS	15-1
INTRODUCTION	15-1
TAG OR TREND XY PLOT	15-1
Plot Display	15-1
Plot Attributes	15-2
Plot Control	15-4
Selecting a Plot.....	15-4
Setting the Scale Limits	15-4
Changing the Mode	15-4
Calling Help	15-5
Plot Data Background Curve.....	15-5
Saving Plot Coordinates to a File.....	15-6
Editing a File.....	15-6
Displaying a Background File	15-7
Clearing a Background Curve	15-7
Trend History	15-7
MFC DATA SOURCE XY PLOT.....	15-8
Plot Display	15-9
Plot Attributes	15-9
Plot Control	15-10
<hr/>	
SECTION 16 - OPERATOR CONFIGURABLE DISPLAYS	16-1
INTRODUCTION	16-1
OPERATOR DISPLAYS	16-1

Table of Contents (continued)

	<i>Page</i>
<hr/>	
SECTION 16 - OPERATOR CONFIGURABLE DISPLAYS (continued)	
Control and Data Acquisition Elements	16-1
Trend Element	16-3
Alarm Summary Element	16-3
Creating a Display.....	16-3
Directory Page	16-4
Edit Page	16-5
Selecting a Box	16-6
Defining an Element	16-6
Saving to a File	16-7
Deleting a Display File	16-7
Box Overlap	16-8
Defining a Control or Data Acquisition Element	16-8
Defining a Trend Element.....	16-12
Defining an Alarm Summary Element	16-15
Making an Operator Configurable Display Permanent	16-17
Making Room for Additional Displays	16-18
<hr/>	
SECTION 17 - OPERATOR ACTIONS AND INFORMATION.....	17-1
INTRODUCTION.....	17-1
OPERATOR ACTION REQUESTS	17-1
Calling the Operator Action Requests Page	17-1
Processing an Action Request.....	17-3
Enabling the Action Requests Page.....	17-3
Paging Through Entries.....	17-4
Acknowledging a Request	17-4
OPERATOR INFORMATION EVENTS	17-5
Enabling the Information Events Page	17-6
Paging Through Entries.....	17-6
Deleting Entries	17-6
<hr/>	
SECTION 18 - LOGS	18-1
INTRODUCTION.....	18-1
LOGGING.....	18-1
System Event Log.....	18-1
Custom Logs.....	18-2
SOE Logs	18-2
PRINTING AND DISPLAYING LOGS	18-3
Display Log Operations	18-4
Custom Configured Logs	18-5
Generating Sequence of Events Summary Logs	18-6
Sequence of Events Logs	18-8
Printing the Events and Operator Actions Logs	18-8
Displaying the System Event Log.....	18-9
Calling in Real-Time Mode	18-10
Calling in Snapshot Mode	18-10
Calling the Display and Selecting the Mode	18-12
Specifying a Search Criteria	18-12
LOG STATUS.....	18-14
Selecting a Start Log	18-16
Custom Logs Status Page	18-16
SOE Logs Status Page	18-18

Table of Contents (continued)

	<i>Page</i>
<hr/>	
SECTION 18 - LOGS (continued)	
Status Page Operations	18-19
Action Menu Operations	18-20
Activating Logs	18-20
Deactivating Logs	18-21
Canceling Waiting Log Prints	18-22
<hr/>	
SECTION 19 - ARCHIVE DATA	19-1
INTRODUCTION	19-1
ARCHIVING	19-1
ARCHIVE DATA STORAGE	19-2
Disk Space	19-3
Data Type Storage	19-3
Scheduling an Archive	19-3
Setting Up Archival Storage	19-4
Hard Disk Data Storage	19-5
Media Storage	19-6
Open Access System Storage	19-6
Data Type to Volume Definition	19-6
Volume To Media Definition	19-8
Archive Scheduling Using Volume to Media	19-11
Miscellaneous Definitions	19-12
Setting Up Data to be Archived	19-15
Events	19-15
Trend Data	19-16
Custom Logs	19-16
Sequence of Events Logs	19-17
PCU Configurations	19-17
Tag Data	19-17
Store Data	19-21
Use New Volume	19-23
Responding to an Action Request	19-24
Archival Error Recovery	19-25
ARCHIVE DATA RETRIEVAL	19-25
Requesting a Directory of an Archive Volume	19-26
Retrieving Data by Type	19-28
System Events	19-31
Logs	19-31
Tag Data	19-34
Trend Data	19-35
PCU Configurations	19-40
Requesting a Directory of Retrieved Data	19-41
Tag Data	19-42
Trend Data	19-43
PCU Configurations	19-44
Deleting Retrieved Data from the Directory Page	19-44
Viewing or Printing Retrieved Archive Data	19-45
Tag Data	19-46
Trend Data	19-46
PCU Configurations	19-46
Tag Historian	19-46
Requesting a Tag Historian Data Retrieval	19-48
Printing or Deleting Retrieved Tag Data	19-56

Table of Contents (continued)

	<i>Page</i>
SECTION 20 - UTILITIES	20-1
INTRODUCTION	20-1
SET DATE AND TIME	20-1
System and Local Time	20-1
Time Synchronization	20-2
Important Considerations	20-4
Setting the Date and Time	20-4
INFI-NET Date and Time	20-6
Time Maintenance Options	20-6
Date and Time Requirements	20-7
Example INFI-NET Time Setting	20-8
Plant Loop Date and Time	20-9
Time Maintenance Options	20-9
Date and Time Requirements	20-10
CANCELING QUEUED PRINT JOBS	20-11
SECTION 21 - SYSTEM DIAGNOSTICS.....	21-1
INTRODUCTION.....	21-1
SYSTEM STATUS DISPLAYS.....	21-1
Calling the Status Display	21-2
System Status Hierarchy.....	21-2
System Status Overview Page	21-3
Node Status Summary Page	21-5
Module Status Summary Page.....	21-9
Module Status Bytes	21-11
Module Problem Reports	21-12
Acknowledging System Status Alarms	21-12
MODULE FIRMWARE REVISION DISPLAY.....	21-13
Display Attributes	21-14
Operations.....	21-15
Module Revision Levels	21-15
Options	21-16
INFI-NET DIAGNOSTICS	21-17
Calling the Diagnostics Menu	21-18
Selecting a Loop and Node.....	21-19
Using the Select Loop, Node, and Sort Option	21-20
Using the Select Loop and Node for Display Option	21-20
Using the Menu Options.....	21-21
Loop Topology.....	21-21
Node Topology	21-23
Communication Module Details	21-25
Event and Error Counters	21-26
Exception Statistics	21-27
Print Network Topology	21-29
Printing Diagnostics Information	21-30
Screen Print.....	21-30
Print Options	21-30
Updating Diagnostics Information	21-31
SECTION 22 - SYSTEM MANAGEMENT.....	22-1
INTRODUCTION.....	22-1
PCU CONFIGURATION ACCESS	22-1

Table of Contents (continued)

	<i>Page</i>
<hr/>	
SECTION 22 - SYSTEM MANAGEMENT (continued)	
PCU CONFIGURATION MENU	22-1
Module Configuration Option	22-2
Configuring or Tuning a Module	22-2
Selecting a Loop, PCU, and Module	22-4
Changing Module Mode	22-4
Modifying a Function Block	22-5
Adding a Function Block	22-5
Deleting a Function Block	22-6
Tuning a Function Block	22-6
Copying a Function Block	22-6
Moving a Function Block	22-7
Finding a Module Function Code	22-7
Displaying the Module Functions Blocks	22-8
Viewing a Function Code List	22-8
PCU Management Option	22-8
Using PCU Management	22-9
Selecting Loop, PCU, Modules, and Media	22-10
Changing Module Mode	22-12
Saving a Module Configuration to Media	22-12
Loading a Module Configuration from Media	22-13
Verifying a Module Configuration Against Media	22-13
Printing Module Configurations	22-13
Requesting a Directory of Module Configurations	22-14
RED TAGGING	22-16
Red Tag Keys	22-17
Central Red Tag Information Repository	22-17
Displaying Red Tag Status	22-17
Calling the Red Tag Status Page	22-18
Selecting a Tag or Function Block	22-18
Setting a Red Tag Key	22-19
Removing a Red Tag Key	22-20
RED TAGGING FROM OIS DISPLAY	22-21
Accessing the Red Tag Status	22-21
Dialog Box Fields	22-21
Dialog Box Buttons	22-24
Setting a Red Tag Key	22-24
Removing a Red Tag Key	22-25
Calling the Red Tag Notice Summary	22-27
Modifying Summary Options	22-27
Generating a Summary	22-29
<hr/>	
APPENDIX A - AUXILIARY ENGINEERING KEYBOARD	A-1
KEYBOARD	A-1
<hr/>	
APPENDIX B - ERROR MESSAGES	B-1
INTRODUCTION	B-1
ERROR MESSAGES	B-1
<hr/>	

List of Tables

<i>No.</i>	<i>Title</i>	<i>Page</i>
1-1.	Glossary of Terms and Abbreviations	1-12
1-2.	Reference Documents	1-14
3-1.	Display Control Block Keys	3-3
3-2.	Alphabetic Character Block Keys	3-6
3-3.	Numeric Keypad Block Keys	3-7
3-4.	Cursor and Trend Control Block Keys	3-7
3-5.	Station and Remote Control Block Keys	3-9
3-6.	Alarm Acknowledge and Silence Block Keys	3-11
4-1.	Display and Symbol File Listing	4-1
4-2.	Default Color Scheme	4-9
6-1.	Window Control Menu	6-6
7-1.	Cursor Tabbing Keys	7-4
8-1.	Color Swap Examples	8-14
8-2.	Touch Screen Serial Port 1 (Setup)	8-21
8-3.	Touch Screen Serial Port 1 (Input Extension)	8-21
9-1.	Control Tags	9-2
9-2.	Control Inhibit Indications (Control Tags)	9-4
9-3.	Station Modes	9-8
9-4.	Tracking Indicators	9-9
9-5.	RMCB Feedback Signal to Feedback Indicator Relationship	9-25
10-1.	Data Acquisition Tags	10-2
10-2.	Control Inhibit Indications (Data Acquisition Tags)	10-4
10-3.	DANG Element Next High and Next Low Alarm Limit Criteria	10-14
10-4.	TEXTSTR Element Operating Conditions	10-24
12-1.	Alarm Status Descriptors (Two Character)	12-5
12-2.	Alarm Status Descriptors (Single Character)	12-5
12-3.	Quality Indicators	12-6
12-4.	Alarm Priority Text Descriptors	12-9
13-1.	Custom Query Options	13-21
14-1.	Trend Data Error Messages	14-5
14-2.	Variable Type Descriptors (Trends)	14-5
16-1.	Control or Data Acquisition Element Source Files	16-9
16-2.	Trend Element Source Files	16-12
16-3.	Alarm Summary Entries	16-16
18-1.	Display Log - Events Retrieval Page Fields	18-13
19-1.	Archiving Nonrecoverable Error Codes	19-25
19-2.	Events Retrieval Page Fields	19-32
19-3.	Log Image Retrieval Page Fields	19-34
19-4.	Tag Data Retrieval Page Fields	19-35
19-5.	Trend Data Retrieval Page Fields	19-38
19-6.	PCU Configurations Retrieval Page Fields	19-41
20-1.	Console Clock Accuracy Ratings	20-2
20-2.	INFI-NET Time Set Example (Site Synchronization)	20-8
20-3.	INFI-NET Time Set Example (GMT Synchronization)	20-9
21-1.	Node Type Descriptors	21-4
21-2.	Module Type Descriptors	21-7
21-3.	Enhanced Module Type Descriptors	21-8
21-4.	Module Status Bytes	21-11
21-5.	Module Revision Level Availability	21-15
22-1.	Loop, PCU, Module, and Block Address	22-3
22-2.	Red Tag Capable Tag Types	22-16
22-3.	Red Tag Information Repository Query Times	22-29

List of Figures

<i>No.</i>	<i>Title</i>	<i>Page</i>
1-1.	Operator Interface Station	1-2
2-1.	INFI 90 OPEN Communication Highway and Nodes	2-2
3-1.	Operator Keyboard	3-2
3-2.	Keyboard Sections	3-3
4-1.	Common Display Characteristics	4-4
4-2.	Example Display	4-5
5-1.	General Functions Menu	5-1
5-2.	Menu Structure - General Functions Menu	5-2
5-3.	Menu Structure - OIS Configuration (1 of 2)	5-3
5-4.	Menu Structure - OIS Configuration (2 of 2)	5-4
5-5.	Menu Structure - OIS Utilities (1 of 3)	5-5
5-6.	Menu Structure - OIS Utilities (2 of 3)	5-6
5-7.	Menu Structure - OIS Utilities (3 of 3)	5-7
5-8.	Miscellaneous Menu	5-8
6-1.	Window Overview	6-3
8-1.	Standard Display Touch Pad (Small Key Size)	8-23
8-2.	Standard Numeric Touch Pad	8-23
8-3.	Standard Control Touch Pad	8-24
8-4.	Operator Keyboard Touch Pad	8-24
9-1.	Standard Process Control Faceplate Symbols	9-3
9-2.	Control Station Element	9-6
9-3.	Remote Control Memory Element	9-13
9-4.	Remote Manual Set Constant Element	9-16
9-5.	Device Driver Element	9-18
9-6.	Multi-State Device Driver Element	9-21
9-7.	Remote Motor Control Block Element	9-24
10-1.	Standard Data Acquisition Faceplate Symbols	10-3
10-2.	Analog Element	10-6
10-3.	Analog Annunciator Element	10-6
10-4.	Analog Control Element	10-7
10-5.	Digital Element	10-9
10-6.	Digital Annunciator Element	10-9
10-7.	Digital Control Element	10-9
10-8.	Data Acquisition Analog Element	10-12
10-9.	Data Acquisition Digital Element	10-17
10-10.	Text String Element	10-21
11-1.	Block Details Display	11-2
11-2.	Tuning Display	11-6
12-1.	Alarm Summary Display	12-17
12-2.	Alarm Group Inhibit Page	12-20
13-1.	Operating Parameters Page	13-2
13-2.	Tag Summaries Menu	13-15
13-3.	Example Tag Summary	13-19
13-4.	Example Tag Summary Printout	13-20
13-5.	Custom Query Window	13-21
13-6.	Tag List to Printer Page	13-23
14-1.	Trend Display	14-2
14-2.	Trend Attributes	14-4
14-3.	Trend Display - Panning Enabled	14-9
14-4.	Trend Display - Zooming Enabled	14-11
14-5.	Trend Display - Magnifying Glass Enabled	14-12
14-6.	Operator Trend Assignments Page	14-15

List of Figures (continued)

<i>No.</i>	<i>Title</i>	<i>Page</i>
14-7.	Operator Assignable Trend Assignments Window	14-18
14-8.	Operator Assignable Trend Detail	14-20
14-9.	Trend List to Printer Page	14-24
15-1.	XY Plot Display	15-2
15-2.	XY Plot Attributes	15-3
16-1.	Example Operator Configurable Display	16-2
16-2.	Example Display Setup	16-2
16-3.	Operator Configurable Displays - Directory Page	16-4
16-4.	Operator Configurable Displays - Edit Page	16-5
16-5.	Tag Elements (Page 1)	16-10
16-6.	Tag Elements (Page 2)	16-10
16-7.	Trend Elements	16-13
16-8.	Alarm Summary Elements	16-16
17-1.	Operator Action Request Page	17-2
17-2.	Operator Information Events Page	17-5
18-1.	Event Log Display - Real-Time Mode	18-10
18-2.	Event Log Display - Snapshot Mode	18-11
18-3.	Event Log Display - Search Criteria	18-13
18-4.	Log Status Menu	18-15
18-5.	Log Status Display - Custom Logs	18-17
18-6.	Log Status Display - SOE Logs	18-18
19-1.	Data Type to Volume Definition	19-7
19-2.	Volume to Media Definition	19-10
19-3.	Miscellaneous Definitions.....	19-14
19-4.	Historian Group Configuration	19-18
19-5.	Store Data Menu	19-23
19-6.	Use New Volume Menu	19-24
19-7.	Directory of Archive Volume Menu	19-27
19-8.	Example Archive Volume Directory Page	19-28
19-9.	Retrieve Data Menu.....	19-29
19-10.	Retrieve Events Page	19-32
19-11.	Print Log Images Page	19-33
19-12.	Retrieve Tag Data Page	19-35
19-13.	Retrieve Trend Data Page	19-36
19-14.	Unused Archive Trend Indices Page	19-40
19-15.	Retrieve PCU Configurations Page	19-41
19-16.	Directory of Retrieved Data Menu	19-42
19-17.	Directory of Retrieved Tags Page	19-43
19-18.	Directory of Retrieved Trends Page	19-44
19-19.	Directory of Retrieved PCU Configurations Page.....	19-45
19-20.	Tag Historian Main Menu	19-47
19-21.	Tag Historian Retrieval Menu	19-49
19-22.	Retrieve by Alarm Group Page	19-50
19-23.	Retrieve by Historian Group Page	19-51
19-24.	Retrieve by Tag Wild Card Page	19-52
19-25.	Retrieve by Individual Tags Page	19-53
19-26.	Print/Delete RDF Page	19-57
19-27.	Print RDF Tag Data Options Page	19-58
19-28.	Example Retrieved Tag Data Printout	19-59
20-1.	Set Date and Time Page	20-5
20-2.	Directory of Queued Prints Page	20-13
21-1.	System Status Overview Page	21-3

List of Figures (continued)

<i>No.</i>	<i>Title</i>	<i>Page</i>
21-2.	Node Status Summary Page	21-6
21-3.	Module Status Summary Page	21-10
21-4.	Module Firmware Revision Display	21-14
21-5.	INFI-NET Diagnostics Menu	21-19
21-6.	INFI-NET Diagnostics - Loop Topology Page	21-22
21-7.	INFI-NET Diagnostics - Node Topology Page	21-24
21-8.	INFI-NET Diagnostics - Communication Module Details Page	21-26
21-9.	INFI-NET Diagnostics - Event and Error Counters Page	21-27
21-10.	INFI-NET Diagnostics - Exception Statistics Page	21-28
22-1.	PCU Configuration Menu	22-2
22-2.	Module Configuration Menu	22-3
22-3.	PCU Management Menu	22-9
22-4.	Select Loop/PCU/Modules/Media.....	22-11
22-5.	Display Directory of Configurations	22-15
22-6.	Red Tag Status	22-18
22-7.	Red Tag Status Dialog Box.....	22-22
22-8.	Red Tag Notice Summary Display	22-27
A-1.	Key Mapping for the Auxiliary Engineering Keyboard	A-1

Trademarks and Registrations

Registrations and trademarks used in this document include:

™ @aGlance/IT	Trademark of Intuitive Technology Corporation
™ Alpha	Trademark of Digital Equipment Corporation
™ DEC	Trademark of Digital Equipment Corporation
™ DECnet	Trademark of Digital Equipment Corporation
™ DECstation	Trademark of Digital Equipment Corporation
™ DECwindows	Trademark of Digital Equipment Corporation
™ MOTIF	Trademark of Open Software Foundation
™ OpenVMS	Trademark of Digital Equipment Corporation
™ X Window System	Trademark of Massachusetts Institute of Technology
® INFI 90 OPEN	Registered trademark of Elsasg Bailey Process Automation
® INFI-NET	Registered trademark of Elsasg Bailey Process Automation
® Network 90	Registered trademark of Elsasg Bailey Process Automation
® TEKTRONIX	Registered trademark of Tektronix, Incorporated

SECTION 1 - INTRODUCTION

OVERVIEW

This instruction contains information and instructions necessary to operate an 40 Series Signature Operator Interface Station or 40 Series Operator Interface Station after configuration. The operator interface station (OIS) provides integrated operations interface, data acquisition, and reporting capability in addition to process control for the INFI 90 OPEN Strategic Enterprise Management System. Refer to the **Configuration** instruction for configuration information.

The console allows total process monitoring and control from a single control point. Flexible, dynamic, interactive color graphics displays quickly and effectively communicate equipment status and process state. By using these displays and the keyboard, control can be performed and data can be acquired from process devices distributed throughout the entire process. The displays also provide a consistent means to interpret process status and a consistent method to respond to unusual conditions (alarms).

From a software standpoint, the 40 Series Signature Console and 40 Series Console are the same. The only major difference is that the 40 Series Signature Console does not have a TUNE/CONFIG key lock. The key lock status is handled through passwords.

CONSOLE TYPES

The terms main console and auxiliary console are general terms used throughout this instruction to refer to certain types of consoles:

Main Console	IIOIS42, IS42, IS43, IIOIS431, IIOIS432, or IIOIS433 console; an IIOIS43A or IIOIS43D driver cabinet is also a main console, but it requires an auxiliary console for interface.
Auxiliary Console	IIOIC411, IIOIC4121, IIOIC4122, IIOIC4123, IIOIC413, IIOIC414, or IIOIC42 console.

The same process operations can be performed on both main consoles (OIS) and auxiliary consoles (OIC).

INTENDED USER

This instruction can be used as a guide for operators. This instruction is **not** a tutorial for process control and assumes the reader has a general knowledge of graphics-based process

control systems. It explains console interaction with the INFI 90 OPEN system only.

This instruction assumes the reader is familiar with X™ windows using MOTIF™ style windows and window manager.

DESCRIPTION

NOTE: This section discusses the primary components of a main console only. Most components and their locations are the same for an auxiliary console.

The console uses a DECstation™ along with a multibus architecture to allow flexibility and expandability. Figure 1-1 shows the console (IIOIS431) and its primary components. The IS43 console has the same primary components but their locations are different. Several hardware options can be added to the standard console package to enhance operation. Refer to the **Hardware** instruction for a detailed description and a complete list of hardware options.

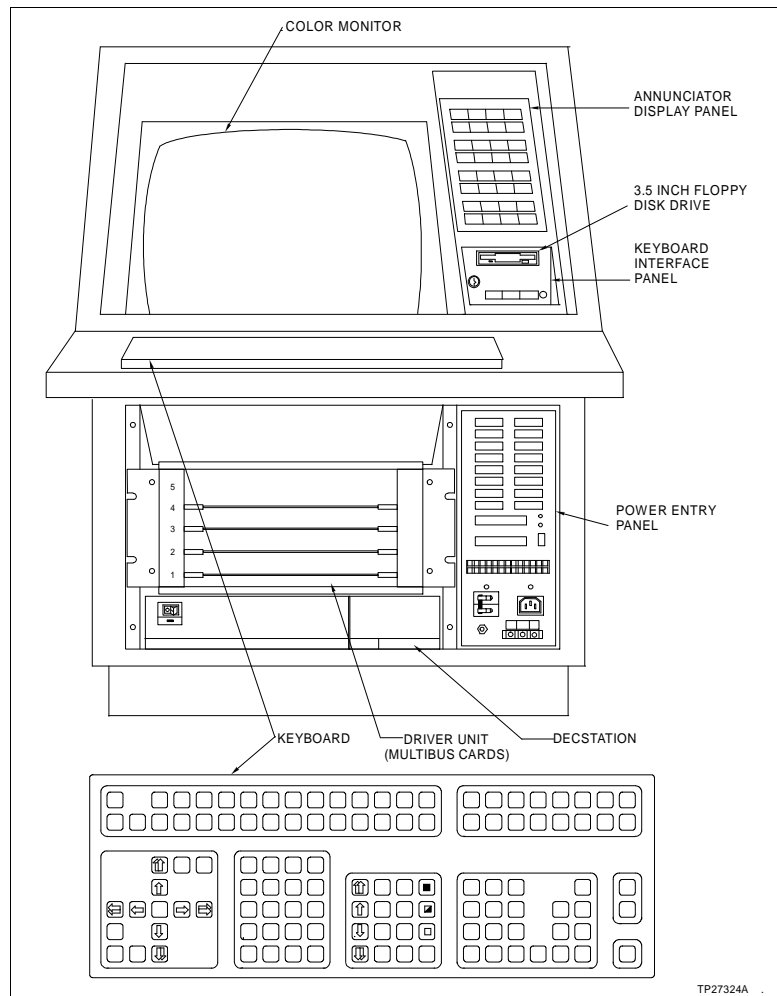

Figure 1-1. Operator Interface Station

The primary console components are:

- DECstation (main console).
- Driver unit.
- Color monitor.
- Keyboard interface panel.
- Keyboard.
- Annunciator display panel (ADP).
- Disk drives.
- Power entry panel.

This section describes the primary console components. It is important to become familiar with their locations and functions before operating the console.

DECstation

A DECstation using the OpenVMS™ Alpha™ operating system performs all processing for the console. It is mounted in the lower section of the console as shown in Figure 1-1.

The DECstation contains a central processing unit (CPU), memory, small computer system interface (SCSI), hard disks and floppy disk drive controllers, and graphics interface cards. Driver unit multibus cards provide the interface to the INFI 90 OPEN communication highway and keyboards for the DECstation. The station can directly connect to a DECnet™ network to access networking capabilities. Additionally, it can send and receive windows using either DECnet or TCP/IP transport protocol.

Driver Unit

The driver unit hardware connects and interfaces the console to the communication highway. These modules also execute programs controlling console operation and communicate with the monitors, keyboards, printers, and other supported peripherals. The ability to communicate on the loop and with its peripherals gives the console access to the entire plant system and supported devices through interactive and dynamic displays.

The driver unit modular circuitry mounts in a multibus card cage located at the front, lower section of the console. An access door covers and protects this circuitry during normal operation. The multibus card cage provides the communication path and hardware priority level for the multibus modules, which include:

IIMCLO1 Multibus Communication Loop Termination Module - terminates communication highway coaxial or twinaxial cable.

IIMLM01 Multibus Loop Module - enables communication between the communication processor module and INFI 90 OPEN communication highway through the communication termination module.

IIMCP01 or IIMCP02 Multibus Communication Processor Module - executes the commands required to send data to and receive data from plant process control units (PCU) and other operator consoles and interfaces. The IIMCP01 module is part of a 10,000-tag interface unit to the Plant Loop system. The IIMCP02 module is part of a 30,000-tag interface unit to the INFI-NET[®] system.

NOTE: The IIMCL01, IIMLM01, and IIMCP01 or IIMCP02 modules comprise the communications interface unit of the console.

IIMKM02 Multibus Keyboard Module - interfaces the keyboards and annunciator display panels (ADP). It controls six solid state alarm output relays and five keyboard alarm tone annunciators. It also interfaces the optional touch screen through a touch controller board mounted on this circuit board.

Color Monitor

The console uses a 19-inch color monitor to display its color graphics. The screen is the primary information device. It presents a variety of displays and windows used to perform the different console functions. The console supports 64 unique colors.

Keyboard Interface Panel

The keyboard interface panel provides connection ports for the operator keyboard, auxiliary engineering keyboard, mouse or trackball, and a tabletop annunciator display panel. The TUNE/CONFIG key lock switch (40 series console only) and floppy disk drive are located at this panel.

Authorized personnel can configure and tune most PCU modules and troubleshoot the system using the keyboard. A single key lock switch protects against accidental changes or data loss from unauthorized configuration and tuning. The switch restricts certain functions to only authorized personnel.

The key lock switch is labeled as TUNE (tuning) and CONFIG (configuration). The only way to change the key lock position is to insert a key and turn. After changing the switch position, the key can be removed to lock the key switch in either the OFF, TUNE, or CONFIG position.

Password security also protects against unauthorized changes. It is defined during console configuration. Password security

can be used along with key lock protection or can disable key lock requirements.

Keyboard

The operator keyboard is a flat panel covered by an overlay with alphabetic, numeric, and specialized function keys. It connects to the KEYBOARD connector located at the keyboard interface panel. The keyboard gives access to various displays, then allows operator interaction with the displayed elements. Information for any process loop or device in the INFI 90 OPEN system can be displayed and any process loop or device can be controlled from the keyboard.

An auxiliary engineering keyboard is a typewriter-style, QWERTY keyboard that can be used along with the operator keyboard. This keyboard connects to the AUX KEYBOARD connector located at the keyboard interface panel. Refer to [Appendix A](#) for auxiliary keyboard key mapping.

Both the operator keyboard and the auxiliary engineering keyboard connect through an IIMKM02 keyboard interface. Besides connecting the keyboards, the interface also drives annunciator display panels and alarm tones and relays. Windows can be sent to other platforms besides OIS and OIC consoles. In this case, the keyboard of the terminal receiving the window does not connect through a keyboard interface. Without the keyboard interface, the terminal cannot drive annunciator display panels and alarm tones and relays.

Annunciator Display Panel

An annunciator display panel contains 32 indicator and push-button pairs. Any process point defined as a tag can be assigned an ADP lamp and each pushbutton can be assigned a display, user task, or key macro. A pushbutton can also be used to activate a multiwindow display call-up.

After being configured, a process point that goes into an alarm condition causes its assigned ADP indicator to light. The display required to view and take action on the alarm condition can then be called by pressing the associated pushbutton. A key macro assigned to an ADP pushbutton incorporates multiple keystrokes into a single key press. A user task assigned to an annunciator display panel allows immediate execution of a user-written program at any time by pressing a pushbutton.

A single console supports up to four annunciator display panels. The second is an optional tabletop type that connects at the keyboard interface panel. Any additional panels are daisy-chained from this second panel.

Disk Drives

The console has two hard disks and a floppy disk drive. The floppy disk drive handles removable 3.5-inch, high density disks. This drive can be used to transfer, save, and restore configurations files. The floppy disk drive is located at the keyboard interface panel.

One of the two hard disk drives contains the OpenVMS operating system software. The other drive provides on-line storage for:

- Console operating software.
- Assembled display files.
- Log and trend data.
- Archived data.
- Configuration data.

Power Entry Panel

The power entry panel is located behind the front access door. This panel contains:

- Main power connection point.
- Main power on/off switch.
- Power on/off indicator.
- Console reset switch.
- I/O and peripheral ports.
- Keyboard I/O terminal block.
- Degaussing switches.

Printers

Up to four different printers can be accessed for creating hard copy records of plant alarm occurrences, configured logs, and system events. Up to four additional but different printers can also be accessed for creating hard copy printouts of displays. The printers designated for logging purposes are completely independent of those used by the screen copy function.

The printer types for logging are either standard black and white, high speed black and white, or four-color dot matrix. A printer assignment for logging is set during configuration of a log.

Printer configuration and selection for the screen copy function is performed by using a printer configuration utility. Refer to **SCREEN COPY** in Section 8 for further explanation and for a list of the printers supported for screen printing.

FEATURES

30,000-Tag Capacity. Monitors and allows operator control of up to 30,000 tags through dynamic, interactive color graphics displays. The maximum number of tags is 30,000 if using an IIMCP02 module. If not, the maximum is 10,000 tags.

Eight OIS Windows. Generates up to eight windows that can be directed to the local screens of the console, to auxiliary consoles, or to other nodes connected to the network. The console can send and receive windows using DECnet or TCP/IP transport protocol.

Custom Graphics. A flexible graphics hierarchy enables the creation of displays tailored to specific application needs. Text, shapes, lines, and symbols as well as real-time dynamic value and state fields present information in status displays or process mimics. Dynamic symbols can be created to change in shape, color, and position to reflect process changes. Standard device faceplate symbols and status display templates are provided in the software.

Full Control and Input Capability. Fully supports configuration, control, and tuning of process control parameters within the INFI 90 OPEN system from both standard faceplates and user-designed graphics.

10,000-Point Distributed Trending. Provides for distributed trending of up to 10,000 variables. Trending offers a historical perspective of process conditions for analysis of operations.

Logging. Creates up to 300 custom logs (standard, trip, or periodic type), 160 sequence of events (SOE) logs, an event log containing up to 1,000 events, and up to 12 alarm summary reports. These logs provide a hard copy history of process operations and customized operations summaries.

Advanced Alarm Management. Multilevel alarming capabilities optimize response through color coded prioritization and single keystroke alarm acknowledgment.

Single Action Display Access. Display or control selects can be performed with a single operator action using the keyboard, a touch point, or an annunciator display panel.

High Resolution Monitor. Supports 1280 × 1024 resolution monitors.

Historical Data Archiving. Archival functions provide a history of process operations for subsequent analysis and process improvement. Archived data can include tag, trend, log, system events, and PCU configuration data. The console supports archiving of all data types to magnetic tape and optical disk. It

also supports archiving of logs and events to an open access system (OAS).

NOTE: Magnetic tape refers to digital audio tape. This console does not support nine-track magnetic tape.

System Troubleshooting and Diagnostics. Enables on-line system troubleshooting and diagnostics through system status displays and INFI-NET diagnostics functions.

System Tuning and Configuration. Allows module configuration and tuning capabilities over the INFI-NET and Plant Loop communication highways.

INSTRUCTION CONTENT

This instruction contains information necessary to operate the console after it has been configured. It includes a Table of Contents, List of Figures, List of Tables, and Index giving several options to locate specific information quickly. Appendices supplement information presented in the individual sections.

This instruction explains operation referenced to standard operational displays provided with the console. Flexibility in display creation allows tailoring these displays or creating user-defined displays designed to meet specific requirements of any given plant. All operational capabilities remain the same whether using standard or user-created operational displays.

The description and functions part of the instruction is intended to familiarize the reader with console functions and operating theory and with the components that provide an interface to these functions. A general understanding of the console is necessary to insure optimum use of all available features and functions. The sections that make up this part of the instruction include:

Introduction Describes the content of this instruction and its intended user. It also highlights some console features.

System and console overview Introduces the console describing its function in the INFI 90 OPEN system.

Keyboard and peripherals Describes the keyboard and peripheral devices that enable interaction with the console.

Display system Gives an explanation of the display system including fixed screen elements and user-created elements.

Menu structure Gives a tree structured view of the configuration, utility, and operation menus. Provides a quick reference when accessing functions from menu selections.

Windows system	<p>Describes the console windows system and includes a description of the IIOIC41 and IIOIC42 auxiliary console operation. An auxiliary console receives its OIS window from a main console.</p> <p>The remainder of the instruction explains specific operations. It describes operator actions that can be taken to monitor and control a process, explains console and system operations, and explains how to record process data. The operations discussed can be performed after all display creation and console configuration have been completed. The sections that make up this part of the instruction include:</p>
General operations	<p>Describes the steps required to begin operating the console including start-up and password log-in. It also discusses the different methods of accessing operational displays and the different methods of selecting displays and display elements for control.</p>
Windows applications and utilities	<p>Describes the message window and log-in window applications and the screen copy, touch screen, and touch pad configuration utilities.</p>
Process control	<p>Details the information presented in standard faceplate elements designed to mimic process devices and the control operations performed by using these elements. The same information presented and capabilities available in standard control elements can be incorporated into any user-created display.</p>
Data acquisition	<p>Details the information presented in standard data acquisition faceplate elements and the control operations performed by using these elements. The same information presented in standard data acquisition elements can be incorporated into any user-created display.</p>
Tuning and block details	<p>Explains the process tuning functions available on the console. It also details tuning display and block details display operation.</p>
Alarm management	<p>Explains alarm indications, the procedures to process alarms, and the procedures to manually inhibit alarm indications. It also details the information and functions performed with an alarm summary display or element.</p>
Tag operations	<p>Explains the functions used to view the operating parameters of tags, to view and print a summary listing showing the current status for tags, and to print a tag database listing.</p>
Trend operations	<p>Explains the information seen in trend displays and explains trend control. It also gives the procedures to create operator assignable trends and to print a listing of trend definitions.</p>
XY plot operations	<p>Explains the information seen in XY plot displays and plot control.</p>

Operator configurable displays	Gives the procedures to create an operator configurable display. This type of display can be created from the console rather than having to use the console configuration tools (WLDG) program. The display is not a permanent display and can be modified or deleted at any time.
Operator actions and information	Describes the pages used to monitor certain functions. The pages indicate the current operation being performed and any operator actions required to continue processing of indicated operations.
Logs	Describes the logging functions. These capabilities allow recording process and console related data as a hard copy printed log.
Archive data	Describes the archiving functions. These capabilities allow recording process and console related data digitally on an archive medium.
Utilities	Explains how to set the date and time for the system and the local time for the console. It also explains how to cancel queued prints.
System diagnostics	Describes the pages that present system status.
System management	Explains the system configuration utilities available on the console. These utilities can be used to configure, save, verify, load, and view module configurations. It also explains red tag status operations.

HOW TO USE THIS INSTRUCTION

Besides operation information, this instruction also provides information about those configurations performed outside the OIS application such as touch pad, touch screen, and screen copy printer configuration. These are windows applications. Refer to the **Configuration** instruction for information on OIS application configuration.

To attain optimum use of all available features and functions, it is important to become familiar with the entire contents of the instruction before operating the console. To use the instruction:

1. Read **Section 2** for an overview of the system and console functions.
2. Read **Section 3** through **Section 5** to become familiar with the keyboards, annunciator display panels, display system, and menu structure.
3. Read **Section 6** for a description of window operations specific to the OIS application running on the console.

4. Read **Section 7** for a description of general console operations. This section begins with the steps to start-up the OIS application, describes the key lock and its function, and gives steps to login a password (password for the OIS application). It then describes data input, methods to access displays, and methods to activate a display or display element for interaction.
5. Refer to the **Configuration** instruction for console configuration requirements and procedures.
6. Read **Section 8** for information about windows applications and utilities that run on the console such as the message window and log-in window applications, and the screen copy, touch screen, and touch pad utilities.
7. Read the remaining sections as needed. For example, to find information about operator configurable displays, read **Section 16**.
8. Read the Appendices for information on the auxiliary keyboard and error codes. Refer to the **Configuration** instruction for task codes.

Hint To find information on a specific option, refer to the index. All options described in this instruction appear under the heading **Option**. Not all options are described in this instruction. Refer to the **Configuration** instruction for options not listed.

Read the **notes** in text. Notes provide:

- Additional information.
- Information that should be considered before performing a certain operation or function.

DOCUMENT CONVENTIONS

NOTE: The OIS application is case sensitive. For example, entering **tagname** will not call the tag **TagName**. They are two distinct names.

This document uses standard text conventions throughout to represent keys, user data inputs, and display items:

KEY Identifies a keyboard key.

Example: Press **ENTER**.

USER INPUT Indicates a fixed input that must be entered exactly as shown.

Example: Type **FIRMWARE**.

Display item Any item that displays on the screen appears as italic text in this document.

Example: *A OIS Configuration* (menu selection)
General Functions Menu (display title)
SELECT a Cell Item from the Menu (message)
Tag name or index number (prompt)

File name Any file names and file extensions appear as bold-italic text.

Example: ***DISPL1.DU***
DT

GLOSSARY OF TERMS AND ABBREVIATIONS

Table 1-1 is a glossary of terms and abbreviations used in the instruction. It contains those terms and abbreviations that are unique to Elsasg Bailey or have a definition that is different from standard industry usage.

Table 1-1. Glossary of Terms and Abbreviations

Term	Definition
Cascade Station	An analog control station configuration that allows an externally generated signal, such as the output of an upstream controller, to control the set point. One of three station types available in the normal operating mode.
Control Module	Directs field processes through an I/O module; the multi-function processor is an example.
Device Driver	An INFI 90/Network 90® system function code that provides control for a single input device.
Display Element	A discrete element used in creating a process display; station faceplate, annunciator, trend, and deviation overview are display element examples.
Display Generator	User-interactive software for creating display screens.
EUD	Engineering unit descriptor.
EWS	Engineering work station.
Exception Report	Information update generated when the status or value of a point changes by more than a specified significant amount; abbreviated as XR.
FC	Function code.
Function Block	The occurrence of a function code at a block address of a module.
Function Code	An algorithm which manipulates specific functions. These functions are linked together to form the control strategy.
INFI-NET	Advanced data communication highway.
LSD	Logic state descriptor. A character string which is associated with the state of a digital point.
MCS	Management command system. Integrated operator console with data acquisition and reporting capabilities. It provides digital access into the process for control and monitoring.
MFC	Multi-function controller module. A multiple loop controller with data acquisition and information processing capabilities.

Table 1-1. Glossary of Terms and Abbreviations (continued)

Term	Definition
MFP	Multi-function processor module. A multiple loop controller with data acquisition and information processing capabilities.
Module Address	A unique identifier of a specific device or a communication channel. Refers to Controlway or module bus address.
Module Bus	Peer-to-peer communication link used to transfer information between intelligent modules within a process control unit.
MSDD	Multi-state device driver; provides control for a dual input device.
NIU	Network interface unit. Term for all local and remote interfaces, computer interfaces and console interfaces to the INFI-NET communication system.
Node	A point of interconnection to a network.
Node Address	A unique identifier of a specific device or a communication channel. Refers to Plant Loop or INFI-NET address.
Not-Set-Permissive	A remote switch input to a remote control memory function block that disables remote switch set commands.
OIS	Operator interface station. Integrated operator console with data acquisition and reporting capabilities. It provides a digital access into the process for flexible control and monitoring.
Override	A remote switch input to a remote control memory function block that controls the block output under certain conditions.
Peer-to-Peer	Refers to the communication between different modules at the same communication hierarchical level within an INFI 90 system.
Plant Loop	Network 90 data communication highway.
Primary Module	Active module in a redundant configuration.
Problem Report	A summary of error conditions provided by INFI 90 modules.
Ratio Index	An analog input to a station function block.
Ratio Station	An analog control station configuration that maintains a ratio between two variables. The ratio of an externally generated wild variable times the controlled variable becomes the set point that provides regulation of a third variable. One of three station types available in the normal operating mode.
Red Tag	A logical flag that indicates a point is out of service.
Remote Control Memory Report	A computer interface point type that allows the host computer to simulate remote control memory function code configured in the computer interface.
RMSC	Remote manual set constant; a function code which generates exception reports consisting of a status and an analog value.
Secondary Module	Backup module in a redundant configuration.
Specifications	Function block input values that determine function block characteristics.
Static Element	The background graphics and text of a display. These display elements do not change as the process changes.
Symbol	A drawing element. Using symbols for commonly used drawing elements eliminates redrawing.
Tag	An analog or digital process value defined in the console or PCV as a control or monitor point.
Time Stamp	A value representing the absolute INFI 90 system time.
Time Sync	A mechanism for synchronizing parts of an INFI 90 system to a common clock.

REFERENCE DOCUMENTS

This instruction provides operation information only for the console. Table 1-2 lists additional documents that relate to operation and are referenced in this instruction.

Table 1-2. Reference Documents

Number	Document Title
I-E96-200	Function Code Application Manual
I-E96-754	User Task Interface
I-E96-771	Console Configuration Tools (WLDG)
I-E96-825	Software Global Database Manager (SGDM)
WBPEEU1220757A1	Configuration (40 Series)
WBPEEU1220758A1	File Utilities (40 Series)
WBPEEU1220759A1	Display Builder Reference
WBPEEU1220760A0	Hardware, Operator Interface Station (IIOIS43)
WBPEEU1220761A0	Hardware, Signature Work Station (IS42/IS43)
WBPEEU1350255A0	Open Data Server/Client
WBPEEU1350255A0	Hardware, Operator Interface Station (IIOIS42)

SECTION 2 - SYSTEM AND CONSOLE OVERVIEW

INTRODUCTION

This section introduces the operator interface station (OIS) describing its function in the INFI 90 OPEN system. It provides a brief overview of selected INFI 90 OPEN system components and explains console functions and operating theory.

INFI 90 OPEN SYSTEM OVERVIEW

The INFI 90 OPEN Strategic Enterprise Management System is a distributed process management and control system. Using a series of integrated control nodes, the system allows monitoring and control of process variables such as flow rate, temperature, and pressure according to a control configuration that the process (system) engineer or technician defines. A node is any device connected for communication on the INFI-NET or Plant Loop communication highway.

Figure 2-1 shows a single communication highway system with INFI 90 OPEN nodes. This figure presents only specific nodes that relate directly to the procedures discussed in this and the **Configuration** instruction. Depending on the type of communication highway being used, a single loop can contain up to 250 individual nodes. Additional nodes can be other consoles, process control units, and local and remote interface units.

Communication Highway

The INFI 90 OPEN system operates on either an INFI-NET or Plant Loop communication highway. The communication path established by the highway ties each system node together for:

- Sharing control variables among modules in different nodes.
- Monitoring operation of control configurations in control nodes.
- Performing control from a console, or from a computer connected through a network interface unit.
- Configuring and maintaining PCU control configurations from a console or computer.
- Monitoring the status of system components from a console or computer.

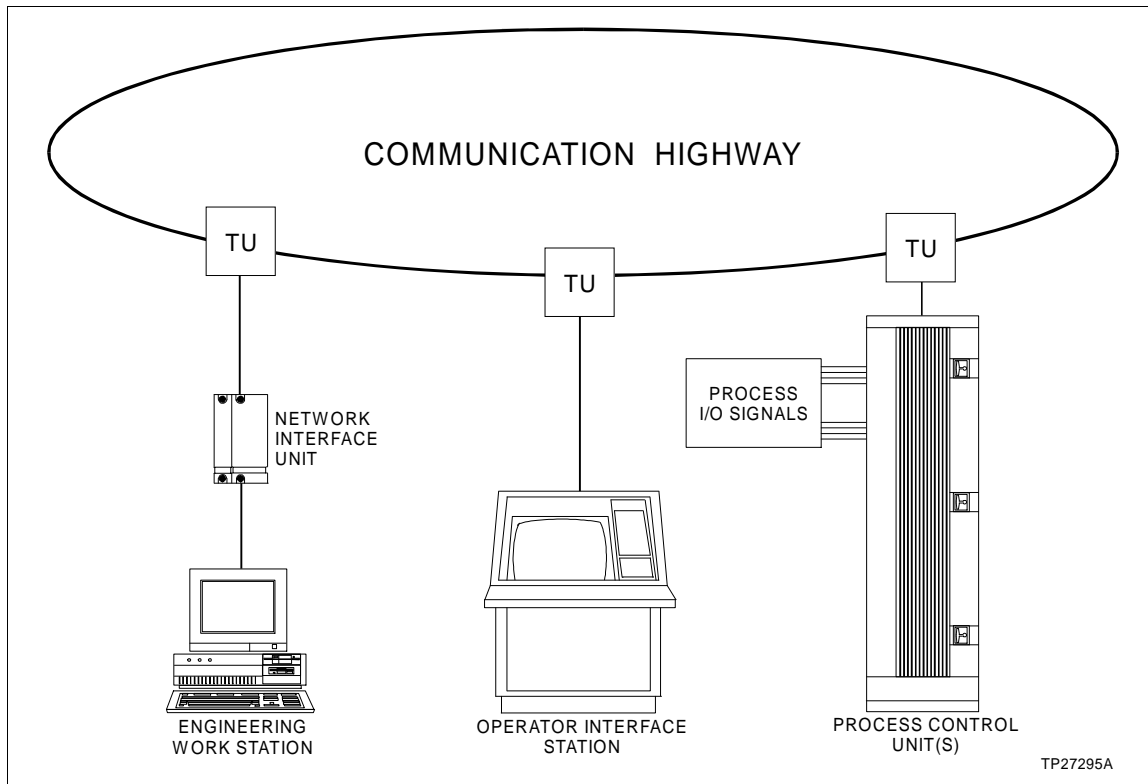

Figure 2-1. INFI 90 OPEN Communication Highway and Nodes

The INFI-NET communication highway supports up to 250 loops with up to 250 nodes per loop. The Plant Loop communication highway supports a single loop with up to 63 nodes.

Process Control Unit

The process control unit (PCU) is the fundamental control node of an INFI 90 OPEN system. The actual process control and management takes place at this level. Predefined algorithms set in memory of a PCU control module establish parameters for process control. These parameters also determine the operation of functions such as alarming, trending, logging, and process monitoring and control on a console.

PCU refers to either a group of control modules and their I/O modules or any cabinet containing:

- Power panels.
- Configurable control modules and their I/O modules.
- Termination units or modules.

A single cabinet may contain several process control units, each having their own communication interface modules, and each identified by a distinct hardware (node) address.

A PCU can be a stand-alone control system containing:

- Control stations for system interfacing. Control and indicator stations physically located on the process floor display process variables and allow process changes.
- A configuration and tuning terminal (CTT) for modifying control configurations. A CTT terminal enables local building and modifying of control configurations in PCU modules.

Individual control modules store configuration data in on-board, nonvolatile memory. A nonvolatile memory device retains data even after removing power. It is possible to back up (store) and download stored configurations from floppy disk or from the hard disk of a computer or console.

Termination units or modules directly connect process field device I/O signals to process control units in the INFI 90 OPEN system. The communication highway links all process control units together in series. This enables a process control unit in the plant to share control functions and data with any other process control unit in the system. It also lets consoles and computers communicate with any process control unit. This communication is necessary to acquire process values and to put process changes into effect.

Operator Interface Station

The console can be used to monitor and control plant operations from a single point. The number of consoles in a system varies depending on the overall control plan and size of a plant. A console enables monitoring, tuning, and control of an entire plant process from its color graphics displays and push-button keyboard. There are many other operator interface devices the console enhances such as analog control stations, analog indicator stations, and digital logic stations.

The console can be used to configure and maintain control configurations throughout the plant system. It is able to read and display any module configuration in the system. A module configuration can be modified from the console with the modifications being written to the module. A module configuration can be read then saved to the console hard disk. Additionally, a configuration can be read from the hard disk then written to a module.

For process management, process (tag) details can be listed, various alarm limits can be changed, plant control can be locked out by password, and files can be manipulated from the console. The console has on-line data recording and system diagnostics capabilities.

Network Interface Unit

Network interface unit (NIU) is a general term used to describe INFI 90 OPEN modules that provide an interface or access to the communication highway. A network interface unit is a group of modules that provide a link between separate communication highways or an interface to the loop for a console, computer system, or another network.

Figure 2-1 shows an interface unit connecting an engineering work station (i.e., computer) to the loop. For computer interfacing, the interface unit is either an INFI-NET to computer interface (ICI) or Plant Loop to computer interface (PCI) depending on the communication highway. Although not shown in this figure, the console also has a dedicated communications interface unit consisting of multibus modules.

Through a network interface unit, a computer or console has access to any node on the loop. This connection allows gathering process information, making process decisions, and performing or recommending process changes. The interface unit does not directly display any information. It requires a console or computer for display of information.

An interface unit is an automatically operating device. A computer or console performs process monitoring and control based on internal calculations and program routines set in the interface unit. The interface unit also serves as a data acquisition point for the host computer or console. The console downloads its database information during start-up to establish the operations of its own interface unit.

The network interface unit is programmable during configuration, but it is not used directly by the operator to interface with the system. Process data is collected and operator control actions are implemented through the interface unit by the console.

Engineering Work Station

An engineering work station (EWS) supports database management and display creation for the console. It also provides additional utilities and engineering tools used in INFI 90 OPEN management. Some tools available for use on an EWS computer include:

- Console configuration tools (WLDG).
- Module configuration tools (WCAD).
- Global database manager (SGDM).

FUNCTIONS

INFI 90 OPEN control modules perform the actual process control by implementing a control configuration loaded in module memory. The control configuration is made up of function codes combined in various configurations downloaded to the PCU module. A function code is a software algorithm that defines a calculation, function, or I/O for the module. A set of function codes arranged in a logical order define module control responsibilities. These function codes also determine and are related to all console operations.

The console enhances the INFI 90 OPEN system and PCU modules by providing a single point for:

- Managing and configuring process control configurations throughout the entire plant. A control configuration can be created and modified from the console.
- Processing alarms. Reports, point values, and alarms are received in exception report messages from PCU modules.
- Making control changes. Operator actions that initiate process control can be performed from the console.
- Tuning. Control configuration specifications can be fine tuned from the console.

Operations Interface

As an interface to the process, the console supports monitoring and control with its graphic displays. These displays quickly and effectively communicate equipment status and process state. The displays also provide a consistent means to interpret process status and a consistent method to respond to unusual conditions (alarms).

A process display is configured within the display area with any of 64 available colors. Each display can incorporate dynamic variables, dynamic symbols, and static elements allowing a considerable amount of information to be condensed into a single display. Graphic elements for process dynamic data and graphic elements for static data can be combined with predefined or user-created symbols to form a complete display. This allows setting up detailed process schematics, faceplates, and summary displays for monitoring and control.

The console does not have a fixed display hierarchy for user-created displays. Displays can be created as desired to support different processes and applications. The logical connections between displays can be set up as desired.

The operator keyboard is the primary operator interface to the console and the process. Optional devices such as annunciator display panels and touch screen can be added to enhance operation.

Security Management

Security features prevent unauthorized access to console functions. Key lock and password security can be used to limit access to process displays, variables, control points, and configurations, and to console configurations and utilities. Password security can be tailored to plant needs. Security can be set up to accommodate individual personnel's responsibilities and the types of operations they are to perform.

Passwords control access to functions at a higher level than key lock by defining access rights for individual users. Each password defines configuration, control, tuning, monitor, alarm management, log operations, and window access rights. Personnel must log into the console with the appropriate password after password security has been defined.

Database

The tag database is the foundation for all console functions. Each tag in the database enables communication with a point in the process. The database includes specific information for each process variable that is to be controlled and for each process variable that is to be displayed, monitored, trended, logged, and archived. The database can be created or modified by using console functions or the console configuration tools.

The trend database defines variables used in trending functions. These definitions allow data to be retrieved from the INFI 90 OPEN distributed trending system. This database includes specific information required for proper display, logging, and archiving of historical, trended data.

Database Summaries Specific attributes in the tag and trend lists can be searched for to compile printed database listings. For example, all tags with hardware addresses in a specific process control unit could be listed in order of their module and block address.

Tag Status Summaries Displayed or printed listings of all tags with a specific operating status can be compiled. Tag summaries can include all tags or only tags with:

- Alarms.
- Acknowledged alarms.
- Bad quality.
- Manually inhibited alarms.
- Manually substituted values.
- Off-scan status.

- Red tag status.
- Suppressed status.
- Suspect quality.
- Unacknowledged alarms.

Alarm Management

Alarm limits defined in control configurations are monitored by the console to notify of abnormal conditions. Extensive alarm management capabilities allow quick response to these conditions. Alarm management sets up standard indications that help to insure proper response to process alarms and to minimize nuisance alarms.

Acknowledgment

Any display can be created to contain an alarm status field. This field is associated with a process value or state on the display. When an alarm occurs, the field changes to identify the type or level of alarm. Keyboard actions must be performed to acknowledge the alarm. This acknowledgment is the first step in alarm processing. An acknowledgment stops alarm indications that notify of an alarm such as a flashing alarm group indicator, a flashing alarm status/quality/group field, a flashing dynamic symbol, and an alarm tone.

Alarm acknowledgment can be sent over the communication highway to acknowledge an alarm on other consoles. Acknowledgment can also be defined to automatically occur based on the condition of another process variable (tag).

Alarm Comments

An alarm comment field of up to 64 characters provides additional information for process alarms. An alarm comment can be defined for each alarm level or the alarm state of a process variable. The comment can describe, for example, the purpose of the alarm or any operator actions that should be taken to correct the alarm. Any display can be created to present alarm comments for a tag.

Alarm Groups

Each process tag in the database can be assigned to any one of 99 alarm groups. This allows arranging an area of related process points into a group for easier management. When an alarm condition exists for a process point, its alarm group number appears at the top, right corner of the window by default. The group number continues to flash until all alarms within the alarm group are acknowledged.

Each group can have a distinct alarm tone and a specific external alarm relay assigned. The alarm tone provides an audible indication. The alarm relay can be used to trigger an external alarm annunciator. Alarm tones and relays can be triggered by alarm group or by alarm priority but not both.

Alarm Inhibiting

An alarm inhibit option can be used to manually turn off alarm indications for individual tags or an entire alarm group. An

alarm tone does not sound, an alarm relay does not trigger, and acknowledgment is not required for inhibited tags. Inhibited tags are not added to the alarm summary and event log.

Automatic alarm inhibiting can also be set up to trigger inhibiting based on a specific process condition. The process condition can be an alarm level or the alarm state of another process variable, or the digital state of a process point.

Alarm Priorities

Alarms can be sorted by priority. There are eight priority levels for alarms. Each tag type has a variable number of alarm conditions associated with it. Priority can be assigned to each tag alarm level or the alarm state and to the return-to-normal condition. Also bad quality, when used to trigger alarming, can be given a priority. Descriptive text is associated with each priority level for easier recognition. Alarm priority indicators can be enabled to indicate the existence of alarms with certain priority levels.

Each priority can have a distinct alarm tone and a specific external alarm relay assigned. The alarm tone provides an audible indication. The alarm relay can be used to trigger an external alarm annunciator. Alarm tones and relays can be triggered by alarm priority or by alarm group but not both.

Alarm Summary Display

An alarm summary display lists alarms for all or specific process variables depending on its configuration. A time of occurrence is given for each alarm. The entries in this summary appear arranged chronologically or by priority level. A summary can contain up to 1,000 most recent alarms. The total number of current outstanding alarms and the number of those that are unacknowledged is given in this display.

Alarm summaries can be filtered. A given alarm summary can contain all alarms, unacknowledged alarms only, or acknowledged alarms only. Besides the types of alarms, the alarm summary can be limited to certain alarm groups or alarm priorities. A summary can list alarms for all or only specific alarm groups or for all or only specific alarm priorities.

Single key access to a primary display for any alarming point listed in the alarm summary is a standard feature. The primary display is normally the display used to initiate actions to correct the alarm.

Alarm Summary Report

The alarm summary report provides a snapshot printout of alarms currently being saved for alarm summaries. The printout is similar in appearance to the alarm summary display. Alarm summary reports can be scheduled to print periodically or after being triggered by a process event.

**Multilevel, Deviation,
and Rate Alarming**

The INFI 90 OPEN system provides support for distributed data acquisition functions which enable multilevel, deviation, and rate alarming for process variables. The alarming is a

function of the control configuration in a PCU module. Specific indications are given by the console for alarms based on alarm level, high or low deviation, or high or low rate of change. The indication identifies each alarm level as the process variable reaches a set alarm threshold.

Variable Alarm Limits Alarm limits can be configured to track automatically based on specific process changes. The multilevel alarming capability still applies and thresholds adjust according to a process variable being tracked.

Process Trending

Trending on the console offers a historical perspective of process conditions for analysis of current operations. Trend data can be displayed referenced to time or as a function of other process variables. The data can also be printed.

TREND DISPLAY

Both standard and custom trend display capabilities are provided. Standard trend displays come in a number of set sizes, whereas, the custom trend displays can be set to any desirable size so long as it is not larger than the allowable maximum display size. Both types of trend displays can support up to five trended variables with changeable display range, time span, and resolution. Several functions inherent to trend displays allow moving, expanding, shrinking, and magnifying the display. Any changes affect the display only and remain in effect only until exiting the display.

Magnify A magnifying glass function expands the time scale for a portion of the trend display to determine the exact time a process event or disturbance occurred.

Modify Range The high and low scale limits can be changed for each trend line displayed. The current data segment and any other data that the time cursor is moved to uses these scale ranges.

Move Time Cursor When the time cursor is activated and moved along the trend line, the system digitally displays the historical value indicated by the time cursor position.

Pan A pan function shifts the display back in time to show historical process variables.

Zoom The zoom function expands or compresses the time span of the element for easier trend analysis.

XY GRAPH

Trended values can be displayed in an XY graph. This type of display can be set up to compare up to five process variables to

a sixth or to display five pairs of variables whose x-coordinate position is determined by one process variable and y-coordinate position by another.

OPERATOR ASSIGNABLE

Operator assignable trends allow trending of the process values for any tags in the tag database or the output of any function blocks in a PCU module that are not defined as tags. This function is separate from trends defined in the trend database. Up to 20 operator assignable trends can be configured to help analyze specific process events. These trends are updated at two-second intervals and up to two hours of data is stored.

Logging

Console logging functions can be used to produce process summaries periodically or to record process events as they occur. Extensive logging capabilities are provided to create custom, sequence of events, system events, and alarm summary reports. Refer to **Alarm Management** in this section for a description of an alarm summary report.

CUSTOM LOGS

Custom logging capabilities create spreadsheet format summaries of three types: periodic, system event triggered, and operator demanded. The periodic log produces operations summaries hourly, daily, weekly, or yearly. The event triggered log produces summaries of a particular operation (e.g., batch report, pre-fault, and post fault log). The operator demanded log is an unscheduled log.

A defined time, a selected process event, or an operator demand triggers data collection and printing for each report. Printing can also be setup to automatically occur after the log completes a scheduled collection period. Up to nine most recent generations of each configured log can be saved. Some standard custom logs include trend, trip, and snapshot logs.

- | | |
|---------------------|--|
| Snapshot Log | A snapshot log collects and prints the current values for up to 250 process variables at log completion time. Snapshot logs can be process event or time triggered. |
| Trend Log | A trend log collects and prints trended data at specified intervals for up to 20 variables with up to 250 values for each. The intervals for data collection can vary. |
| Trip Log | A trip log records a history of up to 20 variables. A maximum of 250 values for each variable composed of pre-event and post event data can be included in a trip log. |

SEQUENCE OF EVENTS LOG

Sequence of events logs access data collected by an Elsag Bailey sequential events recorder (SER), sequence of events slave (FC 210) function block, or INSEM01 Sequence of Events Module. The sequence of events report generated by a recorder provides one-millisecond resolution time-tagging for critical event time of occurrence. Report types include scheduled standard, pre-fault, post fault, and snapshot reports and operator initiated summary reports.

SYSTEM EVENT LOG

The system event log provides a sequential list of process and system alarms, process events, operator actions, and operation notes. A system event log can print continuously, periodically, or on demand. Up to 1,000 most recent events can be saved for periodic printing and to archive for long-term storage.

Archival Storage and Retrieval

Trend, log, system event, PCU configuration, and tag data in any combination can be digitally stored to an archive medium. The console supports two media types: Magnetic tape and optical disk. It also allows archiving logs to an open access system (OAS).

Information Storage

Once set up, information to be archived is automatically transferred to a removable archive medium or to an open access system. The status of archival storage operations is reported with operator action and operator information messages.

Information Retrieval

Archived information is either transferred from an archive medium to the hard disk or immediately printed when a retrieval request is made. Only information within a specified time period is transferred or printed. A retrieval utility searches time-tagged archive files for data within the specified time period.

Archived system events and log data can easily be read back into the console for printing. Trend and PCU configurations can be read and stored by the console for display and PCU management respectively. Database summaries derived from archived tag database snapshots can also be printed.

System Status and Diagnostics

System and node status displays can be created to show status for devices in the INFI 90 OPEN system. Status is available for all control, data acquisition, and communication modules; consoles; and PCU power supplies in the system. Module problem reports can be accessed to diagnose faults down to module I/O level for ease of maintenance.

A set of console diagnostic functions can be accessed to facilitate the diagnosis of communications related problems. These functions provide diagnostics information on a system-wide basis. The functions help to reduce the time and effort spent diagnosing communication related faults and to minimize the need for time consuming visual inspections of nodes and modules to determine the origin of a communications problem.

System Tuning and Configuration

INFI 90 OPEN modules can be tuned and configured from the console over the communication highway. Key lock and password security protect against unauthorized tuning and configuration changes.

A tuning display is available to tune control loops. The display can be used to present data and allow tuning of a control station. The tuning display includes a:

- Manual/auto station for the loop.
- Trend element for fast monitoring of control output, set point, and process variable during tuning.
- PCU block detail element for adjusting loop tuning parameters.

A block details display gives the ability to tune selected function blocks. PCU module configuration and management utilities also support both module configuration and tuning.

Display Configurator

Displays are designed on the Elsag Bailey engineering work station (EWS) using an interactive, command oriented display generator called graphical display configurator (GDC). This display configuration combines free-form drawing and text configuration capabilities with standard symbols and display elements to provide an efficient engineering tool. The GDC tool is part of the console configuration tools (WLDG).

A set of standard symbols most commonly used in display design are provided with the console and console configuration utilities software. These symbols are incorporated into displays

as either static or dynamic elements. Provisions are included for separate user symbol sets, which permits custom symbols to be established and saved for repeated use.

An engineering work station running the console configuration tools and connected to the INFI-NET communication highway has the ability to create then transmit displays to an on-line console. After receiving a transmitted display, the display is automatically processed and is immediately available for call-up. Display transmission does not interrupt normal operation and does not require any special setup.

Operator Configurable Displays

Operator configurable displays allow easily grouping critical combinations of process variables for effective process management during abnormal conditions. The displays can be built on the console. Up to 25 displays can be configured in a menu driven fashion. Each operator configurable display can include standard faceplates of all tag types (e.g., manual/auto station, device driver, etc.), trend elements, and alarm summary elements. If desired, these displays can be made permanent for use in normal operations.

Alternate Language

Various alternate language character sets and keyboards are supported. Phrases and key words used throughout the system can be configured to be either English or alternate language. These include such things as week day, station modes, operator messages, engineering units, etc. Any tag descriptive attribute is selectively configured for English or alternate language.

OPERATING THEORY

The console processes information from messages it receives over the communication highway and performs control with messages it sends on the highway. It does this through its multibus modules that provide the interface to the loop. These modules make up the communications interface unit for the console.

During start-up or reset, the entire tag and trend databases are downloaded to the interface unit. The database provides information the interface unit needs to establish communication with individual points in the process. After downloading is complete, the interface unit both transmits and receives messages as directed by the console. The interface unit also provides data storage until the console is able to process any received data. Communication modules handle the data transfer between PCU modules and the communication highway.

Message types include:

- Data transfer.
- Exception reports.
- Module status.
- Process control.
- Trend data.
- Tuning and configuration.

Data Transfer Data transfer messages are generated by the console to read analog real values or digital states and the status of these points from a control module. These process variables can then be displayed or stored for later viewing. This is a request/reply message sequence. A data request message is sent to a PCU module, then the module replies with the requested data.

Exception Reports Exception report data appear as dynamic values, alarms, and state changes. Initially, a message is generated to establish an exception report route between the console and a PCU module. After establishing a point, exception reporting becomes automatic. PCU module exception reports are sent periodically to update values, after a process point reaches a defined alarm limit or changes state, or after a significant change in value occurs. There are several alarm indicators that can be communicated in an exception report message.

Module Status Module status request messages are generated by the console to read then display module status and problem reports. The status of most PCU modules can be requested. A module status request from the console causes a module to reply with its status bytes and a detailed problem report.

NOTE: Not all PCU modules are capable of sending status byte or problem report information.

Process Control Process control messages are generated by the console after control has been initiated from the keyboard or a touch pad. These messages allow performing loop (station) and device control from the console.

Trend Data Trend data messages are sent to retrieve historical process information collected by the INFI 90 OPEN distributed trending system. This information is necessary for process trend analysis (trending) and process evaluation. A trend data message initiates a request/reply data transfer sequence. A request is sent for trend data, then a PCU module replies with the requested, collected, time-stamped data.

Tuning and Configuration Tuning and configuration messages are generated by the console to manage PCU module configurations. The management capabilities include reading, writing, deleting, and tuning function blocks.

Access to the INFI 90 OPEN system is necessary for three purposes:

- Control engineering.
- Plant operation.
- System troubleshooting.

Control Engineering

Access to PCU module configurations enables the following functions for creating and maintaining configurations:

- Change module operating mode.
- Copy a configuration from module to disk (save).
- Copy a configuration from disk to module (restore).
- List module configuration to printer.
- Red tagging.
- Verify configuration against disk.

NOTE: Red tagging is for status purposes only and does *not* prevent operation of equipment. Red tag status communicated to the console alerts personnel to equipment or system problems which could cause damage or injury.

The CONFIG/TUNE key lock switch and password security protect against unauthorized use of these module configuration capabilities.

Plant Operation

The console can be used to monitor the process and take control when necessary. After the system is configured, exception reports that contain the process variables for selected control points travel to the console from other nodes over the communication highway. This data is received then displayed and stored. Operator actions at the console automatically send messages to PCU modules to initiate control. PCU modules directly interface with the process after receiving information entered from a console.

NOTE: Taking the console off-line or a console failure in the INFI 90 OPEN system has no affect on control configuration execution by PCU modules.

Exception reports update process values displayed by the console. The amount of change that is significant, maximum and minimum limits for alarming, and maximum and minimum time (in milliseconds) for exception reporting are set during module configuration. The exception report process enables the display of current data without continuous polling.

PCU control modules can send exception reports for individual variables or a collection of variables (e.g., process variable, set point, and control output). The address of a function block

originating a report identifies each exception report. The address is a loop, PCU, module, and block number.

A tag represents each exception reporting point in the system. Each exception report point to be monitored must be defined as a tag. The tag enables access to the point for monitoring and control.

A structured view of the plant can be designed into operational displays. After being configured, all monitoring and control can be performed by using these displays and the keyboard. Two main categories of operational (data) displays are used: Summary and status displays and process monitoring and control displays.

SUMMARY AND STATUS DISPLAYS

The summary and status displays provide a broad view of plant processes. The current information relating to INFI 90 OPEN equipment, process variables, alarms, and console operations can be viewed from these displays. Standard summary and status display templates are provided which can be used as is or modified.

Displays of this type are usually in a tabular format. Most are assigned to dedicated keys by default; however, others must be assigned to function keys during console configuration for easy, one-key access.

Alarm Summary An alarm summary can be used to review the status of up to 1,000 most recent alarms. The number of alarms that are saved and appear in a summary is configurable.

Display Summary A display summary can be built to contain a complete list of all displays in the system. This display can be created to enable viewing a complete list of system displays and to enable calling each display in the list from the keyboard or by touch point selection.

Log Status A log status page shows the type, configuration parameters, printing status, and current collection status (i.e., active or inactive) for custom logs and sequence of events logs. It also allows activating or deactivating log collection and canceling queued log prints. The log status page is integrated into console operations and cannot be modified.

Operating Parameters An operating parameters page identifies the current operating conditions and parameters for a tag. It displays the tag type, hardware address, and alarm limits. Operating parameters functions can be used to control reporting abilities (i.e., scan on or off), inhibit alarming, substitute values, and view the primary display for a tag. In some cases, the page has selections for viewing the block details, tuning, and module problem

report displays depending on the tag selected. These are all console level operations. In other cases, the page presents options that directly control the operation of a function block in a PCU module. The operating parameters page is integrated into console operations and cannot be modified.

Tag Summary A tag summary will present the current database status for a selected tag or group of tags. The status can be called to the screen or printed. The tag summary page is integrated into console operations and cannot be modified.

PROCESS MONITORING AND CONTROL DISPLAYS

Process monitoring and control is performed by using graphics displays designed to represent the overall plant process, detailed process unit or area, and individual plant devices. Displays can be configured as static informational pages or interactive, dynamic operational displays. These types of displays provide detailed information on process variables and allow manual control of process points.

Block Details Display The block details display gives access to a configured block in a PCU module and displays the specifications and operating parameters for that block. Parameters affecting the operation of a PCU module can be tuned from this display.

Group Display A group display provides real-time process information to support control actions. This type of display consists of a group of related faceplate format elements (i.e., device mimics). Each faceplate represents an actual process control point or variable. This type of display is normally called from a higher level graphic.

Process Detail A process detail display presents a combination of graphic process mimics and faceplates. This type of display provides a more detailed view and allows control of specific related process points. It combines the process mimic and device mimic capabilities into a single display. A process detail display is also normally called from a higher level graphic.

Process Overview A process overview display provides live, dynamic process information to support control actions in schematic format. These interactive displays can contain dynamic symbols, dynamic process variables, and display and control select elements.

Tuning Display A tuning display allows tuning, trending, and controlling a single station. It also gives the block details for the function block controlling the station. The affects of any changes made from this display can be viewed on a trend graph that is part of the display.

System Troubleshooting

A series of system status pages allow monitoring the operational status of INFI 90 OPEN equipment on the communication highway. Each level of status page can be used to narrow a problem down to a specific module. The status information presented for a particular module is in the form of module status bytes and problem reports.

Module Status A module status page gives a detailed status review of a single module. It monitors and displays the status bytes and problem reports.

Module Firmware The module firmware display gives firmware levels for modules in any given process control unit. This display also presents the type and current mode of each PCU module.

Node Status A node status page reviews the status of each module within a process control unit. It displays both normal and problem conditions.

System Overview A system overview page gives an overview of operational status of INFI 90 OPEN equipment on the loop. It displays both normal and problem conditions.

Topology Summaries A series of topology displays give an overview of communications status for the loop the console connects to and individual nodes on any loop.

TRENDING

INFI 90 OPEN distributed trending system data can be retrieved by the console. PCU modules perform the actual data collection and storage of data. The data can be presented in trend or XY plot displays, recorded in custom logs, and archived to storage media for later analysis of process operations.

Distributed Trending

Through a trend block, a PCU module collects data for trending and performs the initial data compression and calculations for the trended data. This, and not the attributes defined during trend definition, determines the actual values a module sends to the console.

Data can be collected from two different types of trend blocks. A standard trend uses function code 66 (FC 66) to perform its data collection. An enhanced trend uses function code 179 (FC 179) to perform its data collection.

STANDARD TRENDING (FC 66)

Any analog exception reporting function block can be trended using the standard trend block. A digital point can also be trended but requires some additional setup and signal conditioning in the control configuration.

A trend block determines how often the PCU module collects data for a trended point. For a standard trend, data can be collected at two different resolutions: 15 seconds or one minute. Resolution refers to the amount of time between data samples. Normal trending stores values at one-minute intervals; fast trending stores values at 15-second intervals.

Another characteristic determined by the trend block is the mode of collection for a trend. For a standard trend the collection modes are sample, maximum, minimum, sum, or average. This determines the final value that a module sends to the console based on the values seen during the resolution interval (i.e., 15 seconds or one minute).

Average	The module calculates the average of all values collected during the 15-second or one-minute interval.
Maximum or Minimum	The module saves either the maximum or minimum value seen during the 15-second or one-minute interval.
Sample	The module saves a value every 15 seconds or one minute.
Sum Mode	The module calculates the total of all values collected during the 15-second or one-minute interval.

ENHANCED TRENDING (FC 179)

An enhanced trend provides additional capabilities beyond those available in the standard trend block. It provides flexibility in both types of data that can be trended and in sampling resolution. The function blocks that the enhanced trend block allows direct trending of include:

- Analog exception report (FC 30).
- Digital exception report (FC 45).
- Remote control memory (FC 62).
- Remote manual set constant (FC 68).
- Control station (FC 80).
- Device driver (FC 123).
- Multi-state device driver (FC 129).
- Remote motor control (FC 136).
- Data acquisition analog (FC 177).
- Data acquisition digital (FC 211).

NOTE: Enhanced trending requires INFI-NET communication highway.

The enhanced trend block also determines how often the PCU module collects data, but it provides greater resolution in its collection than a standard trend. An enhanced trend block can collect and store data at a resolution of one sample per second.

Another characteristic determined by the PCU module is the mode of collection for a trend. For an enhanced trend block the collection modes are sample, maximum, minimum, sum, average, or range. This determines the final value that a module sends to the console based on the values seen during a statistical time period.

Average	The module calculates the average of all values collected during the statistical time period.
Maximum or minimum	The module saves either the maximum or minimum value seen during the statistical time period.
Range	The module calculates the value as maximum minus minimum samples collected over the statistical time period.
Sample	The module saves a value based on the input sampling time set in the trend block.
Sum	The module calculates the total of all values collected during the statistical time period.

Local Trend Data Collection

A local trend must be defined in the trend database to access data collected by a PCU module trend block. The trend database establishes a list of trends for which the console is to collect data. Trend definition can be performed on the console or by using the console configuration utilities program.

Data is collected from PCU modules over the communication highway. A trend definition references a trend block in a PCU module. This establishes a connection for communication between the console and trend block. After the communication is established, trend data poll messages are initiated by the console and directed to the PCU module to collect data. The module replies with the requested, collected, time-stamped data. Communication with a point is established during trend definition, and after console start-up or reset.

A PCU module capable of trending can store approximately 30 minutes of data for a standard trend. Under normal circumstances, the console polls the module prior to the 30 minutes to collect data and prevent any data loss. For an enhanced trend, the module sends a trend data notification message to indicate that the console needs to poll the module for trend data. The console responds to the notification by polling the module for the data. There is no fixed time of collection for the

console. A PCU module does **not** send any trend data until it is requested.

For a standard trend, trend data loss occurs on the console if the console is turned off for more than 30 minutes. This can be seen as a gap in a trend line on a trend display. For an enhanced trend, data loss occurs if a request for data is not made before the module begins to overwrite old data. The buffer size set in the enhanced trend block determines how many events the module saves before it begins to overwrite data.

The trend data received after polling a PCU module is stored in a trend data file (**TR**). Each trend definition has a corresponding trend data file. Up to three months of data can be maintained in the file for a standard trend. For enhanced trends, the maximum number of events saved to disk, as set during trend definition, determines the amount of data stored in a trend data file. Archiving functions allow storing and retrieving this data indefinitely.

While viewing a trended variable in a display, the PCU module is polled almost continuously to collect data. The display is updated every 15 seconds or one minute for standard trends. For an enhanced trend, the display is updated at the display resolution defined in the display.

Remote Trend Data Collection

For a remote trend, a request is made to an open access system for historical trend data. The open access system has its own trend database and is responsible for collecting and storing data from the INFI 90 OPEN distributed trending system. It does this in the same way as local data collection performed by the console. A trend must be defined in both the open access system and console databases to perform remote trend data collection.

Remote trending is for display purposes only. No data is stored by the console for a remote trend. The open access system provides the historical data storage for display, logging, and archiving purposes.

When viewing a remote trend on the console, a request for historical data is first made to the open access system, not a PCU module. The trend display is then continuously updated by implementing local data collection while the trend remains on the screen. After exiting the display, local data collection terminates. Data is collected from an open access system over the DECnet network, not the communication highway.

TIME-STAMP

Communication highway time synchronization establishes a common system time (absolute time) for all nodes on the loop. A controller module collects and time-stamps data with this system time.

A node designated as the time-sync master maintains system time for all nodes on a loop. The time-sync master maintains the time by issuing a module time-sync message directed to the communication modules of each node on the loop. The communication modules verify then relay the time in this message to their local modules. A module processes a time-sync message only while in execute mode. A communication module sends a time-sync message to its modules:

- When a module first starts up.
- After a module changes from configure to execute mode.
- After it receives a new time-sync message.

A module that is sent a set time command message from a communication module must reply to acknowledge receipt of the message. If the reply is not received by the communication module, the time-sync sequence repeats.

The console can become the time-sync master on a loop. Normally it becomes the master when the *Set Time and Date* function is used to either adjust the local time or initialize the system time. If there is more than one console in the system, the consoles perform an arbitration process to establish a time-sync master. This allows the console with the most accurate external clock to assume the responsibility of maintaining the system and local time. Refer to **SET DATE AND TIME** in Section 20 for further explanation.

Exception Report

When data is received in an exception report, one of two things happens depending on console configuration. If the console has module time-stamp enabled, the time-stamp received in the exception report is used in the event log and alarm summaries. The displayed, printed, and saved time for these two reports is to the tenth of a second. The event log and alarm summaries will be maintained in chronological order.

If the console does not have module time-stamp enabled, the time the console reads the exception report is the time used in the event log and alarm summaries. The time is to the second. Some events or alarm changes may appear out of order in the event log and alarm summaries.

Console

The same is true for an operator action that is logged by the console as is for an exception report. If the console has module time-stamp enabled, the displayed, printed, and saved time for an operator action in the event log is to the tenth of a second. If the console does not have module time-stamp enabled, the time is to the second. Refer to the discussion on module time-stamp configuration in the **Configuration** instruction for the procedures to enable module time-stamp for the console (Table 1-2 lists instruction numbers).

For all other time-stamping functions, such as custom logs, operator information events, operator action requests, etc., the time stamping is always performed by the console. The time is to the second. For example, the time associated with a logged value is the time at which the value was read and logged by the console.

USER TASKS

Two separate user task features are provided: @aGlance/IT™ and user task interface. Only one user task feature can be active on the system.

@aGlance/IT

@aGlance/IT is activated when the operating software is installed. It provides the capability for remote clients to access @aGlance/IT servers in the INFI 90 OPEN system and acquire system data, such as trends, alarms, events, and operator actions. This data can then be analyzed by spreadsheet application software. Refer to the @aGlance/IT documentation for specific spreadsheet packages that @aGlance/IT is compatible with.

@aGlance/IT can be configured to safeguard console operations from possible interference, either intentional or accidental. A description of @aGlance/IT operational commands can be found in the **OPEN Data Server/Client** instruction (Table 1-2 lists instruction numbers).

An @aGlance/IT server program runs on the host DECstation. The activation of a user-written program command from the console can be tied to:

- Assignable function key.
- ADP pushbutton.
- Touch point.
- Key select (i.e., **A-1**).

Refer to the discussion on @aGlance/IT configuration and definition in the **Configuration** instruction for the console

requirements to define a server program. Also, refer to the instruction for the procedures to assign a server program to a function key or an ADP pushbutton (Table 1-2 lists instruction numbers).

One client/server is supplied as part of the operating software, and allows for only one client connection at a time. A licensed server, however, provides the capability to support simultaneous client access. Contact Elsasg Bailey for more information on the @aGlance/IT software and user-written programs.

User Task Interface

A user task interface (UTI) provides the capability to create user-written programs to access INFI 90 OPEN process data. The user task interface can be used to implement such things as custom calculations or custom reports that encompass a small number of tasks. In order to use the user task interface, @aGlance/IT must be disabled. Refer to the **Configuration** instruction for the procedures to disable @aGlance/IT and enable user task interface (Table 1-2 lists instruction numbers).

NOTE: The UTI function is intended to implement moderately sized user-written programs. It is not intended as an INFI 90 OPEN interface for large third party or user systems such as plant wide historians and data analysis packages. Elsasg Bailey offers other platforms for this purpose.

The user task interface provides a means to extract INFI 90 OPEN process data from the console by using specialized user-written programs. Also, it provides an environment that allows the programs to employ the full capabilities of the DECstation running the OpenVMS operating system. It does this while safeguarding console operations as much as possible from either intentional or accidental interference. Contact Elsasg Bailey for more information about the user task interface and user-written programs.

A user program can be run from the UTI account on the host DECstation. The activation of a user-written program from the console can be tied to:

- Assignable function key.
- ADP pushbutton.
- Touch point.
- Key select (i.e., **A****1**).

Refer to the discussion on user task definition in the **Configuration** instruction for the console requirements to define a user task. Also, refer to the instruction for the procedures to assign a user task to a function key or an ADP pushbutton (Table 1-2 lists instruction numbers).

SECTION 3 - KEYBOARD AND PERIPHERALS

INTRODUCTION

This section describes the keyboards, annunciator display panel, and printers. For keyboards, it describes the layout and gives a brief description of the keys on the operator keyboard. The key descriptions given in this section are intended to be used only for quick reference. Other sections in the instruction provide detailed information for those keys requiring additional explanation.

KEYBOARDS

The keyboard is the primary interface between the operator and the console. During operation, the keyboard is used to perform process monitoring and control and to perform system troubleshooting and module configuration. The keyboard enables entering process changes and values, processing alarms, and selecting displays. The keyboard is also used to configure the console.

Two types of keyboards are supported: A standard operator keyboard and an auxiliary engineering keyboard (QWERTY style). Both types provide the same access to functions. The layout of each type of keyboard is different to facilitate specific kinds of operations. The operator keyboard is designed for operating ease when performing all normal process operations. The QWERTY layout engineering keyboard is designed for ease of data entry. The auxiliary keyboard is either an IIAKB02, IIAKB03, or LK-201 type.

This section describes each block of the standard operator keyboard identifying its keys and their functions. Most operator keyboard keys are mapped to the auxiliary engineering keyboard. Refer to [Appendix A](#) for auxiliary keyboard key mapping. Figure 3-1 shows the operator keyboard layout.

Keyboard Operation

Two very different operator input device interface channels are employed by the console: Keyboard interface and X window interface.

Keyboard Interface

The keyboard interface allows input from the operator keyboard. It supports annunciator display panels (ADP), key lock, tones, and relays. Using this interface allows assigning a keyboard to a window using **SWITCH CRT**. The keyboard can be assigned to a window even if the window appears on the screen of another console or station.

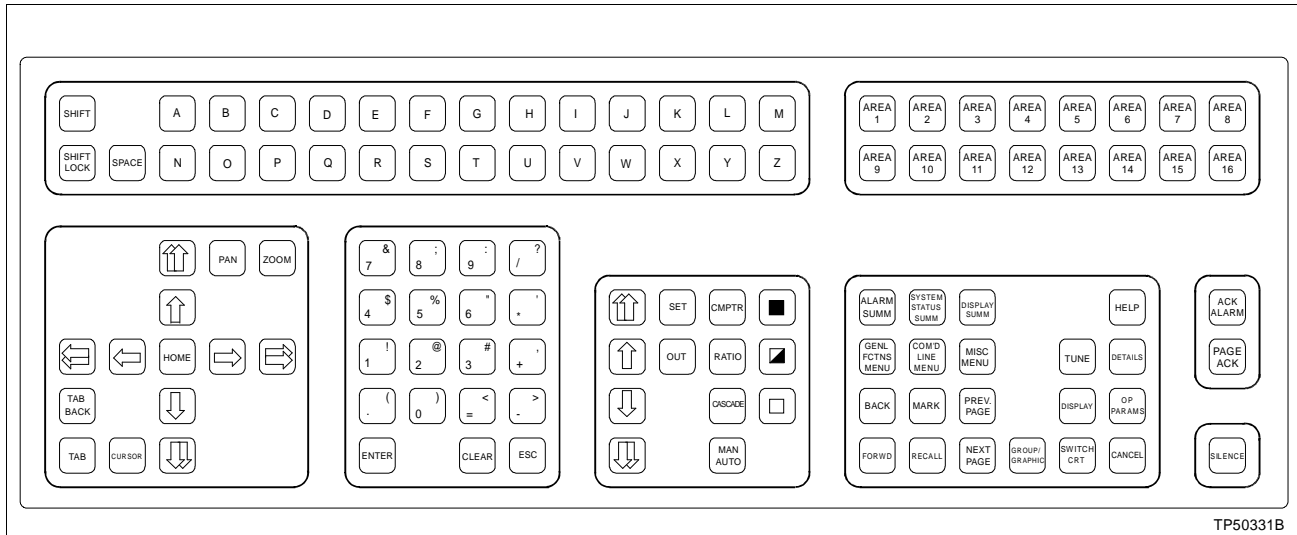

Figure 3-1. Operator Keyboard

X Window Interface

The X window interface provides full X window capability from an X keyboard and a mouse. Both the operator keyboard and the auxiliary engineering keyboard are X keyboards. The X keyboard can be assigned to any window that appears on the screen directly connected to the same station as the keyboard. Placing the mouse pointer anywhere in the window and clicking the left mouse button assigns the window to the keyboard. The title bar changes color to indicate that the window to keyboard assignment has been made. In the X environment, this is referred to as **setting input focus**.

A keyboard type is identified during keyboard definition as either MKM2 (keyboard interface) or XKBD (X window interface). Refer to the discussion on keyboard definition in the **Configuration** instruction for an explanation (Table 1-2 lists instruction numbers).

NOTE: The console cannot be run without a keyboard and a mouse or trackball connected.

Keyboard Error

The console monitors the status of its keyboards. If it cannot communicate with a keyboard for any reason, a flashing A appears at the title line in the upper right corner of the OIS application window. This indicates an operator action request and notifies that some action is required. A message on the operator action requests display will indicate the problem keyboard. After the problem is fixed, the keyboard can be put back into operation by acknowledging the message on the operator action requests display. Refer to **OPERATOR ACTION REQUESTS** in Section 17 for the procedures to process a request.

KEYBOARD LAYOUT

The operator keyboard is a flat panel divided into blocks of related pushbutton keys. Pressing any key provides both tactile and audible feedback. Each block of keys relates to a specific type of operation (Figure 3-2).

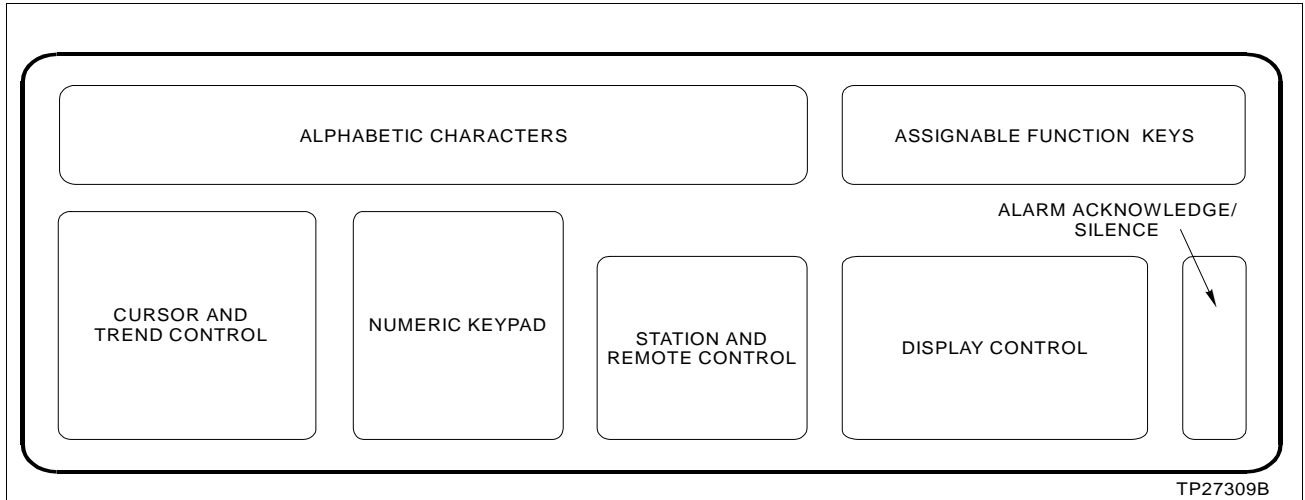

Figure 3-2. Keyboard Sections

Display Control

The keys in the display control block give single key access to the different configuration and operational displays available on the console. This block also provides keys for moving between the different displays. Table 3-1 describes the function of each display control block key.











Table 3-1. Display Control Block Keys

Key	Function
ALARM SUMM	Calls an alarm summary display. By default it calls the ALMSUMFL.DU display. Any user-created alarm summary can be assigned to the key.
BACK	Recalls the previously selected display. When pressed repeatedly, moves through the last six displays most recently called.
CANCEL	Cancels an operation. It is the first key in a two-key sequence. After the key is pressed, an ENTER function to be canceled prompt appears.
	Used with CURSOR to remove the alarm tabbing cursor.

Table 3-1. Display Control Block Keys (continued)

Key	Function
	<p>Calls a list of options that appear at the bottom line of the window. The command line menu options are:</p> <p><i>ASGN PRN</i> - initially defines or changes printer assignments. This determines where a print-out initiated from the keyboard such as a print tag list, print trend list, or tag summary print will be directed.</p> <p><i>CALC</i> - provides an on-line, four-function calculator to perform addition (+), subtraction (-), multiplication (*), or division (/). Refer to CALCULATOR in Section 7 for more information.</p> <p><i>CRT OVRD</i> - redirects the next display call-up to another window. Subsequent display requests from the current window resume using the default, current, or configured window as normal. Refer to Redirecting a Display Call-Up in Section 7 for more information.</p> <p><i>LOG OUT</i> - logs out the current password and logs in a default password. Refer to SECURITY PASSWORD in Section 7 for more information.</p> <p><i>LOG/NAME</i> - gives access to the <i>Log by Name</i> function for printing configured logs. Refer to PRINTING AND DISPLAYING LOGS in Section 18 for more information.</p> <p><i>NOTE</i> - calls an input field that allows entering notes into the event log. Refer to NOTE in Section 7 for more information.</p> <p><i>PASSWORD</i> - calls an input field to log in a password (user). Refer to SECURITY PASSWORD in Section 7 for more information.</p> <p><i>PRINT</i> - initiates a screen print of the current display to a selected printer. Refer to SCREEN COPY in Section 8 for more information.</p>
	<p>Calls the block details for a selected tag on the display. If no tag is selected, a prompt appears requesting a tag name or index number or a loop, PCU, module, and block number. Refer to BLOCK DETAILS in Section 11 for more information.</p> <p>After selecting a tag by using the input field or the mouse or trackball, control of that tag is automatically enabled if the <i>Build Select Tag Table</i> field has been turned on during system configuration.</p>
	<p>Calls the primary display for a selected tag. The tag must have a primary display assigned to it before this key can function for the tag. A primary display can be assigned to a tag during tag configuration, only one display per tag.</p>
	<p>Calls a display summary. The key is intended to be used to call a display created to contain a list of all available process related displays. If desired, a display select function can be built into the graphic for each display in the list to enable calling a display directly from the list. If a display is not created and assigned, the key calls a blank display.</p>
	<p>Provides the same function as BACK except it starts with the last of six previously selected displays and moves forward to the most recent.</p>
	<p>Displays the following menu:</p> <ul style="list-style-type: none"> <i>A OIS Configuration</i> <i>B OIS Utilities</i> <i>C OIS Operation</i> <p>Refer to Section 5 for a tree structured view of the menu hierarchy.</p>
	<p>Does not function in this software release.</p>

Table 3-1. Display Control Block Keys (continued)





Key	Function
	<p>Calls a help display. The key is intended to be used to call a display created to give instruction on system and console operations. It is normally used to call the highest level help display in a hierarchy of help displays. If a display is not created and assigned, the key calls a blank display.</p>
	<p>Flags the current display for later recall. This is similar to using a book page marker. Up to ten displays can be marked. To use this function, press MARK then a numeric key (0 to 9). The display can then be recalled at any time using RECALL. For example: MARK 2</p>
	<p>Displays a full size menu that gives access to the following options:</p> <p><i>Display by Name</i> - used to call a display by entering its name. The name must be of an assembled display file without its DU extension. The option can be used to call any type of display including an operator configurable display.</p> <p><i>Log by Name</i> - initiates a printout or display of a custom, SOE, events, or operator actions log.</p> <p><i>Log Status</i> - used to view the status of both custom and SOE logs. The status function provides the ability to activate or deactivate log collections and to cancel queued prints.</p>
	<p>Accesses the next page when a function uses multiple pages (e.g., alarm summary, tag summary, etc.). Normally used in conjunction with PREV PAGE.</p>
	<p>Calls the operating parameters display for a tag. This display presents information relating to the configuration of the tag and its operation. Refer to OPERATING PARAMETERS in Section 13 for more information.</p>
	<p>Accesses the previous page when a function uses multiple pages (e.g., alarm summary, tag summary, etc.). Normally used in conjunction with NEXT PAGE.</p>
	<p>Recalls a display flagged with MARK. To use this function, press RECALL then the number assigned previously. For example: RECALL 2</p>
	<p>Toggles the keyboard assignment between a primary and secondary window. The status information relating to a window appears at the lower left corner of the window. The toggle ability must be enabled during system configuration.</p> <p>If operating with more than two windows, this key calls an input field to specify to which window to switch.</p>
	<p>Calls a system status display. The key is intended to be used to call a display created to show the status for nodes, control modules, communications modules, and power supplies. It is normally used to call the highest level system status display in a hierarchy of status displays. If a display is not created and assigned, the key calls a blank display.</p>
	<p>Calls a tuning display for a selected STATION tag. A tuning display allows modifying tunable parameters that affect process operation. Refer to TUNING DISPLAY in Section 11 for more information.</p> <p>After selecting a tag by using the input field or the mouse or trackball, control of that tag is automatically enabled if the <i>Build Select Tag Table</i> field has been turned on during system configuration.</p>

Alphabetic Characters

The keys in the alphabetic character block are used to input character strings, select menu options, or select display elements. The keys in this block include the 26 letters of the English alphabet and **SPACE**, **SHIFT** and **SHIFT LOCK**. Table 3-2 describes the function of each alphabetic character block key.

The console is case sensitive. When entering characters, take note of upper or lowercase. For example, entering **tagname** will not call a tag named TagName. Additionally, all file names must be entered and menu selections made using uppercase letters. After start-up or reset, the default is uppercase letters.

Table 3-2. Alphabetic Character Block Keys

Key	Function
26 alphabetic keys	Enable entering required input strings. Select options or initiate operations when the key that corresponds to a display or control select character is pressed. The display or control select character is defined during display creation.
	Locks the alphabetic character block keys in one of two modes: English language mode or alternate language mode. The current toggle position of this key can be seen in the keyboard status block at the lower left corner of the window. This key only appears on an alternate language keyboard (not shown in Figure 3-1).
	Enables typing lowercase alphabetic characters or upper position punctuation characters in the numeric keypad. Press and hold SHIFT , then press the desired character key. The status of SHIFT LOCK determines if this key enables uppercase or lowercase characters.
	Locks the alphanumeric keys in one of two modes: All lowercase letters and upper position punctuation characters or all uppercase letters, numbers, and arithmetic operators (e.g., +, *, /, etc.). The current toggle position of this key can be seen in the keyboard status block at the lower left corner of the window.
	Fills a character position in an input field with a blank space.



Numeric Keypad

The keys in the numeric keypad block allow entering three types of characters: Numbers, punctuation, and arithmetic operators. The block also contains function keys. Table 3-3 describes the function of each numeric keypad block key. The keypad enables:

- Entering numeric portion of an input.
- Entering any numeric value for operations such as tuning, function block changes, calculations, and control changes.
- Clearing a data input field.
- Entering information into the console.

- Escaping to cancel the current operation and return to a previous operation.
- Entering arithmetic operators in calculations when using the calculator function.

Table 3-3. Numeric Keypad Block Keys

Key	Function
Numeric keys	Enable entering numeric values, punctuation, and arithmetic operators.
	Inputs the value or data typed in answer to a system prompt. Press ENTER after keying in alphanumeric values or character strings in an input field. On some configuration pages, must be pressed after completing any and all changes to enter the changes made and to update the configuration.
	Erases any data from an input field. It can be used to clear an error made while entering data or to clear old data from an input field. If an error is made, press CLEAR before ENTER .
	Cancels a current operation or function from certain pages.
	Exits the current display to return to a previous display.
	Option presented in messages usually along with an enter option to allow aborting an input or operation.

Cursor and Trend Control

The keys in the cursor and trend control block have two functions: Cursor control and trend display control. Cursor control is for data input and display item selection.

An input cursor normally appears as a highlighted field (reverse video) that allows data entry. It can be positioned on any input field by using the control keys. The keys are also used to position an alarm tabbing cursor for acknowledging alarms.

After activating a trend element, the keys in this block perform functions inherent to all trend displays. These functions allow changing the display presentation for better analysis of trended process data.

Table 3-4 describes the function of each cursor and trend control block key.

Table 3-4. Cursor and Trend Control Block Keys















Key	Function
 	Cursor control - move the input cursor one field in the direction of the arrow. Trend control - pan the trend presentation. Depending on the key pressed, each key-stroke causes the display to move either forward or backward in time. Press to move back to a specific time and date or to move forward toward the current time and date. These keys do not bring up the time and date field for panning.

Table 3-4. Cursor and Trend Control Block Keys (continued)

Key	Function
 	<p>Cursor control - move the input cursor one field in the direction of the arrow.</p> <p>Trend control - zoom the trend presentation. This changes the display resolution to increase or decrease the amount of historical trend data displayed. Perform the same function as ZOOM without specifying a zoom factor.</p> <p>It is also used to zoom the trend curve inside a trend magnifying glass.</p>
 	<p>Cursor control - move the cursor within an input field one position in the direction of the arrow.</p> <p>Trend control - move the time pointer in the direction of the arrow. Use these keys to position the time pointer at a specific time. This allows viewing the historical values at the pointer location. They also allow positioning the pointer before enabling the magnifying glass.</p> <p>Used to fine tune the trend magnifying glass position after enabling the glass.</p>
 	<p>Move the input cursor one position in the direction of the arrow when on the key macro definition page.</p>
	<p>Calls a cross hair cursor for alarm tabbing.</p>
	<p>Resets an input field to the text string it held when the display was first called. Allows an input error to be corrected, but must be used before pressing ENTER.</p>
	<p>Used to return to the first page of an active alarm summary display or element.</p>
	<p>Calls a <i>PAN</i> field for panning a trend display. The field allows entering a time and date to move the display to a specific time of historical trend data.</p>
	<p>Cursor control - moves the input cursor to the next logical input field determined by the console.</p> <p>Moves the alarm tabbing cursor between alarming tags on a display to allow acknowledge an alarm. Press ACK ALARM first to call the alarm tabbing cursor.</p> <p>Trend control - moves the input cursor between scale limit input fields of a selected trend element.</p>
	<p>Cursor control - moves the input cursor to the previous logical input field determined by the console.</p> <p>Moves the alarm tabbing cursor between alarming tags on a display to allow acknowledge an alarm. Press ACK ALARM first to call the alarm tabbing cursor.</p> <p>Trend control - moves the input cursor between scale limit input fields of a selected trend element.</p>
	<p>Calls a <i>ZOOM</i> field for zooming a trend display. The field allows specifying a zoom factor (-9 to 9) to increase or decrease the amount of displayed historical trend data.</p>

NOTE: To perform any trend control using these keys, a trend element must first be selected.

Station and Remote Control

The keys in the station and remote control block are used to perform process control. A control element must first be selected to make any changes with these keys. The faceplate

element for either a station, control, or data acquisition function block will reflect any changes made from the keyboard. Refer to [Section 9](#) and [Section 10](#) for more information. Table 3-5 describes the function of each station and remote control block key.

Table 3-5. Station and Remote Control Block Keys













Key	Function
	Changes a selected STATION tag to or from cascade mode. The tag must reference a cascade type station block.
	Changes a selected tag to or from computer mode.
	Selects the alternate input source mode for a DANG or DADIG tag.
	Toggles the selected tag between manual and automatic mode.
	For a STATION tag, automatic mode enables SET and RATIO to change the set point or ratio index of a STATION tag while still under PCU module control. Manual mode enables OUT to change the control output.
	For a TEXTSTR tag, the mode determines how an input from the console is handled by a PCU module.
	Toggles between user input source mode and normal input source mode for a DANG or DADIG tag.
	Displays the current output value of a selected tag. After the key is pressed, a control output <i>TARGET</i> prompt allows changing the value.
	Displays the ratio index value of a selected tag. After the key is pressed, a ratio index <i>TARGET</i> prompt allows changing the value.
	Displays the set point value of a selected tag. After the key is pressed, a set point <i>TARGET</i> prompt allows changing the value.
	Calls a <i>SET U/IN</i> prompt to change the user-inserted value for a DANG or DADIG tag.
	Calls a <i>TGT TEXT</i> prompt to input a text string for a TEXTSTR tag.
	Changes a selected RCM, DD, or RMCB tag to its one state (on). It changes a MSDD tag to its three state.
	Changes the user-inserted value for a DADIG tag to its one state.
	Sets an alarm indication to show that there is an alarm condition associated with a text string entry for a TEXTSTR tag.
	Changes a selected MSDD tag to its two state (mid-state).
	Changes a selected RCM, DD, or RMCB tag to its zero state (off). It also changes a selected MSDD tag to its one state.
	Changes the user-inserted value for a DADIG tag to its zero state.
	Sets a no alarm indication to show that there is not an alarm condition associated with a text string entry for a TEXTSTR tag.
	Ramp a value 0.2% of span per keystroke. Used to make a slow, ramping value change.

Table 3-5. Station and Remote Control Block Keys (continued)

Key	Function
 	Ramp a value 4.0% of span per keystroke. Used to make a fast, ramping value change.

Assignable Function Keys

The user-assignable function keys can be configured to provide single key access to frequently used group, graphic, or summary displays. A function key can also be assigned a:

- Key macro to consolidate multiple keystrokes into a single key.
- User task to allow activating the task.
- Multiwindow display list for calling multiple displays with one key press.

The operation of each of 32 available function keys is established during keyboard configuration. Press **SHIFT** along with these function keys to access the 16 additional function keys (**F 17** through **F 32**).

Alarm Acknowledge and Silence



The keys in the alarm acknowledge and silence block permit acknowledging process or system status alarms (i.e., stopping a flashing alarm indications) and silencing an alarm tone. A process alarm notifies that a process value has exceeded an alarm threshold set in the PCU module. A system status alarm indicates a fault in the INFI 90 OPEN system.

An alarm indicator continues to flash until accessing the display that contains the alarm or an alarm summary and pressing **ACK ALARM** or **PAGE ACK**. This acknowledges the alarm and stops the flashing indications. The alarm indications remain on all displays until a problem is corrected and a process point returns to its normal condition.

SILENCE stops the alarm tone associated with an alarming group or priority. It does not acknowledge alarms for the group or priority. An alarm tone does not sound unless a tone was assigned to an alarm group or priority. Also, if the *Relay Hold until Silenced* field on the general parameters page is set to YES, **SILENCE** opens all relays that have closed due to an alarm condition.

Table 3-6 describes the function of each alarm acknowledge and silence block key.

Table 3-6. Alarm Acknowledge and Silence Block Keys

Key	Function
	Acknowledges process and system alarms. The first time it is pressed, a cross hair cursor appears. After tabbing the cursor to an alarming tag on the display, it acknowledges the alarm for that tag only.
	Acknowledges all tags in alarm on the current display.
	Turns the audible alarm tone associated with an alarm off. Pressing this key does not acknowledge an alarm. Tags continue to flash until they are acknowledged. Opens all relays that have closed due to an alarm condition if the <i>Relay Hold until Silenced</i> field on the general parameters page is set to YES.

NOTE: Only tags with alarm/quality fields displayed are acknowledged when an acknowledge key is pressed.

ANNUNCIATOR DISPLAY PANEL

An annunciator display panel (ADP) extends the standard number of assignable keys. An annunciator display panel provides single key access to critical operating displays.

The intended purpose of the annunciator display panel is to associate a display with an alarm indication; however, it can be used to call any display or function if desired. Associating a display with an alarm indication gives the ability to locate a process value (tag) in alarm with a single key press.

Each panel provides 32 pushbutton and LED pairs. A tag assigned to an LED indicator lamp causes that lamp to light when the tag enters an alarm condition. Any display generated for use on the console can be assigned to a pushbutton. An ADP pushbutton can also be assigned a:

- Key macro to consolidate multiple keystrokes into a single key.
- User task to allow activating the task.
- Multiwindow display list for calling multiple displays with one key press.

After proper configuration, an LED indicator lamp will light to notify when a tag enters an alarm condition. The pushbutton associated with the lamp can then be pressed to call a display. The display called should be one from which appropriate actions can be taken to correct the alarm. Prior to configuration, pressing any of these pushbuttons calls a default blank display.

PRINTERS

Using DECnet gives the ability to connect printers to the network instead of directly to the console. This allows consoles to

share printers connected at terminal servers. A printer can also be connected to an auxiliary console. This printer, however, cannot be accessed by other consoles on the network since the printer is local to the auxiliary console and its associated main console. In either case, the console directs queued prints to a printer over the network.

Up to eight printers can be accessed by a console: four used strictly for logging and the remaining four strictly for screen printing. A utility (i.e., **DEFINEDEVICES**) must be run before the console will recognize a printer. Refer to the **File Utilities** instruction for the procedures (Table 1-2 lists instruction numbers).

A DEVSTAT tag is required to identify the type of printer being used for logging. Refer to the discussion on peripherals in the **Configuration** instruction for a list of printers that can be used for printing logs and **SCREEN COPY** in Section 8 for a list of printers that can be used for printing screens.

The number of physical printers the console is to access for logging is defined on the general parameters page during system configuration. Refer to the discussion on general parameters in the **Configuration** instruction for more information.

Refer to **SCREEN COPY** in Section 8 for the procedures to assign printers for screen printing and to initiate a screen print.

Printer Assignment

Printer assignments are made by using the *Printer Assignment* option and by using the command line menu *ASGN PRN* option.

PRINTER ASSIGNMENT OPTION

The printer assignment page identifies the terminal server port connection for each physical printer and allows designating them as either shared or private. The configuration also defines logical printer assignments. Logical printer numbers, and not physical printer numbers, assign a printer. The printer assignments should be made before any log configuration so that logical printer numbers can be assigned to a log during its configuration. Refer to the discussion on printer assignments in the **Configuration** instruction for additional information (Table 1-2 lists instruction numbers).

ASGN PRN OPTION

The command line menu *ASGN PRN* option assigns a printer to a window. After making this assignment, demanded prints such as tag summaries, print tag list, and print trend list

requests are directed to the assigned printer. This option does not assign a printer used for printing screen copies.

To assign a printer to a window:

1. Press **COM'D LINE MENU**.
2. Press **C** to select the *ASGN PRN* option. An *Enter printer number* prompt appears.
3. Enter a logical printer number from 1 to 9. The keyboard status block should update to show the number of the selected printer. Refer to **KEYBOARD STATUS** in Section 4 for an explanation of the keyboard status block.

Shared and Private Printers

The console can generate a number of different logs. It uses both logical printer assignment and shared or private printer designation to direct the printing of these logs. Logs can be classified into two categories: Page-oriented and line-by-line.

A page-oriented log is one in which an entire log is formatted as a complete document before being sent to a printer. This applies to all periodically scheduled (or demand) logs generated by the console such as custom and SOE logs, and event and operator actions logs when configured to print periodically.

A line-by-line log outputs real-time, individual line entries as they occur rather than as a complete page. The event and operator actions log can be configured to print events or actions immediately as they occur. An immediate printing log prints entries line-by-line rather than as a complete page.

NOTE: Printers must be defined consistently among various consoles.

SHARED PRINTER

A shared printer can be used by any number of consoles (and other stations) on the same network. A shared printer must be connected to a terminal server and not an auxiliary console. A line-by-line log cannot be directed to this printer.

PRIVATE PRINTER

A private printer is dedicated to a single console and can be used only by that console. A private printer can be connected either at an auxiliary console or a terminal server. A line-by-line or page-oriented log can be directed to this printer.

Printer Error or Failure

A printer problem is determined by the number of consecutive retries required to complete a print job. If it is determined that a printer is not available, the console waits a short period of time, then attempts the print again. After a certain number of retries, a printer error will be indicated.

If a printer error is detected, a flashing *A* appears at the title line in the upper right corner of the OIS application window. This indicates that an action request has been entered into the operator action request list. The following message appears as an operator action:

Printer n Powered Down, Disconnected, or Network Problem

After correcting the error, the action request message must be acknowledged by using the operator action requests page to continue printer operations. After acknowledging this error, the print job tried again automatically. Refer to **OPERATOR ACTION REQUESTS** in Section 17 for the procedures to process a request.

NOTE: The time period between retries and the number of retries is set specifically to try and eliminate false error indications. These false errors can be generated when a shared printer is being used by other devices for a long period of time. In this case, acknowledging the error message on the operator action requests page will allow the print request to be tried again.

Printer Failover

A mechanism for printer failover is provided. If a printer should fail, the print jobs queued to the failed printer will be directed to another working printer if failover is enabled. A screen copy printer can only failover to another like printer. After the failed printer comes back on-line, it assumes its previous and any subsequent printing responsibilities. Refer to the **Configuration** instruction for the procedures to setup failover of a logging printer (Table 1-2 lists instruction numbers). Refer to **SCREEN COPY** in Section 8 for the procedures to setup failover for a screen copy printer.

SECTION 4 - DISPLAY SYSTEM

INTRODUCTION

The console presents various display formats on its screen. This section first gives a general explanation of the display system including fixed system display elements and user space. It then explains display control from the keyboard, touch screen, and mouse or trackball.

DISPLAY SYSTEM

All operational displays are user-configurable; however, several standard symbols and text summary templates are provided. Assembled operation, configuration, or summary displays reside in various directories on the hard disk. Table 4-1 lists the standard display templates and symbols provided with the software. The source files for these symbols and templates reside in the [DATA.USN54] directory.

Table 4-1. Display and Symbol File Listing

File (.DT)	Display/Element Type
ALMSUMFL	Alarm summary (full size)
ALMSUMP1	Alarm summary for priority one alarms (full size)
ALMSUMP2	Alarm summary for priority two alarms (full size)
ALMSUMP3	Alarm summary for priority three alarms (full size)
ALMSUMP4	Alarm summary for priority four alarms (full size)
ALMSUMP5	Alarm summary for priority five alarms (full size)
ALMSUMP6	Alarm summary for priority six alarms (full size)
ALMSUMP7	Alarm summary for priority seven alarms (full size)
ALMSUMP8	Alarm summary for priority eight alarms (full size)
ANALOG1	Analog
ANCBOOL1	Digital annunciator
ANCREAL1	Analog annunciator
ANLGCTL1	Analog control
ANLGCPOP	Analog control (pop up)
ANLGHF1	Analog (half height)
ATNKDBL	Atmospheric pressure tank (double size)
ATNKFL	Atmospheric pressure tank (full size)
ATNKFH	Atmospheric pressure tank (half size)
BOOLCTL1	Digital control
BOOLCPOP	Digital control (pop up)
BOOLEAN1	Digital
BOOLHF1	Digital (half height)

Table 4-1. Display and Symbol File Listing (continued)

File (.DT)	Display/Element Type
DADIG1	Data acquisition digital
DADIGPOP	Data acquisition digital (pop up)
DCSFPOP	Control station (full size pop up)
DCSFULL1	Control station (full size)
DCSFULL2	Control station (full size always shows mode)
DCSHALF1	Control station (half size, mode included with tracking)
DCSHPOP	Control station (half size pop up)
DEVDR1	Device driver
DEVDRPOP	Device driver (pop up)
DNGFPOP	Data acquisition analog (full size pop up)
DNGFULL1	Data acquisition analog (full size)
DNGHALF1	Data acquisition analog (half size)
EMODLINE	Enhanced module status line for a status page
ENODSTAXX	Enhanced node status line for a status page
MODLINE	Standard module status line for a status page
MSDEVDR1	Multi-state device driver
MSDEVPOP	Multi-state device driver (pop up)
N90STAT1	System status overview (template)
NODLINE	Standard node status line for a status page
NODSTAXX	Node status summary (template)
RCM1	Remote control memory
RCMPOP	Remote control memory (pop up)
RMCB1	Remote motor control
RMCBPOP	Remote motor control (pop up)
RMSC1	Remote manual set constant
RMSCPOP	Remote manual set constant (pop up)
TEXTSTR1	Text string
TRNDCOFL	Trend box for control output (full)
TRNDCOHF	Trend box for control output (half)
TRNDDGFL	Trend box for digital (full)
TRNDDGHF	Trend box for digital (half)
TRNDPVFL	Trend box for process variable (full)
TRNDPVHF	Trend box for process variable (half)
TRNDRIFL	Trend box for ratio index (full)
TRNDRIHF	Trend box for ratio index (half)
TRNDSPFL	Trend box for set point (full)
TRNDSPHF	Trend box for set point (half)
VALVEDN	Valve down
VALVELT	Valve left
VALVERT	Valve right
VALVEUP	Valve up

Table 4-1. Display and Symbol File Listing (continued)

File (.DT)	Display/Element Type
XY1A	XY plot (MFC data source template)
XYAFL	XY plot analog (full)
XYAHF	XY plot analog (half)
XYDFL	XY plot digital (full)
XYDHF	XY plot digital (half)
XYPFL5	XY plot (tag or trend data source template)

NOTE: For trends and XY plots, the full and half does not refer to size, but rather the attributes that appear for each. When using a half source file for a trend, for example, the tag descriptor does not appear for the trend.

Faceplate symbols are used to represent each tag type as a device mimic. Summary displays are used to show system, tag, and console status information. Menu displays are fixed displays used to call console functions. These displays and symbols already have the necessary interactives built in to enable their functions. Interactives are features built into a display that allow directing operations from the display.

NOTE: If a standard display template or symbol is to be modified, it is suggested that the original file be first copied and renamed. Make the modifications to the new, renamed file rather than the original.

Any standard symbol can be incorporated into any user-created display. Any display either created from a template or completely user-created can easily be incorporated into operations. The standard symbols or templates can also be modified to customize their operations. Menu displays such as the *General Functions Menu* cannot be modified.

Display Characteristics

An x,y coordinate system is used by the console for displays. An x,y coordinate associated with each display element defines the position of that element in the display. An element is any item that is part of a display and can refer to any component from a simple valve to a complete faceplate symbol.

The entire window grid ranges from 0,0 at the lower left corner of the window to 10000,7500 at the upper right corner. To maintain consistency throughout all displays, certain areas of the grid are reserved for fixed elements. The outer segment of the entire grid is reserved for system functions (e.g., date, time, interface unit status, etc.), prompts, messages, and keyboard status. The rest of the grid area (400,400 to 9600,7200) is available as user space for creating graphic, summary, and informational displays and also for system menus.

Many different elements combine to form a complete display, but all pages share a few common features. Each display can

use multiple colors and has a reserved space for a title line and bottom line prompts.

The standard display screen is a 19-inch, high resolution color monitor. The monitor accepts standard RGB (red, green, blue) inputs and is capable of up to 64 solid and 64 flashing colors.

Figure 4-1 shows the common display features and their locations which once setup remain the same for all displays. Figure 4-2 is an example display that shows most display features described.

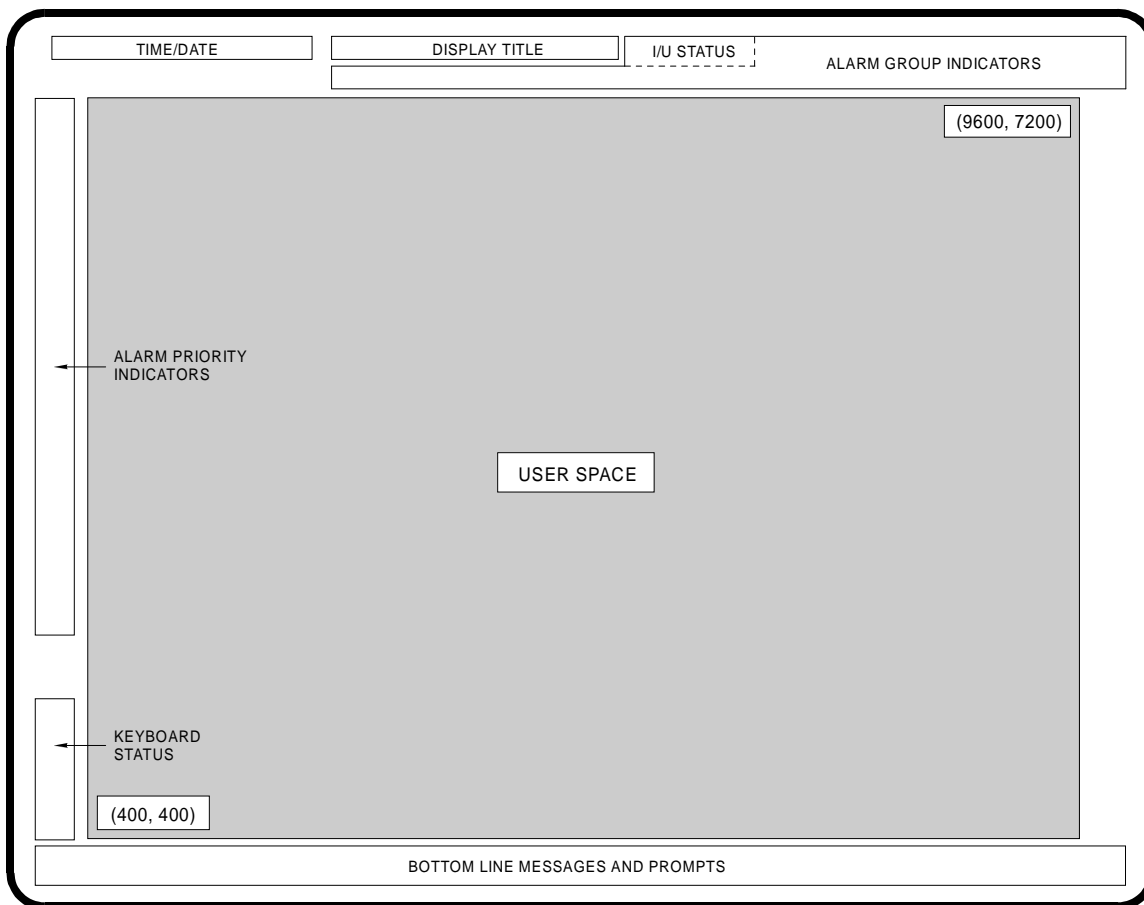

TP27296D

Figure 4-1. Common Display Characteristics

TITLE LINE DISPLAY ELEMENTS

The top two lines of every display are its title line. The information on these lines always has the same format regardless of the display. From left to right it shows:

- Current time, date, and week day (order depends on time and date format configuration).

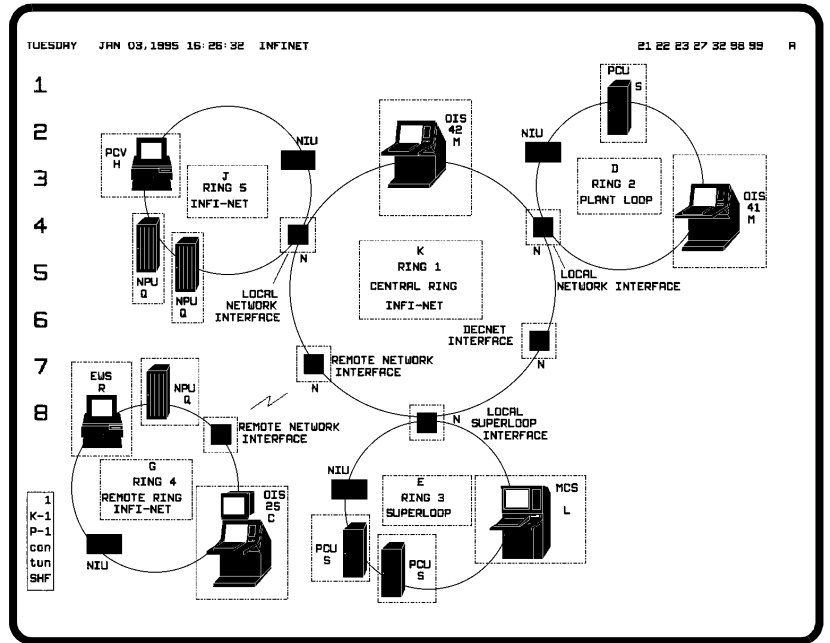

Figure 4-2. Example Display

- Display title.
- Communications interface unit status.
- Alarm group status indicators (system and process) and operator action request indicator.

With standard configuration the title appears in cyan, alarm status indicators in yellow and the remaining information in green.

Time and Date

The time and date are presented in military format by default. The format is hour:minute:second followed by day-month-year, then week day:

23:59:59 20-MAY-96 MONDAY

Time and date format configuration allows changing the order of appearance as can be seen in Figure 4-2.

Display Title

The display title is either the report title or display name. Report titles are fixed while a maximum of 25 characters can be entered for a user-created display. Title position is normally above the user space starting at a coordinate of 3000,7350. The title of the graphic shown in Figure 4-2 is *INFINET*.

Alarm Group Indicators

System and process alarm indicators appear at the title line (Figure 4-2). If a process value exceeds an alarm threshold or a system fault occurs, an alarm group indicator (1 to 99, or S) appears to notify an operator.

An alarm group number identifies the area or a group of process variables containing a process fault. An *A* (action request) appears in this area to notify that some action must be taken before processing can be continued. If no alarms exist, this section of the window remains blank.

NOTE: Alarm group indicators are enabled by default. The indicators can be disabled through alarm management configuration if alarm groups are not being used.

Alarm group indicators display in two lines. The lowest 20 alarm groups display on the top line, right-justified. When this area fills, the remaining alarm group indicators display right-justified on the second line. If both lines fill and there are more alarm indicators to display, an *M* (more alarms) appears right-justified on the second line.

When an alarm indicator first appears it flashes to identify itself as being unacknowledged. After being acknowledged, the alarm indicator stops flashing. When the problem becomes corrected, the indicator disappears.

Interface Unit Status

The status of the communications interface unit is given in the alarm group indicators area. If *CIU offline* is indicated, the interface unit is not communicating on the communication highway and the console is not receiving data from the loop. It is then assumed by the console that all points are in a bad quality condition and a bad quality indication is given for all tag values and status. This does not apply to internal tag types (i.e., INTANG and INTDIG), however. In most cases, resetting the OIS application reestablishes communication with the loop.

NOTE: When the console comes up for the first time, the *CIU offline* message appears. This is normal while the console downloads points to its interface unit.

ALARM PRIORITY INDICATORS

Each alarm level or the alarm state of a process variable and the return-to-normal condition of a process variable can be assigned a priority level from one to eight for alarm management purposes. Also, bad quality when used to trigger alarming can be given a priority. The eight alarm priority indicators

along the left side of the window correspond to the eight different alarm priority levels. The indicators appear only if enabled during alarm management configuration. The indicators appear in one of two different ways depending on configuration: Numeric indicator only or pushbutton indicator.

NOTE: Alarm priority indicators are disabled by default. The indicators can be enabled through alarm management configuration if alarm priorities are being used.

Numeric Indicator Only The alarm priority indicators can appear as numbers (Figure 4-2). In this case, a yellow priority number will appear only when an alarm of that priority is in the alarm summary list. The number will blink if there are unacknowledged alarms with the priority.

Pushbutton Indicator The alarm priority indicators can also appear as pushbuttons. In this case, the priority number within the pushbutton will change to yellow when an alarm of that priority is in the alarm summary list. The number will blink if there are unacknowledged alarms with the priority.

The alarm priority indicators, whether configured as numbers only or as pushbuttons, are touch points that can be used to call alarm summaries. By default the summary called by a particular touch point will contain only the alarms with the priority indicated. For example, selecting the priority 4 touch point calls an alarm summary that shows only priority four alarms.

BOTTOM LINE DISPLAY ELEMENTS

Unlike the title line, the bottom line elements vary depending on the current operation being performed. The following items are some that appear as bottom line elements.

Command Line Menu Various options display across the bottom line after pressing **COM'D LINE MENU**. An input field appears when certain options are selected from this menu.

Input Fields Input fields appear when additional input is needed to complete a desired function. For example, the appropriate prompt allows keying in a name to call up a display or to print a log when using the miscellaneous menu *Display by Name* and *Log by Name* options.

Messages All operator and error messages display along the bottom of the window. This area remains blank if there are no messages. The message number (e.g., *MSG 323* or *ERR 38*) appears to the right of the text message. A message may be up to 50 characters long. Refer to [Appendix B](#) for a description of error messages.

Operator Prompts The bottom line area presents operator prompts and options available while viewing some displays. Depending on configuration, a faceplate element can be set up to present its control prompts in this area. These prompts depend on the type of faceplate element.

KEYBOARD STATUS

The keyboard status block appears in the lower left corner of all displays (Figure 4-2). It presents from top to bottom:

- User index number of the currently logged in user.
- Number of the keyboard assigned to the window.
- Number of the printer assigned to the window.
- Key lock status.
- **SHIFT LOCK** status.
- **ALT LOCK** status for an alternate language console.

The user index number (one to 128) identifies the last user to log in. Users log in by entering their passwords. A password can be entered by selecting the *PASSWORD* option from the command line menu. This is for password security and is different than logging into an account.

A *KB-* field indicates which keyboard is assigned to the window. The number following the *KB-* depends on keyboard definitions made during system configuration. Normally, *KB-1* is assigned to window one, *KB-2* is assigned to window two, etc. Any display that appears can only be manipulated by using the keyboard currently assigned to the window. When a keyboard is not currently assigned to a window, *UNASSIGNED* appears in the keyboard status block of that window.

A *PR-* field indicates which printer is assigned to the window. The number following the *PR-* field is a logical printer number. Any prints initiated from the keyboard will be directed to the printer shown. This does not apply to printing of scheduled logs, which designate a specific printer in their configurations. Also, a screen print occurs at the printer determined by the screen copy function and not this printer assignment.

When the key lock is in either the *CONFIG* (configure) or *TUNE* position, *CON* or *TUN* displays in the keyboard status block in cyan. When the key lock is in the *LOCK* position, *con* and *tun* display in green. The key lock position determines the operations that are permissible.

When **SHIFT LOCK** is locked in uppercase letters, *SHF* appears in cyan. When locked in lowercase, *shf* appears in green.

When **ALT LOCK** is locked in English language mode, *ALT* appears in cyan. When locked in alternate language mode, *alt*

appears in green. This status only appears when alternate language is enabled.

USER SPACE

The user space is the area available for displaying any desired process information. This area can be used to incorporate and display elements such as:

- Static information and values.
- Dynamic process data and symbols.
- Keyboard and touch point display and control selects.
- Station and control device mimics for process control.
- Pop up station and control device mimics.
- Alarm summaries containing current process or system alarms.
- Tabular or XY graph trend elements.
- Text summaries.
- Menu options.

COLOR SCHEME

A standard color scheme is established for the display pages and symbols provided with the console. Similar information is displayed in a specific and the same color to allow quick recognition of the information type. Standard displays present these colors against a black background. Table 4-2 describes the default color scheme. Some colors for display elements can be changed from this standard during configuration.

Table 4-2. Default Color Scheme

Color	Use
Blue	Display, symbol outlines, or inactive menu options. A blue outline for a symbol identifies it as being inactive. A blue selector character in a menu identifies it as being inactive.
Cyan	Static text or prompts that cannot be changed. Also, the outline of an element and a selector character, in some cases, changes to cyan to identify it as being active.
Green	Dynamic items or user-configured data.
Red	Control and display element selectors, menu item selectors, and outline of a red tagged element.
Yellow	Alarm conditions.

Any color scheme desired can be created for user-created displays; although, a standard color scheme is recommended for ease of recognition. In this case, the colors are set during display creation.

Display Element Escape Commands

Escape commands define each static and dynamic display element and enable display capabilities. These commands, defined in a display source file, create the display presentation. A display can be created to include process information and to enable process control and monitoring. Some example commands are:

pg 950,950;100,0;0,-100;0,-100~ - draws a polygon, which can be used, for example, as the outline of a control element or entire display.

ed 42,32,1,1489,1512,124,3,0,7,1,6,2,0 - references a tag with index number one to acquire the dynamic value of an analog process variable.

ei 108,82,48,49,NODSTA01~ - enables calling a display named NODSTA01 from the current display by key select. The key parameters in this escape command identify the display select key combination as **0** and **1**.

Refer to the **Display Builder Reference** instruction for a complete list of escape commands and examples of complete display and symbol source files (Table 1-2 lists instruction numbers).

Either the graphical display configurator (GDC) tool or the elementary line editor (ELE) function can be used to create a display by entering these escape commands. The GDC tool is part of the console configuration tools (WLDG). The elementary line editor is accessed from a terminal window. The difference between the two is that the GDC tool automatically enters the required escape commands and their parameters for each display element based on user entry. The ELE function requires entering an escape command and its parameters for each element of a display as individual line entries. Refer to the **File Utilities** instruction for additional information about the elementary line editor. Refer to the **Console Configuration Utilities** instruction for additional information about the GDC tool.

Another difference in the two is that the GDC tool also provides a graphics presentation while creating the display. Using the elementary line editor requires some prior work to map out the x,y coordinate of each display or symbol element. One method of doing this is by drawing the display as it should appear on a grid having coordinates ranging from 400,400 to 9600,7200. The coordinates for a drawn element can then be transferred to

the display source file as the x,y coordinate parameters of an escape command.

A set of standard symbols and display templates are provided with both the console and the console configuration tools. One method of determining the escape commands required to create a display and present certain types of information is by referencing the provided symbols and templates. The elements incorporated in these symbols and templates can be viewed using the GDC tool or the escape commands defining each element can be viewed by using the elementary line editor.

SECTION 5 - MENU STRUCTURE

INTRODUCTION

Most console functions are accessed by menu selections. This section explains the menu structure and provides a tree structured view of the menu hierarchy for the console.

GENERAL FUNCTIONS MENU

The main menu used as the starting point for accessing console functions is the *General Functions Menu* (Figure 5-1). Press **GENL FCTNS MENU** at any time from any other display to call this menu.

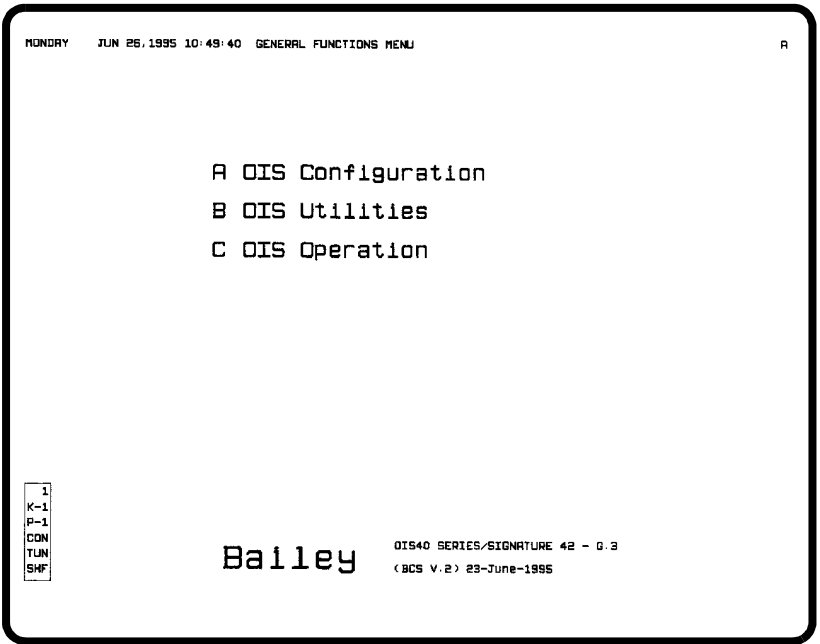

TPS0752F

Figure 5-1. General Functions Menu

The menu has three separate choices, each providing access to a group of related operations, utilities, or configurations. Figure 5-2 shows the menu options accessed after selecting either A *OIS Configuration*, B *OIS Utilities*, or C *OIS Operation* from the menu. Figures 5-3 and 5-4 show the *OIS Configuration* menu structure. Figures 5-5, 5-6, and 5-7 show the *OIS Utilities* menu structure.

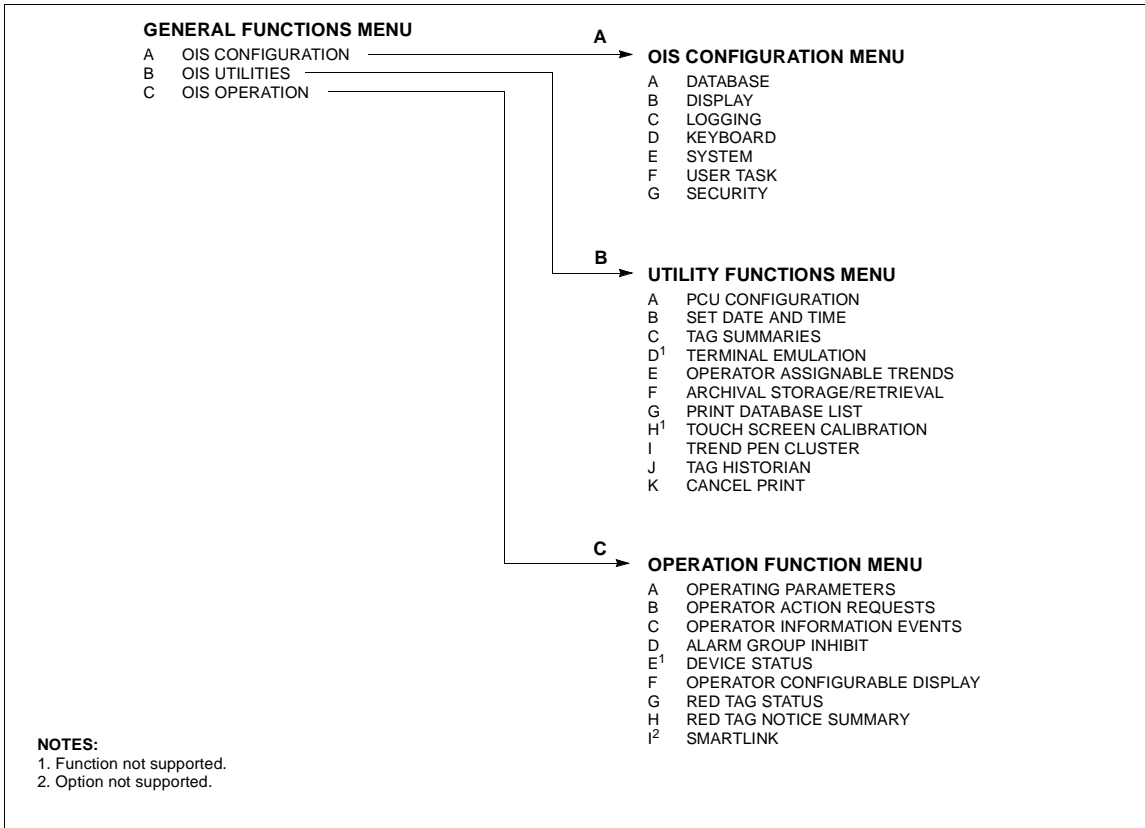

Figure 5-2. Menu Structure - General Functions Menu

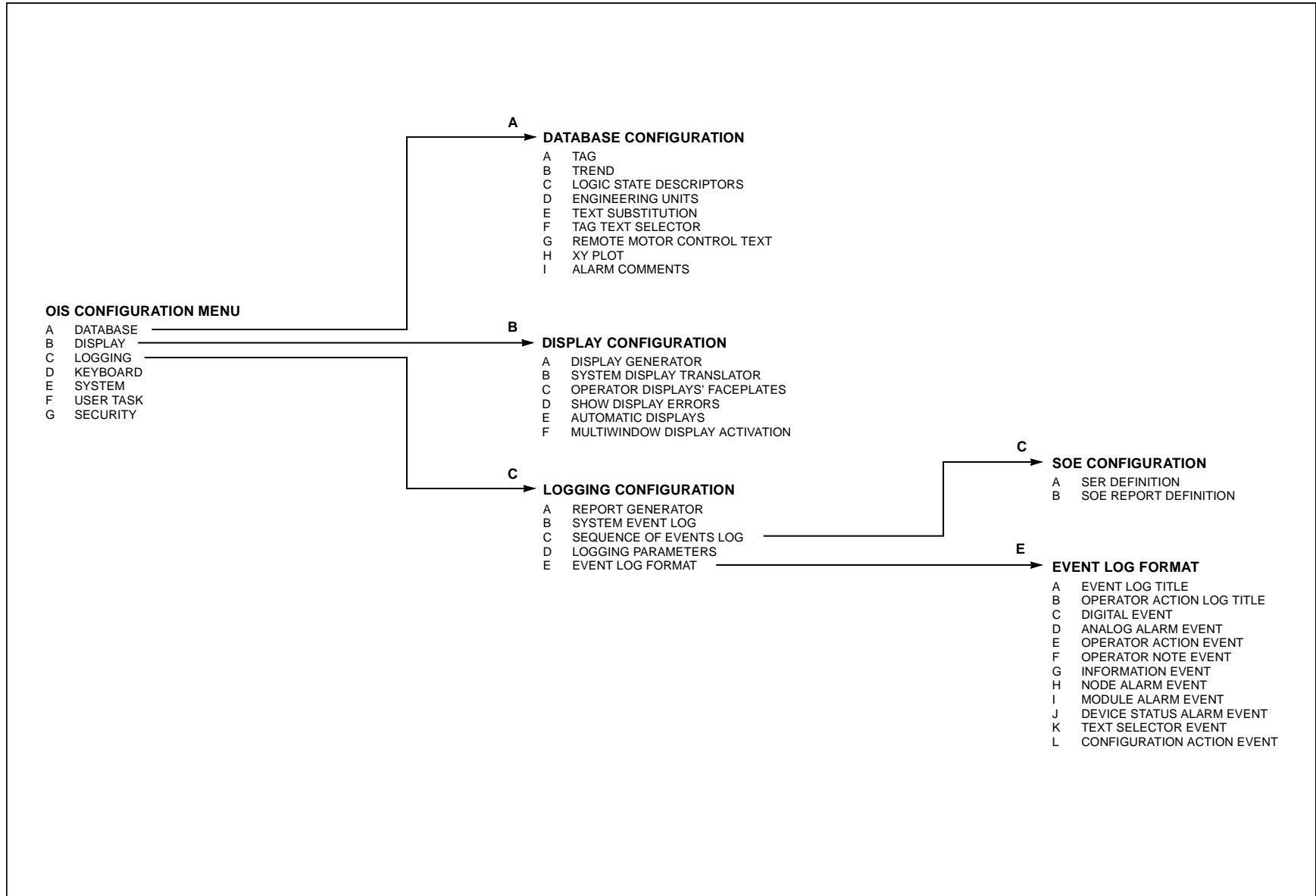

Figure 5-3. Menu Structure - OIS Configuration (1 of 2)

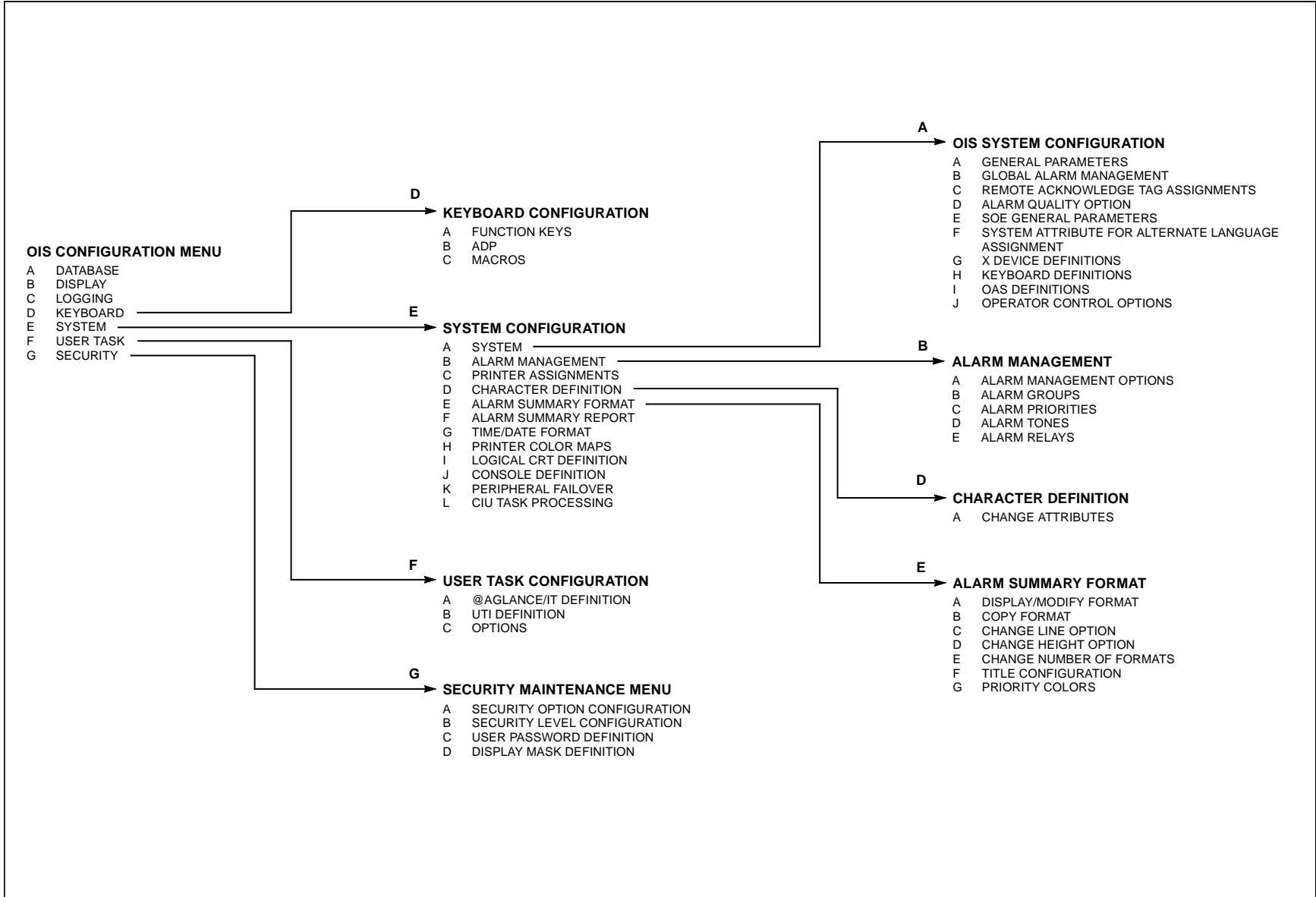

Figure 5-4. Menu Structure - OIS Configuration (2 of 2)

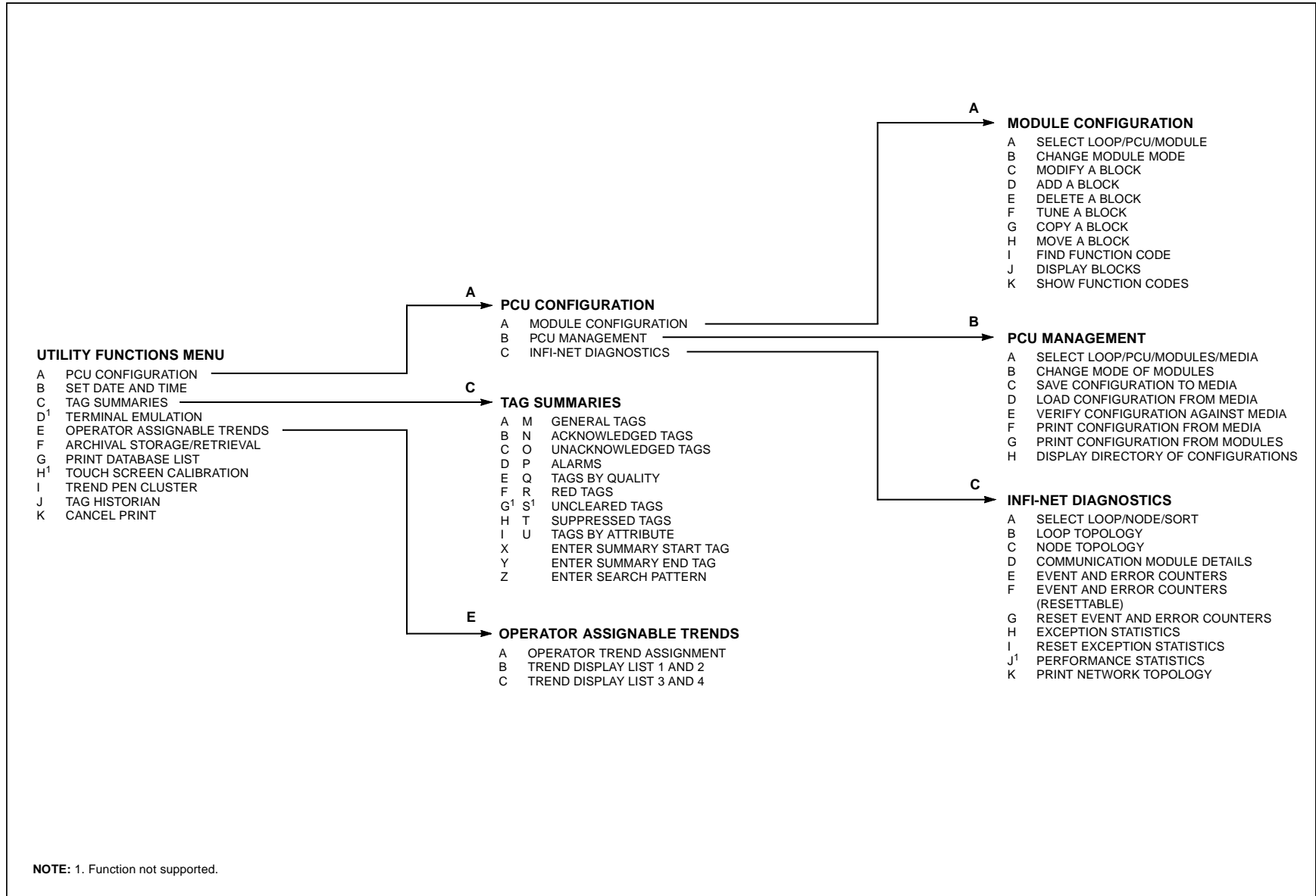

Figure 5-5. Menu Structure - OIS Utilities (1 of 3)

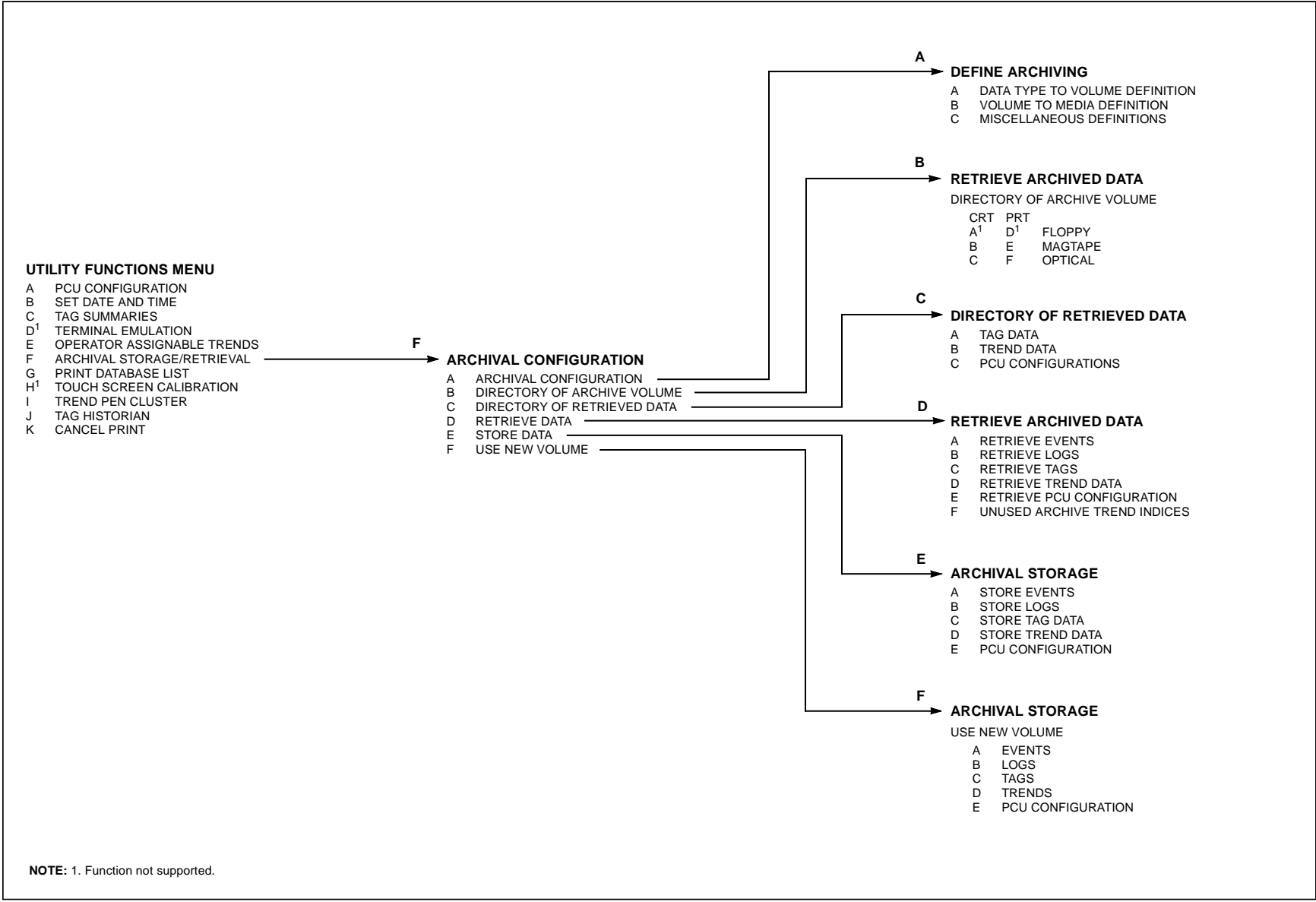

Figure 5-6. Menu Structure - OIS Utilities (2 of 3)

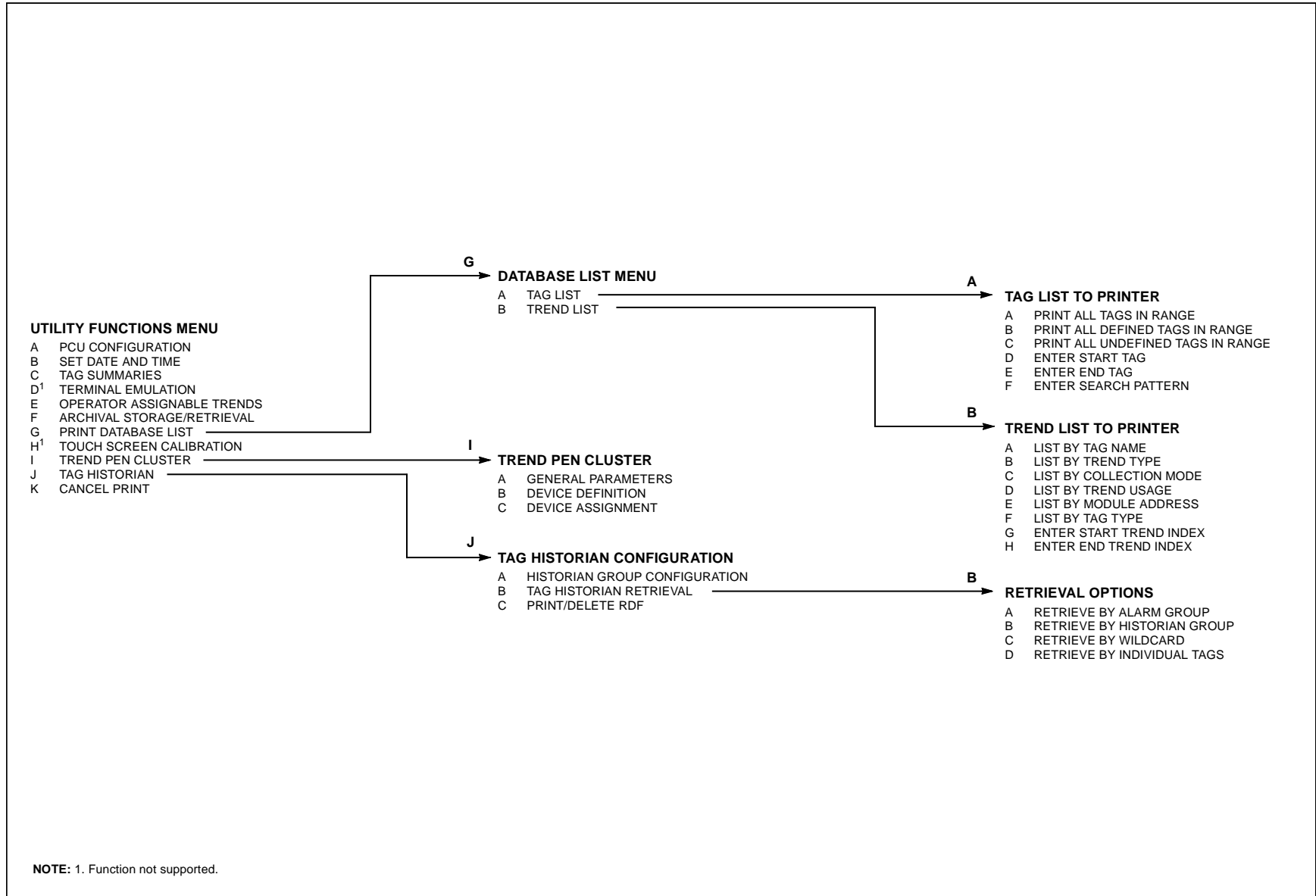

Figure 5-7. Menu Structure - OIS Utilities (3 of 3)

MISCELLANEOUS MENU

The miscellaneous menu provides access to the *Log Status*, *Log by Name*, and *Display by Name* functions. These are explained in later sections of the instruction. Press **MISC MENU** to access the *Miscellaneous Functions* menu (Figure 5-8).

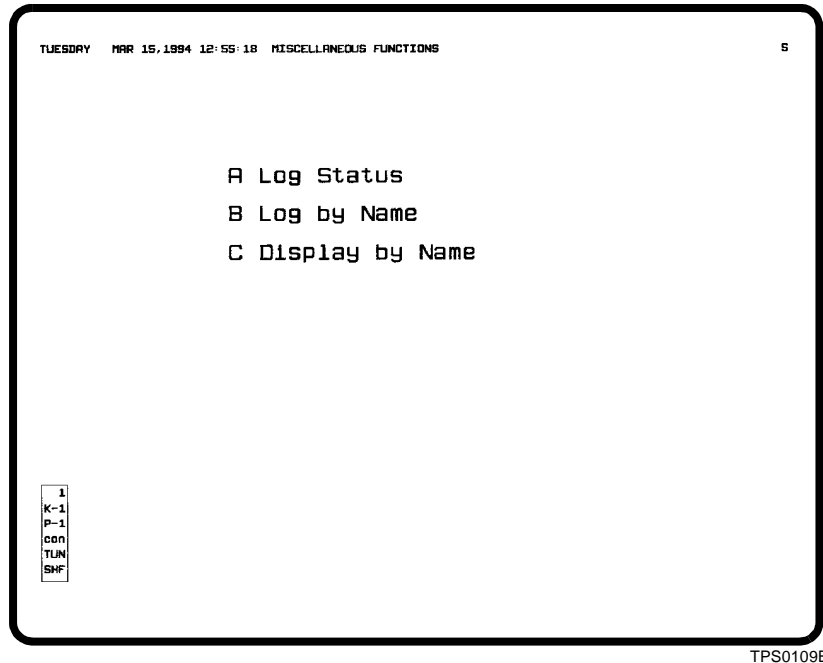

Figure 5-8. Miscellaneous Menu

COMMAND LINE MENU

The command line menu is a bottom line menu. Press **COM'D LINE MENU** to call the menu. The menu gives access to the following functions:

- A *CALC* - on-line calculator.
- B *NOTE* - note field for entering notes into the events log.
- C *ASGN PRN* - printer assignment function.
- D *PRINT* - initiates a screen print.
- E *LOG/NAME* - initiates a log printout.
- F *PASSWORD* - password log-in capability.
- G *LOG OUT* - password log-out capability.
- H *CRT OVRD* - redirects the next display call-up to another window.

SECTION 6 - WINDOWS SYSTEM

INTRODUCTION

The console display system directly employs the X library to generate graphic displays. The X library is a standard X Window System™ component. A MOTIF window manager provides the windowing environment in which displays operate. This section:

- Provides a brief description of the OIS application and OIS utilities that run on the console.
- Explains how to use the mouse.
- Summarizes key window features used in OIS application operation.
- Describes the operation of the OIS application and OIS utilities on IIOIC41 and IIOIC42 auxiliary consoles.
- Provides a brief description of session manager options.

OIS APPLICATION AND OIS UTILITIES

This instruction explains only the applications provided with the console that support INFI 90 OPEN process control and data acquisition. The primary application for this purpose is referred to as the **OIS application** in this instruction. Additional Elsasg Bailey created applications have been provided to enhance console operation and to support the primary OIS application. These utilities include:

- OIS activity monitor.
- OIS diagnostic log.
- Screen copy.
- Screen copy color map.
- Screen copy configuration.
- Touch pad configuration.
- Touch screen setup.
- Cursor configuration.
- Environment configuration.
- OIS menubar configuration.

The term **OIS utilities** is a general term used to refer to these applications. Refer to [Section 8](#) for an explanation of the individual utilities.

USING THE MOUSE

The mouse (or trackball) is an integral component of the windows system and console operation. The mouse pointer and mouse buttons initiate most screen operations. Placing the pointer over a display item and **clicking** (press and release) the appropriate mouse button initiates an action. Positioning the mouse pointer over a display item is also referred to as **pointing**.

Moving Between Screens

Move the mouse pointer vertically or horizontally until it disappears from one screen and reappears on the other to switch between the upper and lower screen of the console when it has dual screens.

Mouse Buttons

The mouse has three buttons designated MB1 (mouse button one), MB2, and MB3. MB1 is the left button, MB2 is the center button, and MB3 is the right button by default. The mouse is configurable as far as switching the MB1 and MB3 button locations. Also, the *X Device Definition* option allows selectively enabling or disabling a mouse button for use within the OIS application. Refer to the discussion on X device definition in the **Configuration** instruction for further explanation (Table 1-2 lists instruction numbers).

When operating in the OIS application, MB1 is mostly used. MB2 works the same as **ESC** on the operator keyboard. If desired, the button can be disabled with X device definition.

When told to **drag** the pointer, press and hold MB1. Then move the mouse to reposition the pointer.

The mouse provides the ability to assign a keyboard to a window. This is required to use the keyboard to perform the operations enabled in the window. Assigning the keyboard to a window is referred to as **setting input focus**. To set input focus for a window:

1. Place the mouse pointer anywhere in the window area except over a button. The buttons are located at the upper right and left corners of the window.
2. Click MB1.

WINDOW LAYOUT

The OIS windows support all standard MOTIF window operations. The OIS application does, however, have some

restrictions on certain operations due to specific operational requirements. The following sections explain the restrictions.

Figure 6-1 shows an example of the screen depicting the window items only. The primary components are the application windows and icons. The top of the screen is reserved for application icons by default. Each window has the same basic layout.

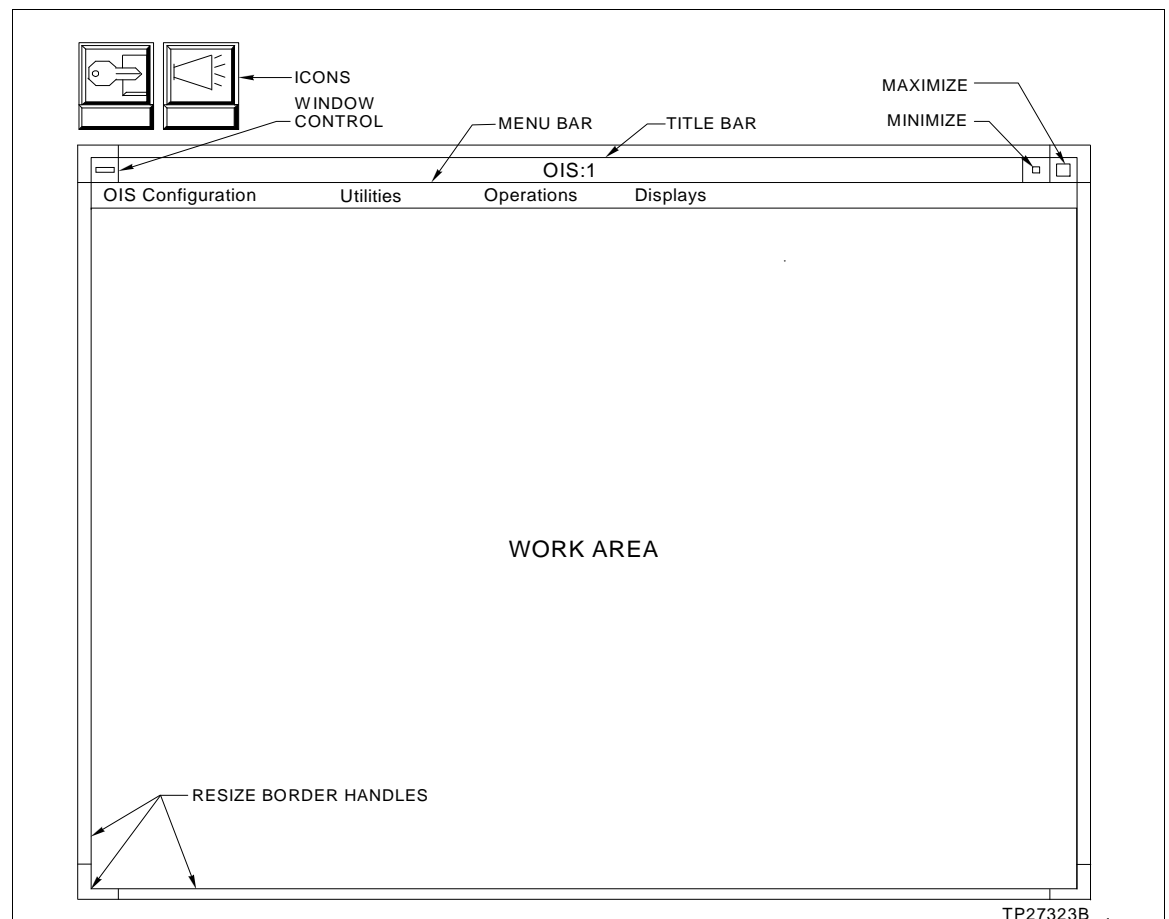

Figure 6-1. Window Overview

Title Bar

A title bar contains the application name and window control, maximize, and minimize buttons. Windows can be moved to other locations by using a built-in title bar feature. To **move** a window:

1. Place the mouse pointer anywhere in the title bar of the window to move except over a button.
2. Drag the window to a new location.

The title bar also allows moving a window from the top to the bottom of a stack of windows if windows are overlaying one another. To **push** a window to the back of a stack of windows:

1. Place the mouse pointer anywhere within the title bar of the window except over a button.
2. Double-click MB1.

Menu Bar

A menu bar lists the names of available pull-down menus. Not all windows have menu bars. Select a menu name to view its pull-down menu. An option, in a pull-down menu, is activated when selected. Some pull-down menu options have submenus associated with them, or cascade type menus. Choose options from these types of menus in the same way as any other types of menus.

Some pull-down menus have a tear-off capability. This capability is indicated by a dashed line that appears underneath the menu name. The pull-down menu is torn-off the menu bar by clicking on the dashed line and then dragging the menu to a new position on the screen. The tear-off menu is closed by first, clicking on the control button, located to the left of the menu name, in order to access the control menu, and then clicking on the close menu command.

The tear-off menu will remain and provide access to the commands listed when a window is pushed to the back of the stack. When a command is selected from a tear-off menu, whose associated window is located in the back of the stack, the associated window will automatically appear on the top of the stack. If a window is minimized, its associated tear-off menu is also minimized. When the window is restored, the tear-off menu is also restored to the location on the screen it occupied before it was minimized. When a window is closed, the associated tear-off menu is also closed. When the window is reopened, the tear-off menu does not reappear as it does when a window is minimized and then restored.

Both standard and custom menu bars are available.

The standard menu bar options in an OIS application window give access to the same functions that can be accessed from the general functions menu:

OIS Configuration - same as the *A OIS Configuration* option.

Utilities - same as the *B OIS Utilities* option.

Operations - same as the *C OIS Operation* option.

The standard menu bar also gives access to additional functions described in the following sections. Refer to [Section 5](#) for a tree structured view of the menu hierarchy.

The custom menu bar can include options that provide access to the same functions that can be accessed from the general functions menu, OIS displays, and custom menu options.

UTILITIES OPTION

In addition to the submenus of the *B OIS Utilities* hierarchy, the *Utilities* option of the menu bar gives access to:

Print Screen - works the same as the *D PRINT* option of **COM'D LINE MENU**.

OPERATIONS OPTION

In addition to the submenus of the *C OIS Operation* hierarchy, the *Operations* option of the menu bar gives access to:

Action - calls a display containing a ½-size operator action requests element and a ½-size operator information events element.

Log By Name - works the same as the *B Log by Name* option of **MISC MENU**.

Tuning Display - works the same as **TUNE**

Details - works the same as **DETAILS**

DISPLAYS OPTION

The *Displays* option of the menu bar gives access to a dynamic list of displays. The list contains the same displays as those that are assigned to the keyboard function keys. The list updates as function key assignments are changed. It also updates when keyboard to window assignments change.

In addition to the dynamic list of displays, the option also gives access to:

Alarm Summary - works the same as **ALARM SUMM**

Display Summary - works the same as **DISPLAY SUMM**

Help - works the same as **HELP**

Network Status - works the same as **SYSTEM STATUS SUMM**

NOTE: A display must be assigned to one of these keys for it to be available from the *Displays* option of the menu bar.

Display By Name - works the same as the *C Display by Name* option of **MISC MENU**.

Work Area

The work area is the primary display area of the window. This is where the OIS application operational displays and configuration pages appear. It is also the area where all process functions are performed.

Title Bar Buttons

Each window has buttons located at the upper right and left corners. The buttons are the window control, minimize, and maximize buttons.



Window control - gives access to the window control menu (e.g., minimize, maximize, size, etc.). Table 6-1 shows the window control menu items.

Table 6-1. Window Control Menu

Menu Item	Description
Restore	Restores the window to its size before minimizing or maximizing.
Move	Allows the window to be moved with keys or mouse.
Size	Allows the window to be resized.
Minimize	Changes the window to an icon.
Maximize	Expands the window to fill the screen.
Lower	Moves the window to bottom of a window stack.
Workspace	Contains different options depending on the console type.
Close	Terminates an application. This is not available in all windows.



Minimize button - shrinks a window to an icon to remove the window from the screen. This does not close the application and allows calling the application window back to the screen at any time. Click the button to minimize the window. When the icon is later expanded, the window restores to the previous screen location it occupied before being minimized.



Maximize button - used to resize a window to its maximum size. The button toggles between the maximum window size and a previous size.

NOTE: When a previously hidden portion of an OIS application window is exposed either by removing an overlaying window or expanding an icon, the window is redrawn. While working in an interactive page, such as the tag configuration page, the menu used to select the page is redrawn, not the page itself.

Icons

Icons are small graphic representations of windows. A window can be minimized to an icon by using its minimize button. An icon appears at the top of the screen by default to identify an application that is currently running. The icon disappears when an application is restored to a window or closed.

An application window can be called from an icon by double-clicking MB1 while on the icon. It can also be called by clicking MB1 once, then selecting *Restore* from the pull-down menu.

Resize Border Handles

The resize border handles are used to change the size of a window. To change the size:

1. Position the pointer over a resize border handle. The cursor changes shape when on a handle.
2. Drag the window border to a new size.

USING SHORTCUT KEYS

A limited number of screen operations can be initiated by pressing select keys on the auxiliary engineering keyboard. Operations, such as minimize, maximize, size, move, and close windows can be performed through combination of the mouse and the shortcut keys.

NOTES:

1. The mouse is required to select the window that the operations are to be performed upon.
2. The Auxiliary Engineering Keyboard is documented in [Appendix A](#).

Minimize a Window

To use the shortcut keys to minimize a window:

1. Use the mouse to select the window that is to be minimized to an icon.
2. Press the **ALT** and **F9** keys simultaneously.

Maximize a Window

To use the shortcut keys to maximize a window:

1. Use the mouse to select the window that is to be maximized.
2. Press the **ALT** and **F10** keys simultaneously.

Size a Window

To use the shortcut keys to size a window:

1. Use the mouse to select the window that is to be resized.
2. Press the **ALT** and **F8** keys simultaneously to activate the size command.
3. Press the appropriate cursor control key(s) to increase or decrease the size of the window. Both the width and length of a window can be adjusted.
4. Press the **RETURN** key when the window is adjusted to the desired size.

Move a Window

To use the shortcut keys to move a window:

1. Use the mouse to select the window that is to be moved.
2. Press the **ALT** and **F7** keys simultaneously to activate the move command.
3. Press the appropriate cursor control key(s) to move the window to a new position on the screen. The window can be moved up, sideways, or down on the screen.
4. Press the **RETURN** key when the window has been moved to the desired position on the screen.

Close a Window

To use the shortcut keys to close a window:

1. Use the mouse to select the window that is to be closed.
2. Press the **ALT** and **F4** keys simultaneously.

WORKSPACE MENU

Access to the *Workspace* menu is required to perform certain operations described in this instruction. Access can be gained in several ways.

To call the menu from the screen background:

1. Place the pointer anywhere in the screen background.
2. Click MB1 or MB3.

To call the menu from a window title bar:

1. Place the pointer anywhere in the title bar of a window except over a button.
2. Click MB3.
3. Select *Workspace*.

To call the menu from the window control menu:

1. Place the pointer over the window control button.
2. Click MB1.
3. Select *Workspace*.

Refer to **Mouse Buttons** in this section for a description of MB1 and MB3.

SIZING AN OIS APPLICATION WINDOW

The OIS application supports window resizing in discrete steps, not arbitrary sizes. The OIS application allows windows that vary in size by approximately one-inch increments in the vertical direction. On the standard 1280 × 1024 resolution screen of a 40 series console, eight discrete window sizes are supported ranging from ¼-screen to full size. Refer to **Resize Border Handles** in this section for the procedures to resize the OIS application window.

This type of window resizing was implemented so that displays remain consistent as windows are resized. Graphics can be resized to any size, but text is limited to available font sizes. The available window sizes maintain the relationship between graphic images and text from size to size.

AUXILIARY CONSOLES

A main console can operate with two different types of auxiliary consoles: IIOIC42 and IIOIC41. The IIOIC42 console

utilizes a TEKTRONIX[®] processor and the IIOIC41 console utilizes a DEC[™] processor. As a result there are some differences in operation between the IIOIC42 and IIOIC41 consoles.

The main difference between the two is that the IIOIC42 console uses an OIS session manager window instead of the DECwindows[™] session manager. The DECwindows session manager appears on all main and IIOIC41 auxiliary consoles. The OIS session manager is a representation of the DECwindows session manager. Its menus are similar to the DECwindows session manager menus and in most cases operate the same. Refer to **SESSION MANAGER** in this section for an explanation of the menu options.

In this instruction, **session manager** refers to either the OIS session manager or the DECwindows session manager. In general, the information given in this instruction applies to all types of main and auxiliary consoles except where noted.

IIOIC42 Console

The operation of an IIOIC42 auxiliary console is dependent on a main console (i.e., host node). The IIOIC42 console requires its main console to be running for **all** OIS applications and utilities. For example, if a main console is completely shut-down, the OIS application and all OIS utilities on the IIOIC42 console close including the session manager.

Since windows from more than one main console can appear on the IIOIC42 console, any windows from other main consoles that are not shutdown can still be used. An exception to this is if the main console generating the touch pad windows on the IIOIC42 console is shut down, then the touch pads will close.

Configuration changes made to OIS utilities from the IIOIC42 console directly affect the main console. For example, screen copy configuration changes made from the IIOIC42 console will be reflected on the main console. An OIS application start-up, shutdown, or reset from either the main or auxiliary console does not affect any OIS utilities on the IIOIC42 console, however.

For the most part, all OIS utilities available on the IIOIC42 console run the same as they do on the main console or any other type of auxiliary console.

OIS SESSION MANAGER START-UP

The OIS session manager does not automatically appear on the IIOIC42 console until after a host node has been identified. The IIOIC42 configuration procedure in the **File Utilities** instruction must be performed to identify the host node (Table 1-2 lists instruction numbers). Once configured, the host node is remembered and becomes the default host node

for the console. The host node can be any main console running H.2 or later software.

During start-up or after a reboot, the IIOIC42 console starts the windowing system and requests the session manager from the main console designated as its host node, then waits for the main console to send an OIS application window. The main console does not send an OIS application window to the IIOIC42 console until the window is activated. Refer to the discussion on window management in the **Configuration** instruction (Table 1-2 lists instruction numbers).

When a main console with an active session manager on an IIOIC42 console is completely shutdown, the session manager will automatically be restarted on the IIOIC42 console after the main console boots-up.

CALLING MULTIPLE SESSION MANAGERS

Unlike a main and IIOIC41 console, which only allow one session manager, multiple OIS session managers can be running on an IIOIC42 console. A main console can run a session manager on up to eight IIOIC42 consoles.

The main console cannot run two session managers on a single IIOIC42 console, however. For example, if a session manager from main console one is already running on this IIOIC42 console, another session manager from main console one cannot be requested.

Important

When running multiple session managers, care should be taken to insure that applications and utilities are not inadvertently run from the wrong session manager. The name of the host node is identified in the window title and also in the icon title.

To request the session manager from another main console:

1. Call the *Workspace* menu and select *Local Clients* then *HostMenu*.
2. Click *VMS TDEnet*.
3. Select a node name from the list. The node name must be a main console and must not already be running a session manager on this console.

After selection, the IIOIC42 console connects to the selected node and after a short while a session manager and message window will appear.

Multiple OIS utilities can run on an IIOIC42 console. For example, *Screen Copy Configuration* can be started from the

session manager of node one and also from the session manager of node two. Node one screen copy configuration will not affect node two screen copy configuration. The name of the host node for a utility is identified in the window title and also in the icon title.

To close a session manager, select *Close* from the window control menu. This also closes all other applications associated with the session manager.

IIOIC41 Console

The operation of an IIOIC41 auxiliary console is dependent on a main console. The IIOIC41 console depends on the main console for the OIS application and for some of its utilities such as the diagnostic log and activity monitor utilities. Other applications and utilities such as the message window and screen copy configuration do not need the main console to be running. If the main console is completely shutdown, only the OIS application and any dependent applications are affected on the IIOIC41 console.

Configuration changes made to OIS utilities from the IIOIC41 console do **not** affect the main console. Changes made to the OIS application, however, are reflected on the main console.

The session manager of an IIOIC41 console becomes active upon start-up independent of a main console. The IIOIC41 start-up consists of starting the windowing system and opening the session manager and message window. It then waits for the main console to send an OIS application window. The main console does not send an OIS application window to the IIOIC41 console until the window is activated. Refer to the discussion on window management in the **Configuration** instruction (Table 1-2 lists instruction numbers).

SESSION MANAGER

The session manager controls a windows session. The session manager can be opened by positioning the mouse pointer on the session manager icon and double-clicking MB1.

Applications The session manager *Applications* option gives access to the following applications:

Login Window - calls a terminal window (DECterm) to run various utilities and to execute system commands. Refer to **LOG-IN WINDOW** in Section 8 for an explanation.

Mail - gives access to network mail. Refer to **MAIL** in Section 8 for an explanation.

Message Window - calls the message window to view OIS related messages and operation communication messages (OPCOM). Refer to **MESSAGE WINDOW** in Section 8 for an explanation.

Bookreader - runs the Bookreader utility to view DEC documentation.

OIS Utilities

The session manager *OIS Utilities* option gives access to the following utilities:

Screen Copy - initiates a screen print. Refer to **SCREEN COPY** in Section 8 for an explanation.

OIS Diagnostic Log - starts the diagnostic log. Refer to the discussion on the diagnostic log in the **File Utilities** instruction for an explanation (Table 1-2 lists instruction numbers).

OIS Activity Monitor - starts the activity monitor. Refer to the discussion on the activity monitor in the **File Utilities** instruction for an explanation.

Abort Screen Copy - cancels the last queued screen copy request. Refer to **Canceling a Queued Screen Copy** in Section 8 for an explanation.

Screen Copy Color Map - configures color swapping for the print screen options. Refer to **Screen Copy Color Map Utility** in Section 8 for an explanation. Only one copy of the utility can run on either the main or IIOIC42 auxiliary console at a time.

Screen Copy Configuration - configures screen copy printers. Refer to **SCREEN COPY** in Section 8 for an explanation. Only one copy of the utility can run on either the main or IIOIC42 auxiliary console at a time.

Touchpad Configuration - configures touch pads. Refer to **TOUCH PAD** in Section 8 for an explanation. Only one copy of the utility can run on either the main or IIOIC42 auxiliary console at a time.

Touchscreen Setup - configures touch screen options and allows calibrating the touch screen. The *Touchscreen Setup* utility is only available on a main console or IIOIC41 auxiliary console. An IIOIC42 touch screen is calibrated using a different method. Refer to **TOUCH SCREEN** in Section 8 for an explanation.

Cursor Configuration - configures shape, foreground color and background color of the mouse cursor. Refer to **CONFIGURING THE MOUSE CURSOR** in Section 8 for an explanation.

Environment Configuration - configures functions and features of the OIS windows. Refer to **CONFIGURING THE OIS WINDOW ENVIRONMENT** in Section 8 for an explanation.

OIS Menubar Configuration - configures the contents of the menubar as well as the contents and hierarchal structure of associated menus. Refer to **CONFIGURING THE MENU BAR** in Section 8 for an explanation.

Startup/Shutdown The session manager *Startup/Shutdown* option gives access to *Abort Auto OIS*, *OIS Startup*, *OIS Shutdown*, and *OIS Reset*. These options affect the OIS application only. Refer to the general information section in the **Configuration** instruction for the procedures to start up, shutdown, and reset the OIS application, and for the procedures to abort the OIS application automatic start-up.

NOTE: The *Abort Auto OIS* option is not supported on the IIOIC41 auxiliary console.

Options The session manager *Options* selection allows changing the screen background and window colors, and saving the current session manager settings for a main console and IIOIC41 auxiliary console. These operations are explained in the DEC documentation. Use the *Save Settings* option on an IIOIC42 auxiliary console to save the location of the session manager and message window.

OPENING A WINDOW ON THE UPPER SCREEN

The session manager has options that when selected open a window. To open a window on an upper screen:

1. Click the ellipsis (. . .) next to a menu option. This opens a *Qualifiers* window.
2. Enter **1** as the *Screen* number to specify the upper screen.
3. Click *OK*. After a short while, the window will appear on the upper screen.

SECTION 7 - GENERAL OPERATIONS

INTRODUCTION

This section explains basic operations for the console including:

- Security password log-in and log-out.
- Data input.
- Accessing displays.
- Display and control select options.
- Calculator.
- Note (event log).

OPERATING THE OIS APPLICATION

1. Start up the OIS application if it is not already running. Refer to the general information section in the **Configuration** instruction for the procedures to start up the OIS application (Table 1-2 lists instruction numbers).
2. After start-up, check if there is a flashing *A* at the upper right corner of the window. The *A* indicates an operator action is required. Use the *Operator Action Requests* option to view an action request. If the following message appears as an operator request for action, use the *Set Date and Time* option to set Greenwich Mean Time (GMT).

GREENWICH MEAN TIME MUST BE INITIALIZED

Refer to **OPERATOR ACTION REQUESTS** in Section 17 for information about operator action requests. Refer to **SET DATE AND TIME** in Section 20 for information on how to set GMT time.

3. Log in a password. Refer to **SECURITY PASSWORD** in this section for the procedures.

KEY LOCK

IIOIS42 and IIOIS43

For the IIOIS42 and IIOIS43 consoles, the TUNE/CONFIG key lock is used to limit access to tuning and configuration functions. The only way to change the key lock position is to insert a key and turn. After changing the switch position, remove the key. This locks the key switch in its current position.

To access configuration functions, put the key lock in the CONFIG position. To access tuning functions, put the key lock in the TUNE position. Switching the key lock back to the LOCK position before saving any modifications discards any and all modifications.

IS42 and IS43 The IS42 and IS43 consoles do not have a TUNE/CONFIG key lock. Instead, the same functionality is handled with passwords. Password security is configured with default passwords that control the key lock functionality BOTHLOCK, CFGLCK, NOLOCK, and TUNLCK.

The NOLOCK password disables the CONFIG/TUNE key lock functionality. The CFGLCK password disables the CONFIG key lock, but leaves the TUNE key lock enabled. Use this password to configure the OIS application. In this case, no tuning or access to functions that require tuning access rights will be allowed. The TUNLCK password disables the TUNE key lock, but leaves the CONFIG key lock enabled. Use this password to access tuning functions. In this case, no OIS application configuration will be allowed.

If the key lock is not in the correct position when attempting to access a certain function, or in the case of the Signature Series Work Station the correct password is not logged in, the following prompt appears:

Function under TUNE Keylock Control

- or -

Function under CONFIG Keylock Control

Password security configuration can be used to enable or disable the key lock. If desired, passwords can be created to disable key lock functionality entirely.

SECURITY PASSWORD

The operations that can be performed within the OIS application depend on the key lock position and password security if implemented. A default user is automatically logged in during start-up. The user that is logged in depends on password security configuration.

Log-In

A password must be logged in to gain access to OIS application functions. The operations that can be performed and the configurations that can be accessed by a user depend on password security configuration. To log in:

1. Press **COM'D LINE MENU**.
2. Press **F** to select the *PASSWORD* option. A field with all asterisks appears.
3. Enter a valid password. Passwords are defined during password security configuration. If site specific passwords

have not been defined, use a default password OPERATOR, BOTHLOCK, CFGLOCK, NOLOCK, TUNLCK, or MAINT.

NOTE: The BOTHLOCK, CFGLOCK, NOLOCK, and TUNLCK passwords are not available on IIOIS42 and IIOIS43 consoles. They are used for IS42 and IS43 consoles which do not have a key lock.

By default, the OPERATOR password gives access to all functions except security maintenance and enables the key lock. The MAINT password denies access to all functions except security maintenance and disables the key lock.

For an Signature Series Work Station, the NOLOCK password is the same as the OPERATOR password except it disables the CONFIG/TUNE key lock functionality. The BOTHLOCK password works the same as the OPERATOR password. Use either password to deny access to all functions that require tuning and configuration access. The TUNLCK password is similar to OPERATOR except it enables the CONFIG key lock and disables the TUNE key lock. Use this to access all functions that require tuning access. The CFGLOCK password is also similar to OPERATOR except it disables the CONFIG key lock and enables the TUNE key lock. Use this to access all functions that require configuration access.

4. Press **ENTER**. The user is prompted if an invalid password was entered.

The top field in the keyboard status block at the lower left corner of the window identifies the index number of the currently logged in user. If the log-in is accepted, the field updates to the identification number of the user logging in. If the security level does not give access to the current window, the user cannot log in. A password log-in is recorded in the event log (or operator actions log).

A new password can be entered at any time without having to log out the current user. Repeat the log-in procedure to enter the password of another user. An option of password security can be enabled to automatically log a user off the system and log in a default user when the OIS application is inactive for a certain period of time.

A password log-in remains in effect until changed by entering another password or by an automatic log-out. To prevent unauthorized personnel from using the current access rights, log out before leaving.

Log-Out

A log-out cancels the current password access rights and logs in the default user. To log out:

1. Press **COM'D LINE MENU**.

2. Press **G** to select the *LOG OUT* option. As soon as it is selected, the user index number in the keyboard status block updates to the default user's index number.

NOTE: If the OIS application is reset, it comes back on-line with the access rights of the last entered user. The default user is logged in after a complete shutdown and power up.

DATA INPUT

In general, two types of input fields are used. One type has a limited number of permissible entries. For example, each tag type is distinct and variations are not allowed when inputting a tag type. The other type of field accepts an indeterminate input. For example, a name field accepts any alphanumeric character string up to the maximum characters allowed by the field.

Making a Field Active

For configuration pages, the input cursor appears at the upper left most input field after calling the page. The active input field always appears highlighted in reverse video.

Table 7-1 shows the keys used to move the input cursor and activate a field for entering data.

Table 7-1. Cursor Tabbing Keys

Key ¹	Function
	Moves the input cursor to the next logical input field as determined by the console. If there is an error, the cursor stays on the input field in error and an error message appears. In most cases, tabbing also enters data for the field from which the cursor was tabbed.
	Performs the same functions as TAB but moves to the previous logical input field.
	Moves the input cursor one field in the direction of the arrow. Use these keys to randomly move about a display.
	Moves the cursor within an input field one position in the direction of the arrow.

NOTE:

1. These keys are all located in the cursor and trend control block of the keyboard. Refer to **KEY-BOARD LAYOUT** in Section 3 for the location.

Inputting Data

As mentioned previously, an input field accepts either a limited number of choices or it accepts an indeterminate entry. Each input field is as long as the maximum number of characters allowed as input to the field. An input field is highlighted (reverse video) when active. Move the cursor within an active field and edit characters of the field by using the cursor control keys. In either type of field, a new entry can be made by simply typing the entry.

An input field operates in two ways:

- If the first key pressed is an alphanumeric key, it is assumed the current information is to be replaced. Any characters in the field clear and the entered character becomes the first character of the new entry.
- If the cursor within the field is moved from the first character position, it is assumed the field is to be edited and the current entry is not cleared. The field then operates in character replace mode.

To edit the ***first character*** in an input field without clearing the field, move the cursor within the field right one space then left one space.

For those fields that accept only specific, predefined entries, only enough of the entry is required to allow distinguishing it from other possible entries. For example, a field is to be defined with an RMCB tag type. Keying in **RMC**, then either pressing **ENTER** or moving the input cursor away from the field is enough to determine that the input is to be RMCB. This works for most input fields of this type.

Input Field Error Checking

Error checking is performed on input fields. If an entry is invalid, it is not possible to leave the input field until correcting the entry or resetting it to its original entry. **HOME** resets the current field to the text string it held when the display was first called. Press **HOME** while on a field, but before moving to the next field or pressing any other key to reset a field.

Entering Alternate Language Characters

The console can be configured for alternate language. Three types of character sets are supported ASCII, extended, and complex. The ASCII character set is the default set. This set supports English characters entered by using the standard console keyboards.

Configuration page fields allow input from an alternate language keyboard or a standard keyboard. File names, display names, and numeric value fields require ASCII (English) characters only.

EXTENDED CHARACTERS

An extended alternate language character set allows for up to 256 individual characters. For most languages, the first 128 characters are English characters and any additional alternate language characters are contained in the upper 128 characters. For others, all or most of the 256 characters are used for the alternate language and the English characters reside in a separate character set. Most alternate languages can be supported with an extended character set.

The number of characters required for a particular language determines the keyboard layout. For some languages, the keyboard has the 26 English language character keys and any additional keys required for the language. For other languages, the keyboard has both an English character and an alternate language character on a single key. An alternate language shift key (**ALT LOCK**) either enables the additional character keys of the language or toggles between alternate language character entry and English character entry.

Besides a keyboard that contains the alternate language characters, a printer that supports the alternate language characters is also required to correctly print text. Refer to the supplemental documentation provided with an alternate language kit for further explanation of the requirements for a particular language.

COMPLEX CHARACTERS

The complex set is for alternate languages that use numerous and intricate characters. Two methods of complex character input are supported: Serial input and Romanization.

Serial input requires a serial input device or a personal computer that inputs the complex characters as standard encoded values, which consist of two bytes per character. Using character Romanization, ASCII character key presses are translated into complex encoded characters.

A printer that supports the alternate language characters is also required to correctly print text. Refer to the supplemental documentation provided with an alternate language kit for a description of complex character input procedures and for further explanation of the requirements for a particular language.

ACCESSING DISPLAYS

Several different types of displays are used to convey process information. The displays must be accessed by some means to view the information. Displays can be called directly by keyboard function keys, or can be called by key or touch point selects built into user-created graphics. Another option is to have display or pop up elements appear automatically based on process events.

Menu Items

Menus can be designed into any graphic. The menu options are built into the graphic as interactive display selects. These built-in selects can be used to directly access a particular display by pressing a key sequence or by touch point.

Display Summary

An option available for display call-up is to create a graphic that lists all system displays and incorporates built-in selects for each display listed. This display can be assigned to **DISPLAY SUMM** for easy access. In this way, **DISPLAY SUMM** can be pressed to call the display list, then an alphanumeric key or a touch point can be pressed to call a specific display from the list.

Keyboard and Annunciator Display Panel Access

Displays can be called directly using:

- Assignable function keys.
- Display control keys.
- Annunciator display panel (ADP) pushbuttons.

NOTE: A key macro assigned to a function key or pushbutton should **not** be activated from a display that has an element selected for control. Deactivate control before activating the macro.

During configuration, displays can be assigned to function keys. After being assigned, pressing a function key calls a display directly. A display can be called by function key at any time.

Displays can also be assigned to annunciator display panel pushbuttons. These pushbuttons are normally used for alarm processing. After being assigned, pressing a pushbutton calls a display directly. A display can be called by pushbutton at any time. Refer to **ANNUNCIATOR DISPLAY PANEL** in Section 3 for an explanation of ADP operation.

Pressing an ADP pushbutton or function key that does not currently have a display assigned calls a default blank display (**BLANK.DU**). The default can be changed by performing annunciator display panel or keyboard configuration.

Display by Name Access

A *Display by Name* option allows calling any display by its name. This option requires knowing and entering the name of a display. The name that is entered must be of an assembled display file (**DU**) or of an operator configurable display. To call a display by its name:

1. Press **MISC MENU**. A full page menu appears.
2. Press **C** to select *Display by Name*. A *Display Name* field appears.
3. Enter the name of a display file without its extension. For example, to call a display defined in a file called **AREA1.DU**, enter:

AREA1 **ENTER**

If a display file (or operator configurable display) with the entered name does not exist, the following message appears:

Display Not Found

Automatic Displays or Pop Up Elements

Displays can be defined as automatics. An automatic display will appear in place of the current display when activated. Pop up elements can also be defined as automatics. An automatic pop up will appear on the current display at a specified location when activated. A set of DIGITAL tags are monitored to trigger the automatic activation of these displays or pop up elements. This allows automatic display activation based on process changes.

Automatic displays and pop ups are configured in sets. Each set contains a list of tags, and each tag in a set has a display (**DU**) or pop up element (**DL**) assigned.

The triggering of an automatic display or pop up occurs when a DIGITAL tag in the currently active set changes from its zero state to its one state. This requires, however, that there is no previously triggered display or pop up and the DIGITAL tag that triggered the last display or pop up has returned to its zero state.

Any automatically triggered display or pop up operates as normal when it appears. Any display or pop up designated for

automatic display can be called in the normal methods described previously.

ACTIVATING AN AUTOMATIC DISPLAY SET

During configuration, a master display is assigned to an automatic display set. To activate a display set, call its master display. Either the operator or automatic display function can do this. The tags defined in the set are monitored to trigger the automatic display function.

Normally, a denotation symbol is assigned to a display set and appears to identify a display or pop up call-up as an automatic call-up. The denotation symbol does not appear for any display or pop up that is called manually using any method previously described.

DEACTIVATING AN AUTOMATIC DISPLAY SET

During configuration, a termination display is assigned to an automatic display set. A display set remains active until the operator or automatic display function calls its termination display or another display set is made active. The currently active display set is also deactivated when a display (not a pop up) that is not a master display is manually called. The display being called can be part of an automatic display set as long as it is not a master display. The tags of a display set are no longer monitored once the display set is deactivated.

To reactivate the previously active set, either call its master display or call the last display triggered by the set.

User Task Activated

A user task interface gives the ability to write a program and have it executed by the console. This program can call displays during its execution. Depending on console and display configuration, a program can be executed by pressing a function key or ADP pushbutton or by touch point.

By default, a user task display activation must be acknowledged before a display is called. This requirement, however, can be disabled. If disabled, an activated display immediately replaces the current display with no prior notification.

If left enabled, a dialog box appears and identifies where a display call-up will occur. The dialog box only appears after a user task activates a display call-up. The title bar of the dialog box shows the following text:

UTI Display Request for xxxx n

where:

<i>xxxx</i>	OIS client name entered during <i>X Device Definition</i> .
<i>n</i>	Window number.

Input focus is not automatically set to the dialog box when it appears.

The box also contains some dialog generated by the program and two control buttons. The control buttons allow accepting (i.e., *DISPLAY*) or rejecting (i.e., *IGNORE*) the display call-up.

A time-out parameter in the user-written program can be used to automatically initiate a rejection of a display call-up. An automatic rejection occurs when there is no response to a call-up request within a specified amount of time. If enabled, the call-up request must be responded to promptly before the dialog box disappears. Unless the program is written specifically to initiate the call-up of the rejected display again immediately after a time-out, the dialog box will not reappear until the program is executed again. The time-out can also be set to zero to have the program wait for a response indefinitely.

To respond to a display call-up:

1. Set input focus to the dialog box by placing the mouse pointer in the box and clicking MB1.
2. Click *DISPLAY* to accept the display call-up or click *IGNORE* to reject the display call-up.

If accepted, the dialog box disappears and a display appears in the indicated window replacing any current display in that window. If the window is currently shrunk to an icon, the window is automatically opened. The dialog box disappears and a new display does not appear if a call-up is rejected.

NOTE: It is suggested that all dialog boxes be cleared before shutting down or resetting the OIS application.

Redirecting a Display Call-Up

In certain instances, it may be desired to temporarily redirect a display call-up to another window. The ability to send the next display called from the current window to any other window is provided. This is a one-shot override. Subsequent display requests from the current window resume on the default, current, or configured window as normal.

To redirect a display call-up:

1. Press **COM'D LINE MENU**.
2. Press **H** to select *H CRT OVRD*. The following prompt appears:

CRT Ovrđ to n, enter crt or 0 to cancel

The *n* portion of the message shows the number of the window that is currently the override window. A *0* indicates that there is currently no override.

3. Enter the number of a window to which to direct the next display call-up. A valid entry is from 1 to 8. Enter **0** to cancel and exit. The following prompt appears to indicate where the next call-up will occur:

CRT Ovrđ assigned to n

The *n* portion of the message should indicate the number of the window selected in this step.

To cancel a previous override:

1. Press **COM'D LINE MENU**.
2. Press **H** to select *H CRT OVRD*. The following prompt appears:

CRT Ovrđ to n, enter crt or 0 to cancel

3. Enter **0**. The following prompt appears to indicate that the override has been canceled:

CRT Ovrđ has been disabled

NOTE: An override affects only the first display in a multiwindow display list.

Display Paging

The keyboard provides several keys used to move between pages and displays. When a desired display is on the screen, the normal operations related to that display can be performed.

BACK AND FORWARD KEYS

BACK and **FORWD** recall the last six displays previously viewed.

To use **BACK**:

1. Press **BACK** to call the display that was on the screen previous to the current display.
2. Continue to press the key to sequence backwards through additional displays until eventually returning to the current display.

To use **FORWD**:

1. Press **FORWD** to call the last of six previous displays.
2. Continue to press the key to sequence forward through additional displays until eventually returning to the current display.

MARK AND RECALL KEYS

MARK and **RECALL** provide a bookmark function. A display can be marked to recall it at any time in the future. Up to ten different displays can be marked for eventual recall.

To mark a display:

1. Press **MARK**. An *Enter display number to MARK* prompt appears.
2. Press any number key from **0** to **9**. This becomes the number that must be entered to recall the display.

To recall a display:

1. Press **RECALL**. An *Enter display number to RECALL* prompt appears.
2. Press the number key previously selected with the mark function.

NEXT PAGE AND PREVIOUS PAGE KEYS

NEXT PAGE and **PREV PAGE** function only for certain pages. As a general rule, a function identifies the requirement for using these keys by either presenting *NEXT PAGE* or *PREV PAGE* text or a *Page n of n* field. These keys can be incorporated as inter-actives in any user-created graphic.

DISPLAY AND CONTROL SELECT OPTIONS

The keyboard is the main operator input device for the console. The keyboard, described earlier in [Section 3](#), provides the display and control element select, data input, and process control capabilities.

The touch screen, mouse, and trackball provide an alternate method of selecting display items instead of from the keyboard. These options are available for selecting displays or activating control. However, the actual control actions can only be initiated from the keyboard or a touch pad. Also, data input can only be performed by using the keyboard or a touch pad. Any active element can be deactivated by pressing **ESC**

Any display can be created to use key selects, touch points (touch screen, mouse, and trackball), or both. A key select is any single alpha character or a two-alphanumeric character combination. The single character requires only a single key press for selection. The two-character combination requires pressing a two-key sequence. A touch point is a designated area on the screen that initiates a display select or activates control when pressed or when the mouse pointer is positioned over it. The types of select options incorporated into a display are determined during its creation.

NOTE: Standard displays and menus have touch points already designated in their configuration, which allows using the touch screen, mouse, and trackball options.

Touch Screen

A touch screen option uses pressure-sensitive touch screen technology to select display items. This option enables selecting a tag for control or calling another display by touching an area on the screen. When a touch point is pressed, a short audible tone can be heard from the keyboard. Touch point escape codes must be configured during display creation before touch screen select can be used for a particular display.

Mouse or Trackball

A mouse or trackball is useful to quickly move about a display. The trackball works the same as a mouse. A mouse or trackball is required to operate the console. Any display item with a defined display or control select touch point can be selected by placing the mouse or trackball pointer over the touch point. Refer to **USING THE MOUSE** in Section 6 for additional explanation.

The trackball operates in two different speeds: normal and slow. Initially, the cursor moves in the normal speed. Press the speed change button located below the activation buttons to toggle between normal and slow speed. In slow speed, it takes four times as much movement of the ball to produce the same cursor movement as the normal speed.

Control Select Highlighting

To verify selection or identify a display element as being in active mode, outline or border highlighting is used. A change in the outline of an element from a normal to a highlight color provides a visual verification of selection. Standard highlighting changes an outline color from blue to cyan when used against a black background. Used with other background colors gives different results. The highlighting feature applies to elements such as alarm summary, faceplate, and trend elements.

An option available is to have a touch area border highlight when selected. This option is similar to outline highlighting that occurs when making a keyboard selection. Touch point highlighting is enabled by entering **YES** in the *Highlight Selected Touch Area* field on the general parameters page during system configuration. After enabling the option, the outer border of a designated touch area highlights when selected.

A border highlight, whether initiated by key or touch point selection, remains on the display until:

- Touching another touch point.
- Selecting another touch point with the mouse or trackball.
- Initiating a selection by using the keyboard.
- Calling a new display.
- Pressing **ESC**.

For example, after calling a group display, a single faceplate can be enabled for control by key selection, by touching it, or by using the mouse or trackball. The border of the selected faceplate then highlights (changes to cyan) to identify the element as active. After activating a faceplate, process control can be initiated by performing certain keyboard actions. Selecting another element causes the previously selected element to return to its normal color and condition. Control for the previously selected element also disables. Only one element can be selected for control at a time.

Pop Up Control

Any display can be designed to incorporate pop up elements. Standard pop up faceplate symbols are provided for DANG, DD, MSDD, RCM, RMCB, RMSC, and STATION tags.

After being selected, a pop up element comes up in the active control mode. Device control can be initiated from the keyboard or a touch pad. Control actions permitted are dependent on the type of element.

Deactivate pop up control by pressing **ESC**. The element remains on the display and can be activated again by using key or touch point select.

CALCULATOR

The command line menu *CALC* option provides an on-line, four-function calculator to perform addition (+), subtraction (-), multiplication (*), or division (/). To use the calculator:

1. Press **COM'D LINE MENU**.
2. Press **A** to select *A CALC*. An input field appears at the bottom of the window. The field allows entering calculations by using the operators available in the numeric keypad.
3. Type in the calculation. For example, to multiply 15 by 25, type:

15*25

4. Press **=** after keying in the calculation to see the result of the calculation.
5. Press **ESC** to remove the calculator field.

NOTE

The command line menu *NOTE* option gives the ability to enter a note into the system event log. To enter a note:

1. Press **COM'D LINE MENU**.
2. Press **B** to select *B NOTE*. An input field appears at the bottom of the window.
3. Type in a note of up to 80 characters.
4. Press **ENTER**.

SECTION 8 - WINDOWS APPLICATIONS AND UTILITIES

INTRODUCTION

This section explains the message window, mail, and log-in window applications and the following utilities:

- Abort screen copy.
- Screen copy.
- Screen copy color map.
- Screen copy configuration.
- Touch pad configuration.
- Touch screen setup.
- Mouse cursor configuration.
- OIS window configuration.
- OIS menu bar - submenu configuration.

The message window application is opened during initial console start-up. All other applications and utilities are run from session manager options. Refer to **SESSION MANAGER** in Section 6 for an explanation of the session manager.

MESSAGE WINDOW

The message window presents OIS related messages such as start-up, shutdown, and reset messages. It also presents network related messages.

NOTE: The message window on the IIOIC42 auxiliary console only presents OIS related messages. Network related messages do not appear.

The message window becomes available after console start-up. If the message window application has been closed, it can be opened again from the session manager. To run the message window application:

1. From the session manager, choose *Applications*.
2. Choose *Message Window*.

When a message is received, the system sounds a tone to inform the operator. Open the message window to view any messages. Messages are not lost if the window is changed to an icon or overlaid.

Various network conditions can cause the generation of operation communication (OPCOM) messages. These are often seen when the network is first being configured. They also can be generated by the network system manager and provide

information relating to network shutdowns or other network events.

MAIL

When sending mail to a main console, send it to the OISOPER user. When sending mail to an IIOIC41 console, send it to the SLAVE user. Mail cannot be sent directly to an IIOIC42 console. Instead, send it to a main console that has a session manager running on the IIOIC42 console.

LOG-IN WINDOW

A terminal window (DECTerm) is needed to perform operations such as running utilities and executing system commands. Also, an application can be run by typing the appropriate command at the dollar sign (\$) prompt of a terminal window. The session manager provides a *Login Window* option used to open a terminal window and log into an account.

To open a terminal window:

1. From the session manager, choose *Applications*.
2. Choose *Login Window*. After a short time, a window appears.
3. Set input focus to the window.
4. Type the name of an account in the *Username* field, then press **Return**. Normally, **OISENGR** or **SYSTEM** would be used for a main console and IIOIC42 auxiliary console, and **SYSTEM** for an IIOIC41 auxiliary console. Refer to the **File Utilities** instruction for a description of OIS accounts.
5. Type a password in the *Password* field, then press **Return**. The password does not appear. After a short time, the dollar sign (\$) prompt will appear.

To log into a different account from the current terminal window, type the following to call the *Username* and *Password* input fields:

SET HOST 0 **Return**

To close a terminal window:

1. If not already open, open the window.
2. Type:

LO **Return**

SCREEN COPY

Two methods for initiating a screen copy are provided: Command line menu *PRINT* option and pull-down menu *Screen Copy* option. The *PRINT* option is accessed from within the OIS application. This option can only be used to print the contents of an OIS application window. The *Screen Copy* option is accessed from the *OIS Utilities* pull-down menu and allows printing any window including an OIS application window.

The primary difference between the two methods is that the *PRINT* option freezes the blinking attributes of the OIS application window so they can be captured for printing. This method is recommended if the blinking items are important to the copy. The *Screen Copy* option does not freeze the blinking attributes and depending on timing may or may not capture any blinking attributes.

Screen Copy Printers

A printout using either screen copy method can be directed to one of up to four network printers connected at terminal servers. The printers available for screen printing are different and completely separate from those used to print logs and reports generated by the OIS application. The screen copy function currently supports the following types of printers:

- DEC LJ250 (IIPRT06).
- DEC LF01 (IIPRT07).
- DEClaser 2150 with PostScript™ option only.
- HP Deskjet 550C (IIPRT08).
- HP Deskjet 560C (IIPRT08A).
- HP LaserJet III with PostScript option only.
- HP PaintJet XL300.
- Laser printers that use HP PCL-5 control language.
- Lexmark 4079 plus color jet with PostScript option only.

Refer to the **Hardware** instruction for information on printer connection and cabling (Table 1-2 lists instruction numbers). Before a screen copy can be initiated, a printer must be configured and selected.

Print Node

The print node is the node responsible for printer configuration, capture of a window, and directing the image to the print queue manager. By default, the print node for an OIS application window is the node that generates the window. X device definition can be used to identify another node as the print node for a particular OIS application window. This allows off-loading the print node work to another node. The assignment affects printing initiated with the command line menu *PRINT* option only. The session manager is always the print

node when using the *Screen Copy* option of the *OIS Utilities* pull-down menu. For an IIOIC42 console, this is the main console.

A print node can be selected on a per window basis. Any console running the screen copy utility, except an IIOIC42 console, can be a print node. Refer to the discussion on window management in the **Configuration** instruction for a description of X device definition (Table 1-2 lists instruction numbers).

Screen Copy Configuration Utility

Selection and configuration of a printer are performed by using the screen copy configuration utility. The printer selected with the utility will be used for printouts initiated with either the command line menu *PRINT* option or the *Screen Copy* option of the *OIS Utilities* pull-down menu. Run the utility to:

- View the current printer settings.
- Select a printer.
- Configure a printer.

NOTE: The screen copy configuration utility does not have to be running to initiate a screen copy.

To run the screen copy configuration utility:

1. From the session manager, choose *OIS Utilities*.
2. Choose *Screen Copy Configuration*.

Any non-fatal errors encountered during screen copy configuration appear as messages at the bottom of the utility window. A fatal error appears in a dialog box. The only fatal error is not being able to communicate with the screen copy task.

Buttons Click *Apply* after configuring and selecting a printer. This saves the information.

Click *Reset* to restore the previously saved printer configuration and selection.

Click *Exit* to exit the utility.

NOTE: In the screen copy configuration utility, a depressed button indicates enabled. A raised button indicates disabled.

Selecting a Printer

A screen copy can be directed to one of four printers. To select a printer to receive a print job:

1. Open the screen copy configuration window. If a printer has not been configured, perform the steps given in **Configuring a Printer** in this section before continuing.
2. Choose a printer from the list of configured printers at the top of the window.
3. Click *Apply* to enable the selection.

Click *Reset* before *Apply* to cancel the printer selection and restore the previous printer selection.

4. Click *Exit* to exit the utility.

Configuring a Printer

Before printing a screen, a printer must be configured. Four different configurations can be defined. A few different methods can be used to configure the printers. The following paragraphs describe two methods.

Method 1 In a system having four different printers on the network available for screen printing, each configuration can be for a specific printer. This allows selecting to which of the four to send a print job. Each printer can be of the same type or of different types.

Method 2 For a system with only one printer for screen printing, each configuration can be set up with different print attributes. In this case, the single printer can be configured four different ways. Each setup is dependent on the type of screen printing to be performed. For example, the printer can be set up for gray scale printing in one configuration and color printing in another. This allows easily switching between the two print modes without having to reconfigure the printer.

To configure a printer:

1. Open the screen copy configuration window.
2. Select a printer to configure from the list of printers at the top of the window (either a previously configured printer or an unconfigured printer).
3. Enter a name for the printer configuration in the *Configuration Name* field. The name should be meaningful since it is also the text that appears at the top of the window to identify this

printer. The name should be descriptive enough to easily identify the printer and its configuration. For example:

HP 560C - B&W

4. Select a queue name from the *Queue Name* list. This is used to direct a printout to a specific printer (primary printer). The queue name is the name assigned to a printer during network configuration. Refer to **QUEUE NAME** in this section for further explanation.

5. Select a printer type from the *Printer Type* list.

NOTE: An HP LaserJet III with a PostScript cartridge installed, a DEClaser 2150 or a Lexmark 4079 plus can be used for screen printing if desired. Choose the DEC LF01 printer type when using either of these printers.

6. Select a queue name from the *Backup Queue Name* list. In this case, the queue name selects a backup printer rather than a primary printer. Refer to **SCREEN COPY PRINTER FAILOVER** in this section for an explanation of a backup printer.

7. Enter the number of copies to print in the *Copies* field.

8. Select the paper size from the *Paper Size* list if the printer type is HP PaintJet XL300.

9. Set the print attributes. The print attributes are the orientation, color swap, window border, and color mapping options. Refer to **PRINT ATTRIBUTES** in this section for an explanation of these settings.

10. Set the *Discard Prints when Dead-End Encountered* option. Refer to **SCREEN COPY PRINTER FAILOVER** in this section for an explanation of this option.

11. Click *Apply* to save the configuration. This also selects the printer.

Click *Reset* before *Apply* to discard any changes and to restore the previous configuration and printer selection.

12. Click *Exit* to exit the utility.

The following message appears if a change is made to the configuration when print jobs are currently queued:

*Warning - Configuration Change while Screen Copy
in Progress*

Whether a job prints according to the new or old configuration depends on timing. A print job already queued to the print manager uses the old configuration.

QUEUE NAME

Each printer used for screen printing must first be identified to the console by using the **DEFINEDEVICES** procedure. Refer to the **File Utilities** instruction for an explanation of the procedure (Table 1-2 lists instruction numbers). During this procedure, a queue name is automatically assigned to a printer to identify it to the print queue manager. The queue name is used in the screen copy configuration utility to direct a print job to a specific printer. A queue name is in the format:

$\$RSCQn$

where:

n Queue number from one to four that corresponds to printer one to four.

Selecting the same primary printer queue name in configurations that do not have the same printer type is not permitted. As long as the printer types are the same, the queue name can be used in more than one configuration. The following message appears if the printer types are different for configurations using the same queue name:

Queue x assigned to different printer types in configurations x and x

The message is only seen when configuration changes are applied.

PRINT ATTRIBUTES

The *Orientation* attribute selects either portrait or landscape printing.

The *Colors* attribute determines how the printer is to treat colors. If *As Viewed* is chosen, the printout uses the same color scheme as on the screen. If *Swap* is chosen, the colors in the printed version will be swapped based on the screen copy color map settings. Refer to **Screen Copy Color Map Utility** in this section. When printing OIS application windows that have a black background, it is suggested that the swap option be used and black be mapped to white.

The *Window Border* attribute determines whether or not the printed version screen contains the window border that

appears around the OIS application window. Choose *Include* to have the border print.

The *Color Mapping* attribute allows selecting either a color printout or a gray scale or black and white printout depending on the type of printer being configured. Access to the *Color* and *Grayscale/B&W* options is automatically enabled or disabled based on the type of printer selected.

NOTE: If using an HP LaserJet III or a DEClaser 2150, choose the *Grayscale/B&W* option.

CONSIDERATIONS

The amount of time it takes to print an image depends on:

Window Size	The larger the window, the longer it takes to process the image.
Border Option	When printing with the border on, the print head must travel the entire width of the image on every pass. Printing without a border reduces the travel distance, which speeds up the printing process. The effects of printing without a border are more evident when there is a large amount of blank space between the image and the border.
Color Mapping Option	Printing in color takes more processing time than printing in gray scale or black and white. Also, the data files for color printing are larger. This makes gray scale or black and white printing faster than color printing.
Image Complexity	The more complex the image, the longer the time required to process then print the image.

The recommended configuration to minimize print time is:

- Gray scale/black and white.
- Color swap enabled with black swapped with white.
- No border.

SCREEN COPY PRINTER FAILOVER

Printer failover can be enabled to automatically transfer the work load of a failed primary printer to a working backup printer with no information lost or delayed. When a printer is found to be stalled or stopped, the print job is removed from the failed printer and directed to a backup printer of the same type. Additionally, when the primary printer comes back on-line, failover automatically discontinues and any new work is directed to the primary printer. Any print jobs already queued to the backup printer when the primary comes back on-line, however, are completed by the backup printer.

A print job that transfers to a backup printer uses the print attributes configured for the printer from which it was transferred. For example, if a primary printer is configured for black and white printing and its backup printer is configured for color printing, a print job transferred from the primary printer prints on the backup printer in black and white.

Two options set during printer configuration are for printer failover: *Backup Queue Name* and *Discard Prints when Dead-End Encountered*. The discard option works whether a backup printer is selected or not.

When failover occurs, the following message appears in the OIS application window:

RSC failover on \$RSCQn, job #n

The failover status can be seen in the diagnostic log. Refer to the **File Utilities** instruction for information about the diagnostic log.

NOTE: When printing a small job, the print job will not failover to another printer if the job is no longer in the print queue when a printer fails.

Backup Queue Name

The *Backup Queue Name* is used to select a backup printer. Selecting a printer of a different type to be a backup printer is not permitted. For example, an HP Deskjet 550C printer can only failover to another HP Deskjet 550C printer. If a printer of a different type is selected, the following message appears:

Backup Queue x assigned to different printer types in configurations x and x

The message is only seen when configuration changes are applied.

The *Backup Queue Name* can be used to set up a printer failover sequence. For example, four screen printers that are all the same type are available. Printer one can be setup to failover to printer two, printer two to printer three, printer three to printer four, and printer four to printer one. By setting up failover in this way, all printers will be checked to find a working printer. If the last failover of printer four to printer one is not setup, the failover stops at printer four.

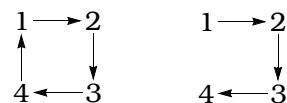

Example: If set up to fail from printer one to two and two to one and both printers have stopped or stalled, a print job is saved and both

printers are continuously checked until a working printer is found. If set up to fail from printer one to two but not two to one, a print job from printer one fails over to printer two but remains queued to printer two. It waits for printer two to come back on-line and never returns to printer one. Both examples assume discard prints is not enabled. In either example, if discard prints is enabled, the print job is canceled if both printers are found to have stopped or stalled.

Discard Prints

The *Discard Prints when Dead-End Encountered* option determines what is to be done with a print job if a working printer cannot be found. A print job directed to a failed printer can either be discarded or saved until a working printer can be found.

Enable the option to cancel a print job. All files associated with the print job will be deleted. Disable the option to save a print job until a working printer can be found.

The *Discard Prints when Dead-End Encountered* can be enabled even if the *Backup Queue Name* is set to *NONE*. If enabled, a print job is canceled and all associated files for the job queued to a stalled or stopped printer will be deleted. In this case, failover is not checked.

Initiating a Screen Copy

The following sections explain the two different methods for initiating a screen copy. It is recommended to use the command line menu *PRINT* option if blinking items in an OIS application window are important to a copy. The option freezes the blinking items before capturing the image. This guarantees that they will appear in the printout. The blinking items may or may not appear in the printout if using the *Screen Copy* option. This option does not freeze the blinking items before capturing the image.

NOTES:

1. Only two screen copies can be queued at one time.
2. The screen copy configuration utility does not have to be running to initiate a screen copy.

The *Screen Copy Color Map* option of the *OIS Utilities* pull-down menu can be used to set up color swapping. Refer to ***Screen Copy Color Map Utility*** in this section for the procedures to set up the color swapping.

COMMAND LINE MENU PRINT OPTION

The command line menu *PRINT* option is one method used to initiate a screen copy of an OIS application window. Before initiating a screen copy, make sure the printer that is to receive the print job has been configured and selected. Refer to **Configuring a Printer** and **Selecting a Printer** in this section for the procedures.

NOTE: When printing with the DEC LJ250, reduce the window size before initiating a screen copy.

To initiate a screen copy:

1. Set input focus to the OIS application window that is to be printed.
2. Press **COM'D LINE MENU**. This calls a bottom line menu.
3. Choose *D PRINT*. The screen freezes momentarily until captured for printing.

Refer to **Canceling a Queued Screen Copy** in this section for the procedures to cancel a print request.

PULL-DOWN MENU SCREEN COPY OPTION

The *Screen Copy* option of the *OIS Utilities* pull-down menu can be used to initiate a screen copy of any window including an OIS application window. Before initiating a screen copy, make sure the printer that is to receive the print job has been configured and selected. Refer to **Configuring a Printer** and **Selecting a Printer** in this section for more information.

To print a **selected window**:

1. From the session manager, choose *OIS Utilities*.
2. Choose *Screen Copy*. The mouse pointer changes in shape after selecting the option.
3. Point to the window that is to be printed and click MB1 or MB3 to initiate the print. The mouse pointer should return to its original shape after the print request is made.

To print the **entire screen**:

1. From the session manager, choose *OIS Utilities*.
2. Choose *Screen Copy*. The mouse pointer changes in shape after selecting the option.

3. Position the mouse pointer anywhere in the screen background, then click MB1 or MB3. The mouse pointer should return to its original shape after the print request is made.

To **cancel** the screen copy before selecting a window, click MB2. The mouse pointer should return to its original shape after canceling. Refer to **Canceling a Queued Screen Copy** in this section for the procedures to cancel a print request after it has been initiated.

Setting the Number of Copies

To set the number of copies to print:

1. Open the screen copy configuration window.
2. Enter the number of copies in the *Copies* field.
3. Click *Apply*.

Click *Reset* before *Apply* to cancel the change.

4. Click *Exit* to exit the utility.

Canceling a Queued Screen Copy

To cancel the last queued screen copy request:

1. From the session manager, choose *OIS Utilities*.
2. Choose *Abort Screen Copy*.

A dialog box appears to verify the cancellation.

Screen Copy Color Map Utility

The *Screen Copy Color Map* utility is used to set up color swapping. The utility is intended to allow changing the OIS application window background and the screen background for printing; however, any colors can be swapped.

To run the screen copy color map utility:

1. From the session manager, choose *OIS Utilities*.
2. Choose *Screen Copy Color Map*.

Buttons Click *OK* to save the changes and exit.

Click *Reset* to restore the previously saved color swap settings.

Click *Defaults* to restore the default color swaps as defined in the software.

Click *Cancel* to exit without saving.

SETTING UP A COLOR SWAP

A color swap works in two directions. For example, if set up to swap black with white, not only will black be swapped with white but white will be swapped with black.

A single color can only be swapped once. If a color is repeated in both color swap lines, the second swap will be ignored. For example, if set up to swap black with white and blue with white, the second swap of white with blue will not occur.

Black \longleftrightarrow White
Blue \longrightarrow White

The default color swapping is to swap black with white and to swap blue with white. When printing an OIS application window, this causes the black background to be printed in white and any white text to be printed in black. When printing the entire screen, this causes the blue background to print in white.

NOTE: Do not select blinking colors for swapping. The results of a blinking color swap are unpredictable.

To set up a color swap:

1. In the screen copy color map window, select the first color box of a swap line. The mouse pointer changes to a cross hair.
2. Place the cross hair over a color that is to be swapped, then click MB1.
3. Select the second color box of the swap line. Again the mouse pointer changes to a cross hair.
4. Place the cross hair over a color that the first color is to be swapped with, then click MB1.
5. Click *OK* to save the changes and exit.

NOTE: The OIS color palette display is a graphic that contains all 64 colors available for OIS displays. The display can be used to select colors for swapping. Use *Display by Name* and enter the display name as **ICLRPAL** to call the display.

Examples: Table 8-1 contains some examples of color swapping and describes the results of this swapping.

Table 8-1. Color Swap Examples

Example	Swap Setting	Result
A ¹	Swap black with white Swap blue with white	Black ↔ white Blue → white
B ²	Swap black with white Swap white with blue	Black ↔ white White ← blue
C ³	Swap black with white Swap white with black	Black ↔ white White black
D	Swap black with white Swap red with green	Black ↔ white Red ↔ green

NOTES:

1. Default settings.
2. Results are the same as example A.
3. Second swap is ignored.

COLOR SWAP CONSIDERATIONS

If *As Viewed* is set for the selected printer, color swapping is disabled.

If *Grayscale/B&W* is set for the selected printer, a color that is swapped to white will not appear in the printout. A color that is swapped to any other color except white prints in black.

TOUCH SCREEN

A touch screen provides an alternate method to interact with the console by emulating the actions normally performed with the mouse. Since touch screen works similar to the mouse, any discussion about mouse operation in this instruction or the **Configuration** instruction also applies directly to touch screen. This section discusses:

- Various setup options for touch screen.
- Procedures to initially and periodically calibrate the touch screen.
- Operation of touch screen in an OIS application window and in other MOTIF windows.

The touch screen setup procedure for an IIOIC42 auxiliary console is different than the setup procedure for a 40 series main console, and an IIOIC41 auxiliary console. This section provides both procedures.

Using the Touch Screen

With touch screen, the screen can be touched at a specific location to perform an action in the same way as can be performed by using a mouse (or trackball). Touch screen is operational at all times while the console is operating. The OIS application does not need to be active.

OIS Application

Within the OIS application, touch screen enables selecting a display element for control, calling another display, or choosing a menu option by touching a designated area on the screen. This designated area is called a touch point. A display must contain a touch point escape code (**ei 107**) for each of its active areas before a touch point select can be performed.

Pressing a touch point causes a short audible tone from the keyboard. Also, the outline of a display or display element changes to a highlight color when selected for control.

NOTE: The *Highlight Selected Touch Area* field on the general parameters page must be enabled during system configuration for highlighting to occur. Refer to the discussion on general parameters configuration in the **Configuration** instruction for the procedures to enable the field (Table 1-2 lists instruction numbers).

Other Applications

Outside the OIS application, touch screen enables the same MOTIF window operations that can normally be performed with the mouse, for example, setting input focus, relocating windows, selecting menu options, and minimize window or restore icon.

Touch Screen Setup Utility

The setup and calibration of a 40 series, and a IIOIC41 console touch screen is performed by using the touch screen setup utility. Refer to **IIOIC42 Touch Screen Setup** in this section for procedures to setup and calibrate an IIOIC42 console touch screen. Run the touch screen setup utility to:

- View the current touch screen settings.
- Define how touch screen is to operate.
- Perform calibration.

NOTE: In the touch screen setup utility, a depressed button indicates enabled. A raised button indicates disabled.

To run the touch screen setup utility:

1. From the session manager, choose *OIS Utilities*.
2. Choose *Touchscreen Setup*.

The touch screen setup utility can be run on the upper screen and the lower screen simultaneously. The setup only affects the operation of the screen on which it is running.

Buttons Click *OK* to apply any changes then exit the utility. This applies the current settings, but does not save the changes to file. Be sure to select *Save* prior to *OK* if the changes are to be saved.

Click *Apply* to apply the changes and leave the window open. The changes are not saved to file. The previous settings saved to file can be restored at any time.

Click *Save* to save any changes made to the setup and also the last calibration to file. The settings and calibration can then be restored from file. The information also becomes the defaults used during a boot-up.

Click *Restore* to restore the previous settings and the previous calibration. The button restores the information last saved to file.

Click *Command* to open a window to display touch coordinates. This is needed for calibration.

Click *Calibrate* to open a calibration window.

Click *Cancel* to exit the utility.

TOUCH SCREEN OPTIONS

The options in the touch screen setup utility:

- Enable or disable dragging.
- Enable or disable a touch tone.
- Adjust the touch tone volume.
- Adjust the touch sensitivity.
- Adjust the untouch time.

Choosing the Options

To setup touch screen:

1. Set the touchdown and liftoff options to enable the desired type of touch operation. Refer to ***Dragging*** in this section for a description of the options.
2. Enable or disable the *Audible Touch* option. If enabled, use the *Audible Touch Volume* slide bar to adjust the volume. Refer to ***Touch Tone*** in this section for a description of the option.
3. Set the *Jitter Control* by adjusting the slide bar. This may require some trial and error for proper adjustment. Refer to ***Touch Sensitivity*** in this section for a description of the setting.

4. Set the *Untouch Time* by adjusting the slide bar. This also may require some trial and error for proper adjustment. Refer to **Untouch Time** in this section for a description of the setting.
5. When completed, click either *Save* or *Apply*.

Click *Cancel* before any other buttons to exit without making any changes.

Dragging

The *Press* and *Release* settings determine how a screen touch will be interpreted. The touch screen can be setup to interpret a touchdown, liftoff, or both as a mouse click. One of three combinations of press and release options can be selected. The following describes the operating characteristics enabled by each combination.

- Option 1** Select *Press on Touchdown* and *Release on Liftoff* to enable dragging. This allows resizing and moving an active window as if pressing and holding the mouse button, dragging the pointer, then releasing the mouse button. The touch screen sequence to achieve the same result is to press the screen, keep pressure on the screen and move to the desired location, then release the screen.
- Option 2** Select *Press on Touchdown* and *Release on Touchdown* to disable dragging. A touch is immediately recognized as a mouse click when the screen is touched.
- Option 3** Select *Press on Liftoff* and *Release on Liftoff* to also disable dragging. With this setting, a touch is not recognized until the screen is released.

Touch Tone

Activate *Audible Touch* to enable a tone that sounds each time the screen is touched. Use this option to hear audible feedback to verify a touch selection. This option only affects the tone outside of graphics in the OIS application. Touching a point in an OIS application graphic causes a tone to sound whether *Audible Touch* is enabled or disabled. This feedback is internal to the OIS application and cannot be disabled. The *Audible Touch* option is disabled by default.

The *Audible Touch Volume* slide bar adjusts the tone volume. Adjust the slide bar to the desired volume level. The range is from zero to 100 with 100 being the loudest.

Touch Sensitivity

Use the *Jitter Control* slide bar to adjust touch screen sensitivity. The sensitivity may need to be adjusted if experiencing

problems accurately touching a point or if small movements are being interpreted as window moves rather than as a specific selection. The higher the jitter control number, the less sensitive the touch screen is to movement. Adjust the slide bar to the desired sensitivity. This may require some trial and error for proper adjustment.

Untouch Time

The *Untouch Time* slide bar adjusts the amount of delay necessary between touches for the console to recognize successive touches. For example, if the slide bar is set to one second then the operator must wait at least one second after a touch for the next touch to be recognized. The default for the slide bar is 0.15.

CALIBRATION

After initially installing touch screen, it must be calibrated. It can also be calibrated at any time to compensate for different operators.

NOTE: Within the OIS application, the *Calibrate Touch Screen* option does not function for this console.

Calibration Points

The *Calibration Points* slide bar sets the number of touch points used for calibration. The number of points ranges from four to 25. Each point appears as an icon that must be pressed during the calibration procedure.

Set the number of points before clicking *Calibrate*. The more points used, the more accurate the calibration.

Calibrating

To calibrate:

NOTE: Be sure the number of calibration points is set first.

1. Click *Calibrate*. This brings up a window that covers the entire screen. The window will contain from four to 25 touch point icons depending on the *Calibration Points* slide bar setting.
2. Press each touch point icon in succession as they become active. The pointer sequences to the next active icon as each is pressed. The previous icon is replaced by an x,y coordinate. Touch an icon as close to the center as possible. Do **not** try to move the pointer. The console returns to the setup window after the last icon is pressed.

Click MB3 at any time to exit calibration. MB3 is the right button by default.

3. When completed, click either *Save* or *Apply*.

Click *Restore* to cancel the calibration just performed and restore the previous calibration. Click *Cancel* before any other buttons to discard the calibration just performed.

The calibration may need to be repeated to fine tune the touch screen depending on the accuracy of the initial or previous calibration.

Testing the Calibration

The touch screen calibration can be verified for accuracy while performing the calibration procedure. To do this, compare the x,y coordinate shown as each touch point is pressed with previously pressed touch points. The x-coordinate of all vertical touch points in a given column should be within 100 of each other. The y-coordinate of all horizontal touch points in a given row should be within 100 of each other.

A bad coordinate pair is one where either the x-coordinate or the y-coordinate does not align with an adjacent coordinate as described. If bad coordinates appear, repeat the previous calibration procedure. If bad coordinates still appear, follow the procedures given in **Threshold Adjustment** in this section.

NOTE: The Signature Series Work Station uses capacitive touch screen; therefore, the threshold adjustment procedure does not apply. The verification can still be performed, but the adjustment cannot be made.

To further test the calibration:

1. Click *Command*. This brings up a command window that will display an x,y coordinate as one is received from the touch screen driver.
2. Pick a spot on the screen and press it. Note the resulting x,y coordinates that display.
3. Repeatedly tap the touch screen at the same location approximately 25 to 30 times. Observe the touch screen coordinates in the command window while doing this. All resulting x,y coordinates should be within 100 of each other. If any coordinates appear bad, follow the procedures given in **Threshold Adjustment** in this section.
4. Click *OK* when finished to close the command window.

Threshold Adjustment

NOTE: The threshold cannot be adjusted for an Signature Series Work Station.

To adjust the touch screen controller threshold to correct for coordinate errors:

1. Shutdown and power off the console.
2. Disconnect and remove the IIMKM02 module from the multibus card cage.
3. Adjust the R3 potentiometer ¼-turn counter clockwise (CCW).
4. Install and connect the IIMKM02 module.
5. Power up the console.
6. If calibrating a 40 series, or IIOIC41 console, verify the calibration as explained in ***Testing the Calibration*** in this section.

Do not repeat this procedure more than four times. If the R3 potentiometer is adjusted too much, the controller will stop transmitting coordinates. If this occurs, adjust R3 two full turns clockwise (CW) and repeat the adjustment procedure. If proper adjustment cannot be achieved, the touch screen controller is assumed to be bad. Replace the touch screen controller.

IIOIC42 Touch Screen Setup

The setup and calibration of an IIOIC42 console touch screen is performed through *Workspace* menu options. Refer to ***Touch Screen Setup Utility*** in this section for procedures to setup and calibrate a 40 series and IIOIC41 console touch screen.

NOTE: A depressed button indicates selected. A raised button indicates deselected.

To setup and calibrate the touch screen:

1. Call the *Workspace* menu and select *Local Clients* then *Tek-Setup*.
2. Select *Peripheral Ports* from the *Configuration Summaries* menu.
3. Verify *Serial Port 1* settings according to Table 8-2. Leave all other settings at their defaults. Do **not** make any changes to *Serial Port 0*.

Table 8-2. Touch Screen Serial Port 1 (Setup)

Option	Required Setting
Data bits	8
Stop bits	1
Parity	None
Flow control	None
Baud rate	4800
Socket number	Disabled

4. Select *Input Extension* from the *Configuration Summaries* menu.
5. Make sure *Touchscreen* is not currently selected as the core pointer device. If it is, click *Touchscreen* to deselect it.
6. Select *Device on Serial Port 1* according to Table 8-3. Do **not** make any changes to *Serial Port 0*.

Table 8-3. Touch Screen Serial Port 1 (Input Extension)

Selection	Activation Method	Description	Auxiliary Console
ptrBaileyCapT	Touchdown	Touch recognized immediately. Enables dragging.	IS43XA IS43XC (Signature)
ptrBaileyCapL	Liftoff	Touch not recognized until the screen is released. Disables dragging.	
ptrBaileyResT	Touchdown	Touch recognized immediately. Enables dragging.	IIOIC42
ptrBaileyResL	Liftoff	Touch not recognized until the screen is released. Disables dragging.	

7. Click *Touchscreen* to select touch screen as the core pointer device.
8. Calibrate the touch screen.
 - a. Click *Start Calibration*.
 - b. Touch the + at the lower left corner as close to the center as possible.
 - c. Touch the + at the upper right corner as close to the center as possible.
9. Click *Return to Main Menu*.

10. Click *Save Settings to NVRAM*.
11. Click *Exit Setup*.

IIOIC42 Calibration

After initially setting up the touch screen, it must be calibrated. It can also be calibrated at any time to compensate for different operators.

To calibrate the touch screen:

1. Call the *Workspace* menu and select *Local Clients* then *Tek-Setup*.
2. Select *Input Extension* from the *Configuration Summaries* menu.
3. Click *Touchscreen* to select touch screen as the core pointer device.
4. Click *Start Calibration*.
5. Touch the + at the lower left corner as close to the center as possible.
6. Touch the + at the upper right corner as close to the center as possible.
7. Click *Return to Main Menu*.
8. Click *Save Settings to NVRAM*.
9. Click *Exit Setup*.

If experiencing problems accurately touching a point, repeat the calibration procedure. If still experiencing problems, repeat the calibration several times taking note of the x- and y-coordinates returned in the X,Y fields. The coordinates should not vary by more than 100. If they do, perform the threshold adjustment procedure given in **CALIBRATION** in this section, then repeat the calibration.

To update the x,y coordinates:

1. Click *Return to Main Menu*.
2. Select *Input Extension* from the *Configuration Summaries* menu.

- or -

1. Point and click in the *Lower Left Device X,Y* field.

2. Point and click in the *Upper Left Device X,Y* field.
3. Point and click in the *Lower Left Device X,Y* field.

TOUCH PAD

A touch pad is a window that emulates some of the actions that can be performed from the operator keyboard. Touch points allow interacting with the touch pad using either the mouse, trackball, or touch screen. There are five different touch pads: display, numeric, control, operator keyboard, and auxiliary keyboard. Figures 8-1, 8-2, 8-3, and 8-4 show the standard versions of the display, numeric, control, and operator keyboard touch pads.

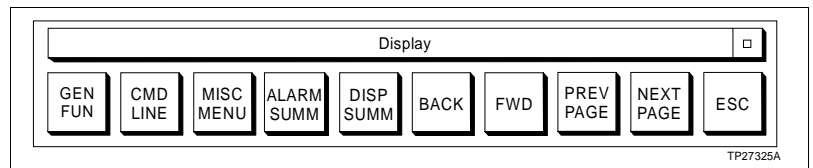

Figure 8-1. Standard Display Touch Pad (Small Key Size)

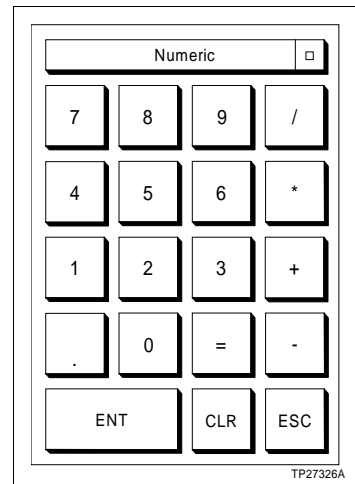

Figure 8-2. Standard Numeric Touch Pad

The display touch pad provides some of the same functions that are found in the display control block section of the operator keyboard. The numeric touch pad is functionally the same as the numeric keypad on the keyboard, but does not include any punctuation keys. The buttons of the control touch pad are functionally the same as the keys in the station and remote control block keyboard section with the addition of an enter (*ENT*) and escape (*ESC*) button.

NOTE: The ALARM SUMM and DISP SUMM buttons do not appear when the display touch pad uses the standard key size.

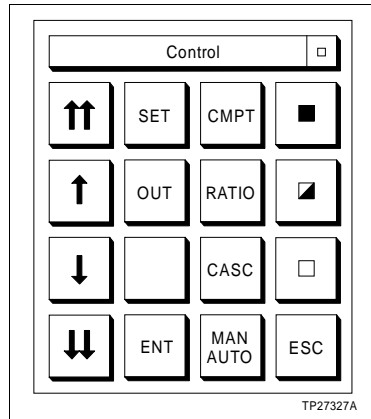

Figure 8-3. Standard Control Touch Pad

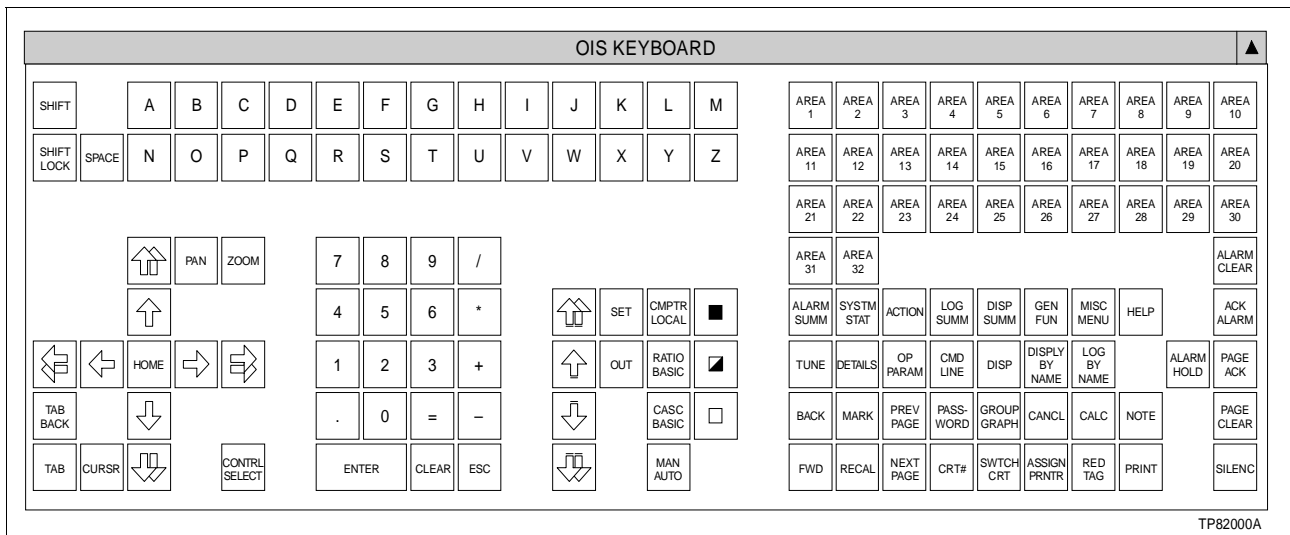

Figure 8-4. Operator Keyboard Touch Pad

The operator keyboard touch pad provides all the same functions found on the physical operator keyboard. The auxiliary keyboard touch pads provides the same functions as found on the physical auxiliary keyboard. A description of this keyboard can be found in [Appendix A](#). The auxiliary keyboard touch pad contains all the functionality of the physical keyboard. The basic alphanumeric key layout (QWERTY) functionality is provided in the auxiliary keyboard touch pad. The keypad, however, contains only the key functionality of the numeric keypad section.

Refer to **KEYBOARD LAYOUT** in Section 3 for the location of the equivalent operator keyboard keys and a description of the functions they perform. Refer to [Section 9](#) and [Section 10](#) for an explanation of the process control actions performed from the control touch pad.

OIS Application Configuration Requirements

The *Enable Control From Pointing Device* field must be enabled on the general parameters page during system configuration to enable the touch pads. Refer to the discussion on general parameters configuration in the **Configuration** instruction for the procedures to enable the field (Table 1-2 lists instruction numbers).

NOTE: For an IIOIC42 auxiliary console, touch pads are enabled after the touch pad configuration utility is run for the first time.

Touch Pad Configuration Utility

Some set up options are provided for the touch pads. The configuration for a touch pad can be changed at any time. Each touch pad can be activated or deactivated individually. Only three touch pads can be activated for a CRT at one time. The activated touch pads are the first three in the touch pad configuration listing that have a YES listed under CRT1 or CRT2. Different touch pads can be activated on different CRT's.

NOTE: In the touch pad configuration utility, a depressed button (denoted by shading on the left and top) indicates enabled. A raised button (denoted by shading on the right and bottom) indicates disabled.

To run the touch pad configuration utility:

1. From the session manager, choose *OIS Utilities*.
2. Choose *Touch Pad Configuration*.

Buttons

Click *Configure* to call the configuration window for the selected touch pad or to create a new touch pad.

Click *Remove* to delete the selected touch pad from the touch pad configuration listing.

Click *Activate* after setting up the touch pads to put any changes into effect.

Click *Exit* to save any changes made to touch pad configuration files and exit utility.

IIOIC42 Touch Pads

When the touch pad configuration utility is run for the first time on an IIOIC42 console, a dialog box appears asking whether this console should use the same configuration files as the main console. The choices are to share the same configuration files as the main console or create private configuration files.

Shared If the touch pads are to be configured the same as on the main console:

1. Click *Yes* in response to the dialog box. After a short time, the touch pad configuration utility window will appear.
2. Click *Activate*.
3. Click *Exit* to exit the utility.

This designates the touch pad configuration files as shared. If the shared configuration files are changed, *Activate* only restarts the touch pads for the node on which the touch pad configuration utility is running. To activate the changes for touch pads on other consoles that use the shared configuration files, either use the touch pad configuration utility to activate the touch pads on each console or use the **RESTARTALLTOUCHPADS** command.

Private If the touch pads on the IIOIC42 console are to be configured different than on the main console:

1. Click *No* in response to the dialog box.
2. Log into the SYSTEM account on the main console.
3. Type:

```
ADDTOUCHPAD nodename DECNET PRIVATE 
```

where:

```
nodename      Name of the IIOIC42 console.
```

4. Run the touch pad configuration utility.
5. Configure the touch pads as described in **Configuring Touch Pads** in this section.

Refer to the **File Utilities** instruction for a description of the following touch pad commands:

```
ADDTOUCHPAD
REMOVETOUCHPAD
RESTARTALLTOUCHPADS
SHOWTOUCHPADS
```

Configuring Touch Pads

Both standard and custom touch pads are configured in the configure touch pad window. The CRT activation, initial state, and key size can be configured for both standard and custom touch pads. Custom touch pads also allow the amount of keys,

key selection, and key pad orientation to be configured. To configure a touch pad:

1. Select the name of a custom touch pad that requires reconfiguration or select *New* to configure a new touch pad. Click *Configure*. This causes the configuration touch pad window to display.
2. Choose which screen, CRT1 for the lower or CRT2 for the upper, that the touch pad will be displayed on.
3. Choose the initial state that the touch pad will appear on the CRT : window or icon.

Window - the touch pad is initially displayed as an open window with all touch pad keys visible.

Icon - the icon contains the name of the touch pad.

4. Choose key size for touch pad : standard or small.

Standard - maximum touch pad matrix size is 16 x 20 keys.

Small - maximum touch pad matrix size is 22 x 28 keys.

5. The *Touch Pad Description* text box contains a description of the touch pad. Click inside the text box to enter a new description (required when a new custom touch pad is configured) or to change the current description. The description is limited to 30 characters.

6. The *Window/Icon* text box contains the name of the touch pad. Click inside the text box to enter a new label (for a new custom touch pad) or to change the current label. The label is limited to 30 characters.

7. Configure the touch pad layout. If reconfiguring a custom touch pad, use the mouse to resize, reposition, and reorient the key layout in the window. If configuring a new custom touch pad, use the mouse to change the size, orientation, and position of the window. Changing the size and orientation of the window adjusts the number of push button keys available.

8. Copy keys from the keyboard palette to the touch pad by first clicking on the key in the touch pad then clicking on the key in the keyboard palette. Any touch key in a custom touch pad can be changed.

The keyboard palette includes all the functionality of the standard operator keyboard as well as some additional keys. The new keys provide access to select station and remote control block key functionality that would normally be accessed by toggling between different operation modes and are described below.

The **MAN/AUTO** operator keyboard key functionality is provided by separate MANUAL and AUTO touch pad keys.

The **CMPTR** operator keyboard key, which toggles between the computer and local mode, functionality is provided by separate CMPTR and LOCAL touch pad keys.

The **CASCADE** operator keyboard key, which toggles between basic and cascade operation, functionality is provided by separate CASC and BASIC touch pad keys.

The **RATIO** operator keyboard key, which toggles between basic and ratio operation, functionality is provided by separate RATIO and BASIC touch pad keys.

Also the ramping touch pad keys are distinguished from the cursor/trend control arrow touch pad keys in that the ramp value arrow keys have an additional bar at the end of the shaft.

9. Click *OK* to accept the custom touch pad configuration or *CANCEL* to void changes. Both commands close the configuration touch pad window and returns to the configure touch pad window.

10. Click either *ACTIVATE* or *EXIT*.

The *ACTIVATE* option provides the option to save the new custom touch pad configuration or activate a previous configuration.

Select *YES* to save and activate a new custom touch pad configuration.

Select *NO* to activate previous custom touch pad settings.

Select *CANCEL* to terminate activation.

NOTE: A new custom touch pad configuration must be saved in order to be activated.

The *EXIT* option provides the option to either save the new custom touch pad configuration before exiting, or exit without saving any changes.

Select *YES* to save custom touch pad configuration and exit utility.

Select *NO* to exit utility without saving changes.

Select *CANCEL* to return to touch pad configuration window.

Using a Touch Pad

Using a touch pad does not change window input focus. The touch pads work only for the OIS application window that currently has input focus. Use the touch pad keys in the same way that the keyboard keys are used. The result of a touch pad action is the same as its equivalent keyboard key. The keyboard and touch pads can be used simultaneously. A touch pad window can be shrunk to an icon and moved in the same way as other windows.

NOTE: Do *not* position the touch pads so they overlap. This causes overlapped touch pads to continually try to come to the foreground wasting excessive amounts of CPU processing time.

CONFIGURING THE MOUSE CURSOR

A different mouse cursor shape, foreground color, and background color can be selected through the cursor configuration dialog box. The configuration dialog box for the mouse cursor is accessed through the *OIS Utilities* menu option.

To access the mouse cursor configuration utility:

1. From the session manager, choose *OIS Utilities*.
2. Choose *Cursor Configuration*.

NOTE: Simultaneous multiple console access to the cursor configuration utility is prohibited. If a number of consoles try to access this utility at the same time an error message will appear on the screen indicating that the console is unable to run the utility because it is already running on another console in the system. Indication of which node is currently accessing the utility is provided.

Buttons Click *FOREGROUND* to select a new foreground color for the mouse cursor.

Click *BACKGROUND* to select a new background color for the mouse cursor.

Click *OK* after making cursor style and color selections. This saves the settings and exits the utility.

Click *RESET* to restore the previous cursor style and color selections.

Click *DEFAULT* to set the cursor style and color settings to default (i.e., white crosshair with black background).

Click *CANCEL* to exit the utility without saving changes.

Selecting a Mouse Cursor Style

Select a new mouse cursor style by either choosing one of the available cursor styles displayed in a scrollable list, or by entering the name of a user-defined cursor.

To select a cursor style from the scroll list use either the scroll box or arrows to scroll through all the available selections then click on the desired cursor style.

To select a user-defined cursor enter the name of the cursor in the text box and click *OK*.

NOTE: The name of a user defined cursor specifies two different files. The first file defines which pixels will be the foreground color and which will be the background color. The second file defines which pixels are on and which are off. The on pixels define the overall cursor shape, which is also known as the mask. The following are example file names: EB_CURSOR.XBM; EB_CURSOR_MASK.XBM.

If the file cannot be located or was not set up properly an error message will appear at the bottom of the *OIS Cursor Configuration* dialog box, and the entry will not be allowed. The error message will also be entered into the diagnostic log.

The selected cursor style will appear in the current cursor window.

CHANGE MOUSE CURSOR COLORS

The cursor colors are changed through selection of the foreground and background color buttons. Selection of a color button automatically opens the *OIS Cursor Color* dialog box. This dialog box provides five different methods in which to generate and select a background and foreground color.

To select a new color.

1. Click *COLOR MODEL* to select the method of color selection. The name of the selected method will appear in the button.
2. Depending upon the color model selected, choose or generate the desired color. The new color will appear in the right half of the color display box (this is the rectangular box located below the title bar). The current background or foreground color appears in the left half of the box.

Buttons Click *SCRATCH PAD...* to open a window that will temporarily hold the last selected or generated color. This allows for color comparisons to be made.

Click *OK* to save the color selection and exit utility.

Click *APPLY* to apply the selected color to the current cursor. This provides the capability to preview the color before saving any changes.

Click *RESET* to restore the previous color selection.

Click *CANCEL* to exit without saving any changes.

Click *HELP* to access Bookreader to see available help screens on this utility.

Picker Color Model

This is the default color selection model. The picker allows selection of a color from one of four available color pallets as well as interpolation and adjustment of tones between two selected colors from the pallet. To generate and select a color:

1. Click the pallet button located right below the *COLOR MODEL* to select the desired color pallet. This button contains the name of the color pallet being displayed. The default is spectrum. Other pallets available are pastels, vivids, and earthtones.

2. A color can be selected directly from the color pallet bar by clicking on the desired color. Variations of two colors, displayed in the pallet, can be generated by first clicking on a color, then clicking on a paint can icon at either end of the interpolator pallet bar. Repeat this procedure so there is a color at each end of the bar. An interpolation of colors is generated by clicking *SMEAR*. If none of the colors generated are acceptable the interpolator pallet bar can be cleared by clicking *RESET*. The *UNDO* button displays the last set of interpolated colors.

Buttons The following buttons adjust the tone of the colors displayed in the interpolator color pallet bar.

Click *LIGHTER* to lighten displayed colors.

Click *DARKER* to darken displayed colors.

Click *WARMER* to increase the amount of yellow-orange-red hue in the displayed colors.

Click *COOLER* to increase the amount of violet-green-blue hue in the displayed colors.

HLS Color Model

The HLS color model allows for creation of a cursor color through adjustment of the hue, lightness, and saturation slide bar settings. The HLS color model also allows for an adjustment of a color selected from either the picker or browser color

models. Adjustments are automatically displayed in the right half of the color display box. A numeric value, representative of the slide bar position, is displayed above the slide bar.

Slide Bars Drag the *HUE* slide bar to adjust the gradation of color; range is 0 to 359.

Drag the *LIGHTNESS* slide bar to adjust brightness of color; range is 0 to 100, where 0 is black and 100 is white.

Drag the *SATURATION* slide bar to adjust the amount of gray tone blended in the displayed color; range is 0 to 100, where 0 is maximum gray and 100 is maximum color.

RGB Color Model

The RGB color model allows for the creation of a cursor color through the adjustment of the amount of red, green, and blue slide bar settings. The RGB color model also allows for an adjustment of a color selected from either the picker or browser color models. Adjustments are automatically displayed in the right half of the color display box. Each scale has a range of 0 to 65535. A numeric value, representative of the slide bar setting, is displayed to the right of the slide bar.

Slide Bars Drag the *RED* slide bar to adjust the amount of red color tone.

Drag the *GREEN* slide bar to adjust the amount of green color tone.

Drag the *BLUE* slide bar to adjust the amount of blue color tone.

Browser Color Model

The browser color model allows for selection of a cursor color from a displayed list. Each displayed color is labelled.

To select a color:

1. Either click on the scroll arrows located on the top and bottom of the scroll bar or drag the scroll box located inside the scroll bar until the desired color is displayed.
2. Click on the desired color to select it. The color will now appear in the right half of the display color box.

Grayscale Color Model

The grayscale color model allows for the creation of a gray color tone cursor. It provides an adjustable slide bar to vary the amount of gray tone.

The amount of grayscale is adjusted by dragging the slide bar. The scale range is 0 to 100, where 0 is black and 100 is white. A numeric value, representative of the slide bar setting, is displayed above the slide bar. Adjustments are automatically displayed in the right half of the color display box.

CONFIGURING THE OIS WINDOW ENVIRONMENT

The window features that will be made available to the operator are configured using the environment configuration utility. This utility provides the ability to select which functions each of the OIS windows will have. Windows can be configured to remain at a fixed size and location or allow for changes in size and location, as well as, minimization and maximization. The configuration dialog box for the OIS window environment is accessed through the *OIS Utilities* menu option. Run the utility to:

- Select the window to configure.
- Select which window functions to activate or deactivate.
- Select inclusion of window features such as menu bar, tear-off menus, restore window location or size at start-up, and start-up display.

To run the configuration utility:

1. From session manager, select *OIS Utilities*.
2. Select *Environment Configuration*.

NOTE: Simultaneous multiple console access to the environment configuration utility is prohibited. If a number of consoles try to access this utility at the same time an error message will appear on the screen indicating that the console is unable to run the utility because it is already running on another console in the system. Indication of which node is currently accessing the utility is provided.

Buttons Click *OK* after selecting window functions, border decorations, and window features that are to be employed. This saves the settings to disk and exits the utility.

Click *RESET* to restore the previously saved settings.

Click *DEFAULT* to change the current settings to established default settings.

Click *CANCEL* to exit the configuration utility without saving the changes.

Selecting Windows Capabilities/Features

The capabilities and features that a particular OIS window will have depend upon the selected functions, decorations, and display features. To select these items:

1. Select the window that is to be configured.
2. Select which window function, decoration, and feature items are to be active. The items are selected by clicking on the button to the left of the item title.

Refer to **WINDOWS SYSTEM** for a discussion on windows operation.

Buttons Click *SIZE* to allow the operator to vary size of the window. The *RESIZE BORDER* must be selected in order to use the mouse to resize the window.

Click *MOVE* to allow the operator to relocate the window on the screen. *TITLE* must also be selected in order to use the mouse to move the window.

Click *MINIMIZE* to allow the operator to minimize the window to an icon. *TITLE* and *MINIMIZE BUTTON* must also be selected in order to use the mouse to minimize the window.

Click *MAXIMIZE* to allow the operator to maximize the window to its maximum allowable size. *TITLE* and *MAXIMIZE BUTTON* must also be selected in order to use the mouse to maximize the window.

Click *CLOSE* to allow the operator to be able to close the OIS window. *TITLE* and *MENU* must also be selected in order to use the mouse to close the window.

Click *RESIZE BORDER* to allow the operator to resize the window using the mouse cursor. *SIZE* must also be selected otherwise this border decoration will not be active.

Click *WINDOW BORDER* to have a frame, which encloses the open window, appear on the screen.

Click *MINIMIZE BUTTON* in order to use the mouse to minimize the window to an icon. *TITLE* must be selected for the minimize button to appear in the upper right corner of the window. Also, *MINIMIZE* function must be selected otherwise this button will not be active.

Click *MAXIMIZE BUTTON* in order to use the mouse to maximize the window to its maximum allowable size. *TITLE* must be selected for the maximize button to appear in the upper right

corner of the window. Also, *MAXIMIZE* function must be selected otherwise this button will not be active.

Click *TITLE* to display the title bar along the top of the window. This is required if *MINIMIZE BUTTON*, *MAXIMIZE BUTTON*, or *MENU* are selected.

Click *MENU* to provide the window control button. This button provides access to the window control menu. *TITLE* must be selected in order for the window control button to appear in the upper left hand corner of the window.

Click *OIS MENU BAR* to display the menu bar along the top of the window just below the title bar. This provides access to pull down menus containing either standard or custom options.

Click *OIS TEAR-OFF MENUS* to provide the operator the capability to tear off any of the pull-down menus. This allows for the pull-down menus to be repositioned on the display so that the operator can see the entire window without having the pull-down menu in the way or having access to menu options when the window is pushed to the back of the stack.

Click *RESTORE WINDOW LOCATION/SIZE AT STARTUP* to restore the window to its size and location on the screen before an OIS shutdown occurred.

Click *STARTUP DISPLAY* to designate the window display that will appear upon an OIS start-up. The file name of the display is entered into the text box to the right of the command. If the display file does not exist an error message will appear along the bottom of the *Environment Configuration* window and be written to the diagnostic log.

If *STARTUP DISPLAY* is not selected or the display file does not exist the general functions menu will be displayed.

CONFIGURING THE MENU BAR

A custom OIS window menu bar and associated pull-down menus can be configured using the *Main Configuration* window. This feature provides the ability to add, remove, or reposition menu bar labels, and create pull-down and submenus which contain display call-up functions, menu options, and OIS functions. The same custom menu bar is used on all OIS windows.

Main Configuration Window

The *Main Configuration* window consists of a function menu bar, configuration area, and the move buttons. The function menu bar contains the *File*, *Edit*, and *Insert* menu options. These options allow for the creation and modification of a cus-

tom OIS menu bar and associated pull-down and submenus. The configuration area contains the custom menu bar as it appears on all OIS windows, and the pull-down menu hierarchy structure of a selected menu bar label.

Menu labels, which have associated submenus, are enclosed by outward angle brackets (< and >) to differentiate them from functional items. These menus are referred to as closed. Initially, the submenus are not displayed. Positioning the mouse pointer on a menu label and double clicking the MB1 mouse button, displays the associated submenu. Double clicking MB1 on the menu label will also cause the submenu to close, that is, hide it from view. When the submenu is open the menu label is enclosed by inward angle brackets (> and <).

Items in menu hierarchy can be selected through drag operation. Any single menu item or a group of contiguous menu items can be selected (highlighted) at the same time.

To access the *Main Configuration* window:

1. From the session manager, choose *OIS Utilities*.
2. Choose *Menu Bar Configuration*.

File Options Click *FILE* to access the following custom menu file options:

Click *SAVE* to save the current menu configuration to disk.

Click *EXIT* to exit the *Main Configuration* window. If changes have not been saved a dialog box will appear. The operator is able to either click *YES* to save changes before exiting, click *NO* to exit without saving changes, or click *CANCEL* to return to the *Main Configuration* window.

Edit Options Click *EDIT* to access the following custom menu file editing options:

Click *CUT* to remove selected items from menu hierarchy and place them on the clipboard. The clipboard is a temporary holding area in memory. Items will remain in the clipboard until a paste operation is performed, or either a copy or another cut operation is performed. This replaces the previous contents of the clipboard with the latest selection. If the cut items has submenus associated with it the submenus will also be cut. The menu hierarchy, displayed in the configuration area, will be updated to reflect the changes.

Click *COPY* to copy the selected menu items onto the clipboard. If a selected item has submenus associated with them, the submenus will also be copied. The menu hierarchy, displayed in the configuration area, will be updated to reflect the changes.

Click *PASTE* to insert contents of clipboard into the menu hierarchy below currently selected item. If the selected item is closed, the contents of the clipboard are inserted below it. If the selected item is open, the contents of the clipboard are inserted into the associated submenu. The menu hierarchy, displayed in the configuration area, will be updated to reflect the changes.

Click *MODIFY* to perform modifications to the selected menu item. One of three windows will appear, depending on the item selected.

- If the selected item is a menu option label, the *Menu Configuration* dialog box will be displayed. Refer to **Menu Label Configuration Dialog Box**, in this section, for a description.
- If the selected item is a display label, the *Display Configuration* dialog box will be displayed. Refer to **Display Configuration Dialog Box**, in this section, for a description.
- If the selected item is an OIS menu option, the *OIS Function Configuration* dialog box will be displayed. Refer to **OIS Function Configuration Dialog Box**, in this section, for a description.

Click *MOVE UP* to move a selected item up a position in its menu hierarchy. An item at the top of a menu list cannot be moved upward. Trying to do so causes an audible tone to sound to notify the operator of the error.

Click *MOVE DOWN* to move a selected item down a position in its menu hierarchy. An item at the bottom of a menu cannot be moved downward. Trying to do so causes an audible tone to sound to notify the operator of the error.

Click *LEFT/OUT* to either move a selected submenu item to the same hierarchal level as its menu label, or move a selected menu bar option label one position to the left.

Click *RIGHT/IN* to move a selected item into a submenu, that is a hierarchal level below its present position. If no submenu is present, in the hierarchal structure, and audible tone will sound to notify the operator of the error and no change will occur. Any item moved into a submenu will appear on top of the submenu. This button can also be used to move a selected menu bar item option label one position to the right.

Insert Option

Click *INSERT* to access the following custom menu build options:

Click *MENU* to add a menu item to either the menu bar, a menu, or a submenu. This is accomplished through the *Menu*

Configuration dialog box. Refer to **Menu Label Configuration Dialog Box**, in this section, for a description.

Click *DISPLAY* to add an OIS display into a custom menu. This is accomplished through the *Display Configuration* window. Refer to **Display Configuration Dialog Box**, in this section, for a description.

Click *OIS FUNCTIONS* to add standard OIS menu options into a custom menu. This is accomplished through the OIS Functions and Menus dialog box. Refer to **OIS Standard Function Menu Configuration Dialog Box**, in this section, for a description.

Click *SEPARATOR* to add a line below the selected menu label. This is used to separate menu labels in pull-down menu hierarchies.

Buttons Click *LEFT*, *RIGHT*, *UP*, and *DOWN TRIANGLE* to move selected items within a menu.

Clicking *LEFT TRIANGLE* has the same effect as the *LEFT/OUT* menu option.

Clicking *RIGHT TRIANGLE* has the same effect as the *RIGHT/IN* menu option.

Clicking *UP TRIANGLE* has the same effect as the *MOVE UP* menu option.

Clicking *DOWN TRIANGLE* has the same effect as the *MOVE DOWN* menu option.

Display Configuration Dialog Box

This dialog box provides the capability to insert an OIS display into a custom menu hierarchy, modify a display label, or select a different display call-up function file. To open this dialog box, from the *Main Configuration* window do one of the following:

Choose *Insert* and then choose *Display*.

- **or** -

Double click on a display label in a custom menu hierarchy.

- **or** -

Highlight a display label in a menu hierarchy, choose *Edit* and then choose *Modify*.

This dialog box contains a scrollable list of the display call-up function files and associated display titles. The first time this

dialog box is accessed no files will appear in the list. The operator will need to choose *Update*. The display call-up function files are listed in alphabetical order.

To insert a display title into the menu hierarchy either:

Select a display call-up function file name in the listing, then click *Insert*.

- *or* -

Double click on a display call-up function file name in the listing.

This will insert the associated display label either below a selected closed menu item, or at the top of a submenu if the selected item is open.

Text Boxes

Click inside the *LABEL* text box to enter or modify the display label associated with the display call-up function file. The label is limited to 40 characters in length.

The display label is what is inserted into the custom menu hierarchal structure. When the operator selects the label the display call-up function file is activated.

Click inside the *DISPLAY NAME* text box to enter the name of the display call-up function file. A search is performed to find the file in the display file list or on the console hard disk drive. If the display call-up function file is not found the operator is notified that is not installed on the system. If it is found on the hard disk drive it is added to the list. If it is found in the list, the display title will appear in the *LABEL* text box.

Click inside the *SEARCH* text box to enter in the name of a display call-up function file or display label. Click on *SEARCH NAME/SEARCH LABEL* to indicate whether you are searching for a file or a label. The ? and * wildcard characters can be used to search for a number of files that have the same character(s) in the file name or label. The ? represents a single character and the * represents any number of characters. When wildcards are used the first file name or label that meets the requirements is highlighted.

Buttons

Click *OK* to perform one of the following actions:

- If display title was modified, save changes to display list.
- If a menu item was selected before the *Display Configuration* dialog box was opened, insert display label into the appropriate position in the custom menu hierarchy.

- If the *Display Configuration* dialog box is accessed by double clicking on a display label in the custom menu hierarchy, apply changes to the display label in menu.

The *Display Name* text box must contain a file name in order for desired action to occur.

Click *REPLACE* to apply changes to the selected label or to change which display call-up function file is accessed from the custom menu hierarchy.

Click *INSERT* to insert the selected display label into the custom menu hierarchy displayed in *Main Configuration*.

Click *CLOSE* to close the dialog box.

Click *SEARCH* to search for the file name or label typed into the *SEARCH* text box.

Click *UPDATE* to add the display files to the list.

Click in the box next to *USE DISPLAY NAME AS DEFAULT LABEL* to use the file name as the display label in the menu hierarchy instead of the display label associated with the display file.

Menu Label Configuration Dialog Box

This dialog box provides the capability to create new menu option labels or modify existing menu option labels. To open this dialog box, from the *Main Configuration* window, either:

Choose *Insert* and then *Menu*.

- or -

Highlight a menu label, choose *Edit*, then *Modify*.

Text Box Click inside the *LABEL* text box to either create a new menu option or modify an existing menu label. Menu labels are limited to 40 characters.

Buttons Click *OK* to insert a new menu option or to apply the changes to the modified menu label.

Click *REPLACE* to apply changes to a modified menu label.

Click *INSERT* to insert the new menu option into either the custom menu hierarchical structure below the highlighted option, or into the menu bar, if a menu bar option is highlighted.

Click *CANCEL* to close the dialog box without making any changes to the label or menu.

OIS Standard Function Menu Configuration Dialog Box

This dialog box provides the capability to insert a standard OIS menu option and label into a custom menu hierarchy. To open this dialog box from the *Main Configuration* window, choose *Insert*, then *OIS Functions*.

The dialog box displays a scrollable list of all OIS menu options and labels. Menu labels are enclosed by outward angle brackets (< and >). This is to differentiate them from functional menu options. The associated submenus are not initially displayed. Double clicking on the menu label opens or closes the associated submenu.

To insert an OIS menu label or option either:

Highlight an item in the list and click on *Insert*.

- or -

Double click on an item in the list.

The selected item will be inserted into the custom menu hierarchy, displayed in the *Main Configuration* window, below the highlighted menu option or label. If a menu label was selected the label and associated submenu will be inserted.

Buttons

Click *OK* to insert the selected menu label or option into custom menu hierarchy and close dialog box.

Click *INSERT* to insert the selected menu label or option into the custom menu hierarchy.

Click *CLOSE* to close the window.

Click on *VIEW UNUSED* to display which standard OIS menu labels and options are not used in the custom menu configuration. When *VIEW UNUSED* is selected the button label changes to *VIEW ALL* if all the standard OIS menu labels or options are not used in the custom menu configuration.

OIS Function Configuration Dialog Box

This dialog box provides the capability to modify an OIS option label that has been inserted into a custom menu hierarchy. This only changes the label, not the functionality of the option. To open this dialog box, from the *Main Configuration* window either:

Highlight an OIS option label in a custom menu hierarchy, choose *Edit*, then choose *Modify*.

or

Double click on the OIS option label in a custom menu hierarchy.

A short description of the OIS option is displayed in the dialog box to indicate what operations are performed by the option.

Buttons Click on *OK* to apply the changes to the OIS option label.

Click on *REPLACE* to apply the changes to the OIS option label.

Click on *CLOSE* to close the window.

SECTION 9 - PROCESS CONTROL

INTRODUCTION

The console gives access to INFI 90 OPEN control modules to monitor automatic control and to initiate manual control of a process. Device control can be performed to logically turn on or off, set or reset, and start or stop a process device. Loop control can be performed to change the set point, ratio index, or control output of a control loop.

This section explains and provides procedures for device and loop control initiated from standard faceplate elements designed to mimic process devices. These symbols are provided with the console. The procedures and operations explained in this section remain the same for custom faceplates designed to provide the same capabilities although they may not and do not have to include all features if not required. The escape commands defined in a symbol file during creation determine the capabilities of a faceplate. Refer to [Section 4](#) for further explanation.

NOTE: Refer to the *Display Builder Reference* instruction for a description of additional display elements that can be incorporated into a display or a custom faceplate beyond those described in this section (Table 1-2 lists instruction numbers).

PROCESS CONTROL FUNCTIONS

Control functions provide the ability to monitor individual process variables and devices, and provide the ability to perform manual and automatic mode device control. Process information is received in exception reports from function blocks configured in a PCU module. The control ability allows changing process conditions from the console by initiating changes to the PCU module. A PCU module receives input from and sends output signals to the process through termination units connected to process devices and stations.

NOTE: Control abilities can be limited to specific personnel by defining password security. The security level of a user must give control access rights before any control can be initiated.

Control Faceplates

Dynamic faceplates for the different types of control tags can be either standard or user-created. Standard control elements are provided. A control element can be a fixed part of a display or it can be called as a pop up element. The same control actions can be performed from a fixed element as can be performed from a pop up element. This assumes that the symbol

file used for the fixed element is also the same one used for the pop up element, or the pop up element, if different, has all the same capabilities as the fixed element built in.

Control Tags

Control tags provide access to control function blocks within a module. The access can be used to manually initiate process changes and to monitor the results of both automatic and manual control operations. Automatic refers to operation being performed under PCU module execution. Manual refers to those actions initiated after taking a function block out of automatic PCU control. Table 9-1 lists the control tags and the function codes (FC) they associate with. Refer to the **Function Code Application Manual** for a description of these function codes and their specifications (Table 1-2 lists instruction numbers).

Table 9-1. Control Tags

Tag	Function Code ¹
DD	Device driver, FC 123.
MSDD	Multi-state device driver, FC 129.
RCM	Remote control memory, FC 62.
RMCB	Remote motor control, FC 136.
RMSC	Remote manual set constant, FC 68.
STATION	M/A station (basic), FC 21; M/A station (cascade), FC 22; M/A station (ratio), FC 23; and control station, FC 80.

NOTE:

1. Information reported by these function codes can be incorporated into any display. This information is not restricted to faceplate symbols only.

Figure 9-1 is an example group display containing the standard faceplate symbols for each type of control tag.

Control Actions

Control is initiated from a control element (i.e., faceplate). To initiate control, a faceplate element must first be enabled for active control. Pop up elements are automatically enabled for control when called to a display.

Only one element can be selected for control. To enable an element for control, either enter the faceplate selector from the keyboard or activate a touch point. A **TARGET:** prompt for control appears when an element is first selected. To disable control of the currently selected element, press **ESC** or select another element.

Control can be performed using either the keyboard, push-button display elements (**ei 107,115**), or a touch pad, if enabled. The push-button display elements and touchpad

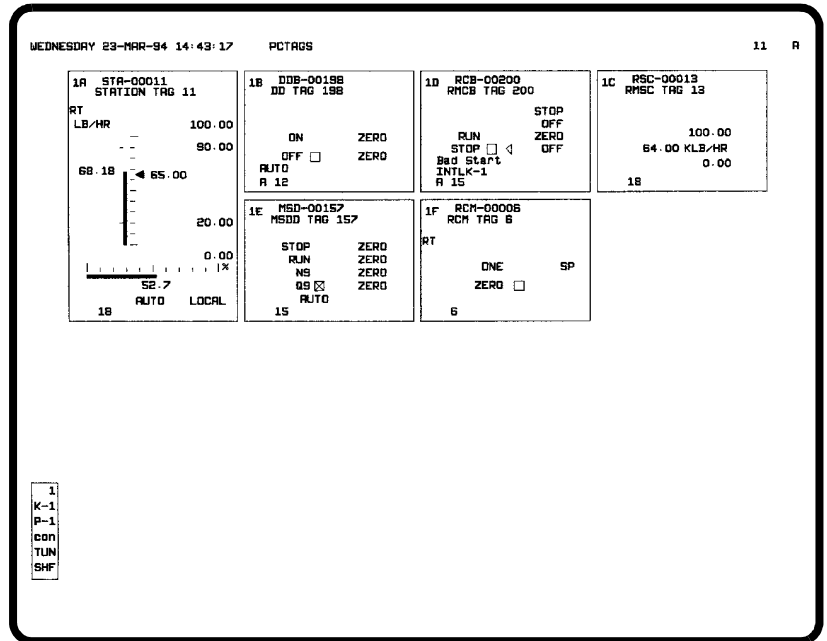

TPS0027C

Figure 9-1. Standard Process Control Faceplate Symbols

keys emulate keys found on the keyboard. Refer to **TOUCH PAD** in Section 8 for a description of the touch pads.

If the *Control Acknowledgment Required* field is enabled during system configuration, an action must be acknowledged by pressing **ENTER** before it is performed. In some cases, such as ramping a value, the display will update but the actual change to the process will not take place until acknowledged.

If the push-button display element (**ei 107,115**) is used the *Enable Control from Pointing Device* operator control option field must be set to **YES**.

Control Inhibit

Control can be inhibited at the module level. This prevents control changes from the console. The inhibit status is checked when a control action is initiated. If inhibited, an invalid action message appears. Table 9-2 shows the inhibit indications that appear for control tags.

Common Control Element Attributes

The standard faceplate elements shown in Figure 9-1 share some common attributes:

- Alarm status/quality/group.
- Control prompt/field.
- Faceplate selector.

Table 9-2. Control Inhibit Indications (Control Tags)

Tag	Inhibit Indication
DD	REMOTE
MSDD	AUTO
RCM	NP
RMCB	Zero state permissives
RMSC	T
STATION	COTR (control output change inhibit) LOCK (mode change inhibit) SPTR (set point change inhibit).

- Red tag descriptor.
- Tag descriptor.
- Tag name.

These attributes can be incorporated into any graphic or custom faceplate.

Alarm Status/Quality/ Group

An alarm status/quality/group field displays alarm status and is used for alarm processing. In standard faceplate symbols, this field accommodates five characters.

From left to right, the first two character positions are the alarm status. A descriptor in these positions identifies the last alarm threshold that a point passed as determined and exception reported by the PCU module. Refer to **ALARM STATUS DESCRIPTORS** in Section 12 for a description of the alarm indications that can appear in this field.

The third character position is the quality field. This field identifies the quality associated with a process value or state and the operating status for the tag. Refer to **QUALITY INDICATORS** in Section 12 for a description of the quality indications that can appear in this field.

NOTES:

1. Operator actions on the console trigger disestablished, substitute, and inhibit status indications (i.e., operating parameters functions). PCU modules report good, suspect, and bad in exception reports.
2. Control cannot be performed for any tag reporting bad quality or off scan.

The last two character positions identify the alarm group to which the tag is assigned. The field appears as either blank for no alarm group or 1 through 99.

Example: An alarm status/quality/group field appears as:

2H 10

This indicates the point has passed the two-high threshold set in the PCU module, the module has determined that it is receiving good data for the point, and the tag defining the process point is part of alarm group ten.

Refer to [Section 12](#) for an explanation of alarm processing, alarm conditions, and alarm indications.

Control Prompt/Field A control prompt/field appears only after selecting an element for control. It consists of a *TARGET:* prompt and an input field. Depending on the tag being controlled, it shows the current mode, state, or value of the selected control point when it first appears. It then allows changing the mode, state, or value from the keyboard. When a change is initiated, the display updates to reflect the target mode, state, or value. The target is the desired change. After a change is actually made in the PCU module, the element updates to verify the change.

The *TARGET:* prompt may appear somewhere other than directly with a display element. The location of the prompt depends on the control select option enabled for the element during its creation.

Faceplate Selector A faceplate selector is one or two alphanumeric characters used to select an element for control. The selector characters identify the keyboard keys that must be pressed to enable the element. After pressing the keys, the outline of the element highlights to verify selection and to easily recognize the element as being enabled. The control keys function for an enabled element only.

Red Tag Descriptor A red tag descriptor (*RT*) identifies a process point as being red tagged. Red tagging performed from the console does **not** prevent a process device from operating. The console can be set up to either display red tag status and disable control actions from the console or to display red tag status only.

A PCU module reports red tag status in an exception report. Red tag status is available for the following control tags:

DD	RMCB
MSDD	STATION
RCM	

Tag Descriptor A tag descriptor can be up to 32 characters and is defined during tag configuration. Normally, this descriptor explains the purpose of the tag (process point).

Tag Name A tag name can be up to 14 characters and is defined during tag configuration. This identifies the tag defined to allow monitoring and control of the process point.

Loop Control

A station faceplate element allows adjusting a control loop. Both a STATION tag defined for the station function block controlling the loop and a station faceplate element are required for loop control. The tag and faceplate element allow monitoring and taking control of the loop from the console.

STATION ELEMENT

A station element is a representation of an analog control station. The same functions that can be performed and the same values that can be displayed on an analog control station physically located in the plant can be performed and displayed on the console using this faceplate element. The station element presents a detailed on-line display of a single process loop. A STATION tag is required to acquire process values from a manual/auto (M/A) station block in a PCU module and to direct control.

Figure 9-2 details the information presented in a station element. The figure describes the elements of the **DCSFULL2.DT** symbol file. Refer to Table 4-1 for a list of symbol files that can be used for a station.

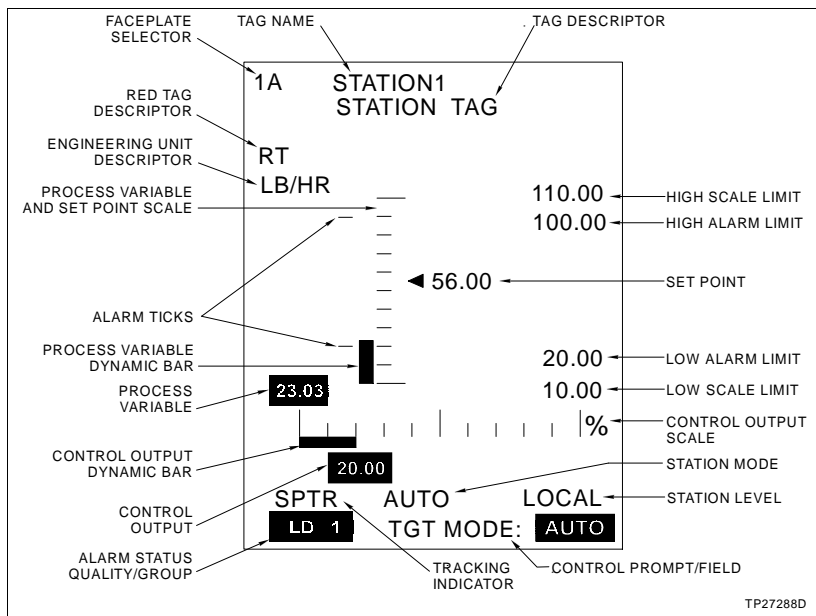

Figure 9-2. Control Station Element

The station block level (local or computer) and mode (manual or auto, and basic, cascade, or ratio) determines the operations that can be performed from the console. The level and mode can be changed from the console.

A station function block exception reports the dynamic values, mode, alarm status, and quality that display in a station element. The following information explains the attributes that relate to a STATION tag and can be incorporated into any graphic or custom faceplate. Figure 9-2 shows the location of the attributes described.

Alarm Tick Marks	The alarm tick marks provide a scale reference to easily determine when the PV dynamic bar passes an alarm limit. These tick marks are positioned at the high and low alarm limit points.
Control Output Dynamic Bar	The control output (CO) dynamic bar shows the control output as an expanding or contracting dynamic bar. The bar expands horizontally from the baseline mark on the scale as the control output increases in percentage and contracts back to the baseline mark as the control output decreases.
Control Output Scale	The CO scale is a static display element used for reference. It is built as a fixed part of the element.
Control Output Value	The CO value is the current value (in percent of output) being output from the station function block. The control output can be adjusted from the console.
Engineering Unit Descriptor	The engineering unit descriptor (EUD) shows the unit of measurement for the process variable and set point. The station function block reports an EUD index number to select the appropriate engineering unit descriptor. Station elements that present the process variable and set point values are in this unit of measurement.
High and Low Alarm Limits	The high and low alarm limits are the maximum and minimum alarm level thresholds. These values are set in the station function block. If the process variable reaches or passes either the high or low alarm limit, the station is in an alarm condition. These limits are monitored to trigger alarm indications.
High and Low Scale Limits	The high and low scale limits are the maximum and minimum value associated with the top line and baseline of the static scale respectively. The limits are derived from the zero and span configured in the station function block for either the process variable or the set point depending on the station element configuration.
Process Variable and Set Point Scale	The process variable (PV) and set point (SP) scale is a static display element used for reference. It is built as a fixed part of the element.
Process Variable Dynamic Bar	The PV dynamic bar shows the process variable as an expanding or contracting dynamic bar. The bar expands vertically from the baseline mark on the scale as the process variable increases in value and contracts back to the baseline mark as the variable decreases.

Process Variable Value The PV value is the current input value being exception reported by the station function block. The process variable comes from the function block providing station block control, usually a PID block.

Set Point Value The SP value is a dynamic moving value accompanied by a dynamic pointer. The displayed value and the pointer position on the scale indicate the current set point being exception reported by the station function block. The set point can be adjusted from the console.

Station Level The station level indicates which type of device is directing the loop control. A station block can operate in either PCU level (local) or computer level control. The level indicators are:

LOCAL - station under PCU local control. The station must be in local level control to allow changes from the console.

CMPTR - station under computer control. When in computer level control, the loop cannot be adjusted from the console.

Station Mode The station mode is the current operating condition for the station. The station operates in either manual or automatic mode. It also operates in basic, cascade, or ratio mode.

When in automatic mode operation, the station mode appears as *AUTO*. In this mode, the PCU module automatically controls the process. The station can be set to either cascade or ratio operation and the set point and ratio index value can be adjusted while in this mode. Whether a station block can be toggled between basic and ratio operation or basic and cascade operation depends on the type of station block. The station mode field indicates *RATIO* or *CASC* if either is selected.

When in manual mode operation, the station mode appears as *MANUAL*. The control output value can be adjusted while in this mode.

Table 9-3 lists the indicators that can appear in the station mode field. The type of indication depends on the escape command used during station element creation.

Table 9-3. Station Modes

Mode	Description
AUTO	Automatic mode operation. The set point and ratio index can be adjusted from the console.
MANUAL	Manual mode operation. The control output can be adjusted from the console.
BYPASS	Bypass mode operation. Control cannot be initiated from the console.
CASC	Cascade operation. Press CASCADE to toggle between basic and cascade operation.

Table 9-3. Station Modes (continued)

Mode	Description
RATIO	Ratio operation. Press RATIO to toggle between basic and ratio operation. Ratio index can be changed while in this mode.
/C	Indicates a cascade station. The mode appears, for example, as <i>AUTO/C</i> or <i>MAN/C</i> . NOTE: The /C also appears with a tracking indicator if a separate tracking indicator field is not used in the element. For example: <i>LOCK/C</i>
/R	Indicates a ratio station. The mode appears, for example, as <i>AUTO/R</i> or <i>MAN/R</i> . NOTE: The /R also appears with a tracking indicator if a separate tracking indicator field is not used in the element. For example: <i>SPTR/R</i>

NOTE: A station element may not have a separate station mode field and tracking indicator field. Depending on the escape commands used during faceplate creation, the element may display both the tracking and mode indicators in the station mode field.

Tracking Indicator

The tracking indicator shows the type of tracking being implemented by the station function block. A station block can employ either control output or set point tracking. Whenever a reference signal to track increases or decreases, the station set point or control output value will follow with tracking enabled. Also, this field identifies a set condition for the manual mode interlock in the station function block.

CO tracking - a control output track lock is set by the control logic. A track lock stays in effect until the logic unlocks the tracking. If the station goes into *COTR* mode (Table 9-4), the control output percentage adjusts to changes in its reference signal to track. Control output changes cannot be initiated from the console when the station is in *COTR* mode.

Table 9-4. Tracking Indicators

Mode	Description
COTR	Control output tracking enabled. OUT does not function.
SPTR	Set point tracking enabled. SET does not function.
LOCK	Manual interlock enabled. MAN/AUTO does not function. The station is locked in <i>MANUAL</i> mode. The manual interlock holds the station in manual mode preventing any automatic mode operations. Only control output can be adjusted while in <i>MANUAL</i> mode.
Blank	No tracking or manual interlock implemented.

NOTE: A station element may not have a separate station mode field and tracking indicator field. Depending on the escape commands used during faceplate creation, the element may display both the tracking and mode indicators in the station mode field.

SP tracking - the set point tracks either the process variable or a selected variable when set point tracking is enabled. The set point tracking option chosen in the station function block determines when set point tracking is implemented. If the station is in *SPTR* mode (Table 9-4), the set point cannot be adjusted from the console. The set point tracking option can be changed by using PCU management or block details tuning functions while a PCU module is in execute mode.

Manual interlock - the manual mode interlock holds the station in *MANUAL* mode (Table 9-4). This is set by the control logic. Until the control logic releases the lockout, the station stays locked and the mode cannot be changed from the console.

STATION CONTROL

There are three types of stations, each controllable from the console: Basic, cascade, and ratio. A basic station generates a set point and provides manual or automatic transfers, allows control output adjustment in manual control mode, and allows set point adjustment in either automatic or manual control mode. A cascade station provides the same functions as a basic station plus an additional cascade mode that allows the set point to be controlled by another process variable. A ratio station also provides the same functions as a basic station, but differs in its method of set point generation. A ratio adjustment factor determines the set point as a ratio of a second uncontrolled (wild) variable. The station can be put into ratio mode from the console to adjust the ratio factor. Any type of station function block can operate as a basic station.

Station control allows changing the mode, set point, ratio index, and control output of a control station by manipulating a station function block in a PCU module.

Enabling Station Control

To **enable** a STATION element for control, either enter its faceplate selector from the keyboard or activate its touch point. A *TGT MODE*: prompt appears when the station element is first selected.

A tuning, block details, or operating parameters display can be called by pressing **TUNE**, **DETAILS**, or **OP PARAMS** while the station element is active. Refer to **BLOCK DETAILS** and **TUNING DISPLAY** in Section 11 for an explanation of the functions performed by using these displays. Refer to **OPERATING PARAMETERS** in Section 13 for an explanation of the operating parameters display and its functions.

To **disable** control of the currently selected station, press **ESC** or select another element.

Changing the Control Level

The control level determines the device that directs the loop control. The station must be in *LOCAL* level control to allow PCU automatic loop control and to initiate changes from the console. A computer directs control when in *CMPTR* mode.

Press **CMPTR** to toggle the station between computer and local control. The *TGT MODE:* field indicates the targeted level and the station level field will update when the change is made.

Changing the Mode

A mode change may be required to perform a desired control action. The station must be in *MANUAL* control mode to adjust the control output. It must be in *AUTO* mode to toggle the station to ratio or cascade operation.

Press **MAN/AUTO** to toggle between manual and automatic mode. The station cannot be toggled to automatic mode if the manual interlock is set (*LOCK*).

Press **CASCADE** while the station is in *AUTO* mode to toggle between basic and cascade operation. The station function block must be capable of cascade operation for this key to function for the station.

Press **RATIO** while the station is in *AUTO* mode to toggle between basic and ratio operation. The station function block must be capable of ratio operation for this key to function for the station.

The *TGT MODE:* field indicates the targeted mode change and the station mode field will update when the change is made.

Changing the Set Point

The set point can be adjusted as long as set point tracking is not enabled. To change the set point:

1. Verify the station is **not** in set point track mode (*SPTR*). The station function block determines in which station modes set point tracking is to be implemented. The choices are to implement set point tracking in manual mode only or to implement it in both automatic and manual mode.
2. Press **SET**. This calls the current set point value and displays it in the TRGT SET field. The engineering unit descriptor gives the unit of measurement associated with this value.
3. The value can be changed using one of two methods. Key in the desired set point target value and press **ENTER** or press the ramp keys to increment or decrement the value.



Performs a slow, ramping set point change. This changes the value 0.2 percent per key-stroke.



Performs a fast, ramping set point change. This changes the value 4.0 percent per key-stroke.

The dynamic pointer will move up or down the scale to reflect the entered value. Press **ESC** to exit without making any changes.

Changing the Ratio Index

The ratio index can be changed while the station is in *RATIO* mode. To change the ratio index:

1. Verify the station is in ratio control mode (*RATIO*). If not, change the mode.
2. If the current ratio index is not displayed in the TRGT RAT: field press **SET**.
3. The value can be changed using one of two methods. Key in the desired ratio index target value and press **ENTER** or press the ramp keys to increment or decrement the value.



Performs a slow, ramping ratio index change. This changes the value 0.2 percent per key-stroke.





Performs a fast, ramping ratio index change. This changes the value 4.0 percent per key-stroke.



Press **ESC** to exit without making any changes.

Changing the Control Output

The control output can be changed while the station is in *MANUAL* mode. To change the control output:

1. Verify the station is in manual control mode (*MANUAL*). If not, change the mode.
2. If the current output values is not displayed in the TRGT OUT field press **OUT**. The value is in percent of output.
3. The value can be changed using one of two methods. Key in the desired output target value and press **ENTER** or press the ramp keys to increment or decrement the value.

  Performs a slow, ramping control output change. This changes the value 0.2 percent per keystroke.

  Performs a fast, ramping control output change. This changes the value 4.0 percent per keystroke.

The dynamic bar will expand or contract to reflect the entered value. Press **ESC** to exit without making any changes.

Device Control

The console gives the ability to access process devices distributed throughout the entire system. After gaining access to a process device, its status can be displayed and the device can be controlled from the console.

A process device is controlled by manipulating the control configuration in the PCU module. The faceplate elements used for device control give feedback to verify when changes requested from the console are actually implemented by a device.

REMOTE CONTROL MEMORY ELEMENT

The remote control memory (RCM) element represents a remote control memory function block in a PCU module. This function block provides a set and reset, flip-flop memory to control a process device. An RCM tag is required to monitor and control the output of this function block.

Figure 9-3 details the information presented in a remote control memory element. The figure describes the elements of the **RCM1.DT** symbol file. Refer to Table 4-1 for a list of symbol files that can be used for a remote control memory.

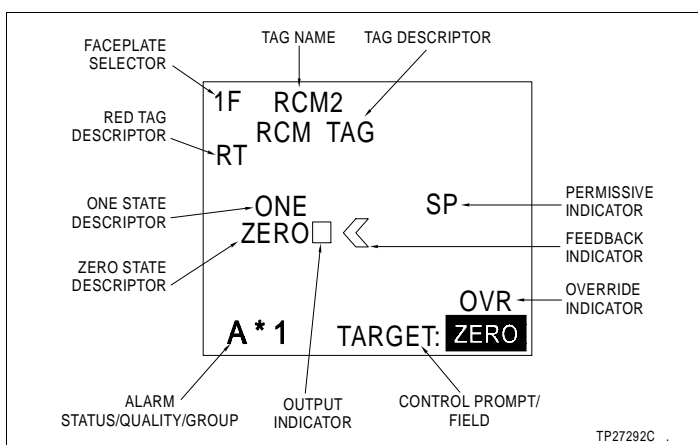

Figure 9-3. Remote Control Memory Element

The remote control memory block exception reports the current state, feedback state, permissive state, override status, alarm status, and quality presented in the RCM element. The following information explains the attributes that relate to an RCM tag and can be incorporated into any graphic or custom faceplate. Figure 9-3 shows the location of the attributes described.

Feedback Indicator	The feedback indicator gives a feedback indication to verify the change in state of a device and to show its current output state. The arrow positions at either the one or zero state as soon as feedback is returned.
One State Descriptor	The one state descriptor is text that describes a one state (logic one) output of the RCM function block. This descriptor is the <i>ONE</i> state descriptor defined in the database for the tag.
Output Indicator	The output indicator position identifies the requested logic state to be output by the RCM block. For example, the output is a logic one when it is next to the one state descriptor.
Override Indicator	The override indicator identifies an override condition. An override occurs when the RCM function block is permissive and there is a conflict between the set and reset inputs to the function block. The output tracks an alternate input if the set and reset signals are both logic one simultaneously.
Permissive Indicator	The permissive indicator shows the status being reported as the permissive input to the function block. The block must be in a permissive state to change the RCM function block to its one state (set). An <i>SP</i> identifies the RCM as being set to permissive. An <i>NP</i> indicates nonpermissive.
Zero State Descriptor	The zero state descriptor is text that describes a zero state (logic zero) output of the RCM function block. This descriptor is the <i>ZERO</i> state descriptor defined in the database for the tag.

RCM CONTROL

RCM control allows changing the output of a remote control memory function block in a PCU module. The remote control memory block provides a set and reset signal to a process device. The RCM function block acts on one of two inputs to develop its output. The block accepts both a control configuration driven input and an input from the console.

The two inputs are also differentiated by the type of input. The control configuration can initiate either a pulsed or sustained command to the block where the console can only input a pulsed command. A sustained input, which remains in a set logic state, overrides any pulsed input. A pulsed input is a one-cycle transition used to trigger a state change. In either

case, the block maintains its current output even if the input is removed. The output remains in either a set or reset state until another command is received to change the output state.

A pulsed set command from the console causes the block to output a logic one and a pulsed reset command causes a logic zero output. This occurs as long as the control logic is not providing a sustained input to the block. A change to the one state (set) can only occur when the RCM function block is set to permissive.

Enabling RCM Control

To **enable** an RCM element to control a remote control memory function block, either enter its faceplate selector from the keyboard or activate its touch point. A **TARGET:** prompt appears when the element is first selected.

A block details or operating parameters display can be called by pressing **DETAILS** or **OP PARAMS** while the RCM element is active. Refer to **BLOCK DETAILS** in Section 11 for an explanation of the functions performed by using the block details display. Refer to **OPERATING PARAMETERS** in Section 13 for an explanation of the operating parameters display and its functions.

To **disable** control of the currently selected element, press **ESC** or select another element.

Changing the Output State

The RCM function block output can only be changed from the console if the block is not in an override (**OVR**) or nonpermissive (**NP**) condition. The block must be set to permissive (**SP**) to change the state.

To change remote control memory output, press:

- One state output.
- Zero state output.

The **TARGET:** field indicates the targeted change and the output indicator will move to reflect the change. The feedback indicator will update after feedback is received from the process.

REMOTE MANUAL SET CONSTANT ELEMENT

The remote manual set constant (RMSC) element represents a remote manual set constant function block in a PCU module. This function block inserts a constant value used in the

process control configuration. An RMSC tag is required to both monitor and change the constant value provided by the block from the console.

Figure 9-4 details the information presented in a remote manual set constant element. The figure describes the elements of the **RMSC1.DT** symbol file. Refer to Table 4-1 for a list of symbol files that can be used for a remote manual set constant.

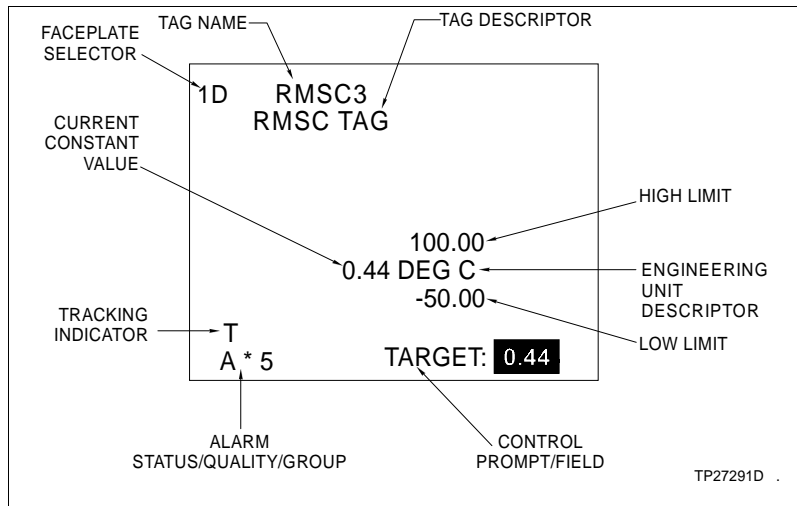

Figure 9-4. Remote Manual Set Constant Element

The remote manual set constant block exception reports the constant value, high and low limits, tracking, alarm status, and quality that display in the RMSC element. The following information explains the attributes that relate to an RMSC tag and can be incorporated into any graphic or custom faceplate. Figure 9-4 shows the location of the attributes described.

Current Constant Value

The current constant value is the value that is currently set and is being reported as the constant value in the RMSC block. This value can be changed from the console.

Engineering Unit Descriptor

The engineering unit descriptor (EUD) shows the unit of measurement for the constant value. The RMSC function block reports an EUD index number to select the appropriate engineering unit descriptor.

High and Low Limits

The high and low limits are the maximum and minimum acceptable values. Only values that fall within this maximum and minimum range can be entered. An attempt to enter a value outside these limits causes an error message prompt.

Tracking Indicator

The tracking indicator appears when an RMSC block has been set to tracking mode. The control logic can force the block to track an alternate process variable. A *T* displays to identify tracking mode. The value cannot be changed when the block is tracking.

RMSC CONTROL

RMSC control allows changing a constant value in a remote manual set constant function block while a PCU module is in execute mode. A new value can be entered at any time except when the *T* (tracking) indicator is present.

Enabling RMSC Control

To **enable** an RMSC element to change the constant value of a remote manual set constant block, either enter its faceplate selector from the keyboard or activate its touch point. A *TARGET:* prompt appears when the element is first selected.

A block details or operating parameters display can be called by pressing **DETAILS** or **OP PARAMS** while the RMSC element is active. Refer to **BLOCK DETAILS** in Section 11 for an explanation of the functions performed by using the block details display. Refer to **OPERATING PARAMETERS** in Section 13 for an explanation of the operating parameters display and its functions.

To **disable** control of the currently selected element, press **ESC** or select another element.

Changing the Value

The RMSC block value cannot be changed while the block is in tracking (*T*) mode. To enter a new value:

1. If the current value of the constant is not displayed in the *TARGET:* field press **SET**
2. The value can be changed using one of two methods. Key in a desired target value and press **ENTER** or press the ramp keys to increment or decrement the value.



Performs a slow, ramping change. This changes the value 0.2 percent per keystroke.



Performs a fast, ramping change. This changes the value 4.0 percent per keystroke.

The RMSC function block will not accept a value that is outside the high and low limits. When entering or ramping the value, the *TARGET* field is updated to reflect the change. Press **ESC** to exit without making any changes.

DEVICE DRIVER ELEMENT

The device driver (DD) element represents a device driver function block in a PCU module. This function block provides an

on or off signal to control a process device. A DD tag is required to both monitor and change the output provided by the block from the console.

Figure 9-5 details the information presented in a device driver element. The figure describes the elements of the **DEVDR1.DT** symbol file. Refer to Table 4-1 for a list of symbol files that can be used for a device driver.

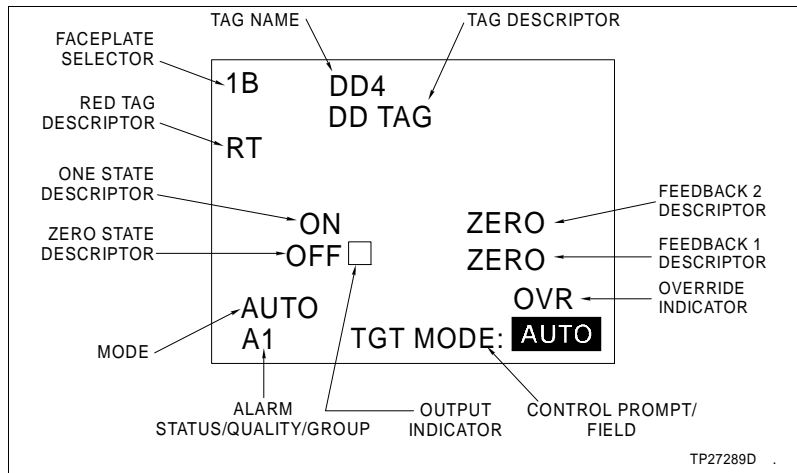

Figure 9-5. Device Driver Element

The device driver block exception reports the current state, two feedback states, override status, mode, alarm status, and quality that display in the DD element. The following information explains the attributes that relate to a DD tag and can be incorporated into any graphic or custom faceplate. Figure 9-5 shows the location of the attributes described.

Feedback Descriptors

The feedback one and two descriptors are text that describe the feedback signals input to the DD function block. The feedbacks will indicate either an on (logic one) or off (logic zero) state. The element displays the *ZERO* and *ONE* descriptors defined in the database for feedback one and two.

The feedback indications provide a verification of the actual state of the field device. When a change is initiated, the descriptors do not change until the block tests the feedback inputs. This does not occur until after a specified time elapses. The DD block also tests the feedback signals to determine if the output status is either good or bad.

Mode

The mode shows the current operating condition of the block. A device driver block can be configured to operate in automatic mode only, automatic and manual mode, or remote mode only. The device driver function block specifications determine the acceptable operating modes.

While in *AUTO* mode, the control logic sets the output state of the device driver block. The block only provides an update to the display. *MANUAL* mode allows changing the output state from the console. If the DD block is in *REMOTE* control mode, state changes cannot be initiated from the console. The block output tracks the value of another function block in the process control configuration.

One State Descriptor	The one state descriptor is text that describes a one state (logic one) output of the DD function block. This descriptor is the <i>ONE</i> state descriptor defined in the database for the tag.
Output Indicator	The output indicator position identifies the requested logic state to be output by the DD block. For example, the output is a logic one when it is next to the one state descriptor.
Override Indicator	The override indicator identifies an override condition. Normally, the device driver block determines the output status by comparing the feedback signals to an expected condition defined in its configuration. An <i>OVR</i> indication occurs when the DD block is set to override its reported output status. The override forces the status to zero (good).
Zero State Descriptor	The zero state descriptor is text that describes a zero state (logic zero) output of the DD function block. This descriptor is the <i>ZERO</i> state descriptor defined in the database for the tag.

DD CONTROL

DD control allows manually changing the output of a device driver function block in a PCU module. The device driver block provides an on or off signal to a process device.

The DD function block can develop its outputs based on control logic or an input from the console. Or, it can be unconditionally set with interlock logic. The function block specifications determine which will occur. The operating modes also depend on this selection. The block can be set to allow automatic mode only, automatic and manual mode, or remote mode only.

Enabling DD Control

To **enable** a DD element to control a device driver function block, either enter its faceplate selector from the keyboard or activate its touch point. A *TGT MODE:* prompt appears when the element is first selected.

A block details or operating parameters display can be called by pressing **DETAILS** or **OP PARAMS** while the DD element is active. Refer to **BLOCK DETAILS** in Section 11 for an explanation of the functions performed by using the block details display. Refer to **OPERATING PARAMETERS** in Section 13

for an explanation of the operating parameters display and its functions.

To **disable** control of the currently selected element, press **ESC** or select another element.

Changing the Output State

The DD block output cannot be changed while the block is in *REMOTE* mode. Manual mode control may or may not be permitted while the block is in an override (*OVR*) condition. This depends on the device driver block specifications.

To change the device driver output:

1. Press **MAN/AUTO** to toggle to *MANUAL* mode.
2. Press:

- One state output.
- Zero state output.

The *TARGET:* field indicates the targeted change and the output indicator will move to reflect the change. The feedback descriptors will update after receiving feedback from the process.

MULTI-STATE DEVICE DRIVER ELEMENT

The multi-state device driver (MSDD) element represents a multi-state device driver function block in a PCU module. This function block has three separate output conditions to provide three state process device control. An MSDD tag is required to both monitor and change the output provided by the block from the console.

Figure 9-6 details the information presented in a device driver element. The figure describes the elements of the **MSDEVDR1.DT** symbol file. Refer to Table 4-1 for a list of symbol files that can be used for a multi-state device driver.

The multi-state device driver block exception reports the current state, four feedback states, override status, mode, alarm status, and quality presented in the MSDD element. The following information explains the attributes that relate to an MSDD tag and can be incorporated into any graphic or custom faceplate. Figure 9-6 shows the location of the attributes described.

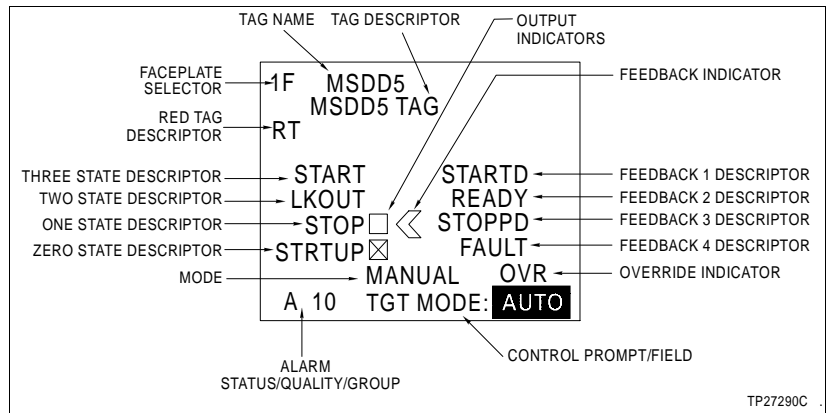

Figure 9-6. Multi-State Device Driver Element

Feedback Descriptors

The feedback one, two, three, and four descriptors are text that describe the feedback signals input to the MSDD function block. The feedbacks will indicate either an on (logic one) or off (logic zero) state. The element displays the *ZERO* and *ONE* descriptors defined in the database for feedback one through four.

The feedback indications provide a verification of the actual status of the field device. The MSDD block uses the feedback signals to determine if the output status is either good or bad.

Feedback Indicator

The feedback indicator position identifies the current output based on feedback from the process. When a change is initiated, the indicator maintains its position until a specified time elapses before testing the feedback inputs. After the time elapses, the indicator positions on the appropriate state based on the feedback.

Mode

The mode shows the current operating condition of the block. A multi-state device driver block can be configured to operate in automatic mode only or automatic and manual mode. The MSDD function block specifications determine the acceptable operating modes.

While in *AUTO* mode, the control logic sets the output state of the multi-state device driver block. The block only provides an update to the display. *MANUAL* mode allows changing the output state from the console.

One State Descriptor

The one state descriptor is text that describes a one state (output mask one) output of the MSDD function block. This descriptor is the *ONE* state descriptor defined in the database for the tag.

Output Indicator

The output indicator position identifies the requested output of the MSDD block. For example, the requested output is output mask three when next to the three state descriptor. Refer

to **MSDD CONTROL** in this section for an explanation of output masks.

Override Indicator	The override indicator identifies an override condition. Normally, the multi-state device driver block determines the output status by comparing the feedback signals to an expected condition defined in its configuration. An <i>OVR</i> indication occurs when the MSDD block is set to override its reported output status. The override forces the status to zero (good). The MSDD can be configured to default to a specific mode and output when in an override condition.
Three State Descriptor	The three state descriptor is text that describes a three state (output mask three) output of the MSDD function block. This descriptor is the <i>THREE</i> state descriptor defined in the database for the tag.
Two State Descriptor	The two state descriptor is text that describes a two state (output mask two) output of the MSDD function block. This descriptor is the <i>TWO</i> state descriptor defined in the database for the tag.
Zero State Descriptor	The zero state descriptor is text that describes a zero state (default mask) output of the MSDD function block. This descriptor is the <i>ZERO</i> state descriptor defined in the database for the tag.

MSDD CONTROL

MSDD control allows manually changing the output of the multi-state device driver function block in a PCU module. The multi-state device driver block provides three state control for a process device.

The MSDD function block can develop its outputs based on control logic or an input from the console. In *AUTO* mode, two digital inputs from the control configuration select a mask that drives the outputs. In *MANUAL* mode, output masks are selected by pressing certain keys on the console. The function block can be set to allow automatic mode only or both automatic and manual mode.

Four separate output masks defined in the MSDD configuration determines the control output signals that are sent to a process device. Each mask, defined as a three-bit code, specifies the state of each of three MSDD block outputs. A specific output mask is selected by two inputs to the block.

Enabling MSDD Control

To **enable** an MSDD element to control a multi-state device driver function block, either enter its faceplate selector from

the keyboard or activate its touch point. A *TGT MODE:* prompt appears when the element is first selected.

A block details or operating parameters display can be called by pressing **DETAILS** or **OP PARAMS** while the MSDD element is active. Refer to **BLOCK DETAILS** in Section 11 for an explanation of the functions performed by using the block details display. Refer to **OPERATING PARAMETERS** in Section 13 for an explanation of the operating parameters display and its functions.

To **disable** control of the currently selected element, press **ESC** or select another element.

Changing the Output State

The MSDD block output cannot be changed while the block is in automatic (*AUTO*) mode. Manual mode control may or may not be permitted while the block is in an override (*OVR*) condition. This depends on the multi-state device driver block specifications.

To change the multi-state device driver output:

1. Press **MAN/AUTO** to toggle to *MANUAL* mode.

2. Press:

- Three state outputs (output mask three).
- Two state outputs (output mask two).
- One state outputs (output mask one).

The *TARGET:* field indicates the targeted change and the output indicator will move to reflect the change. The feedback descriptors and indicator will update after receiving feedback from the process.

The MSDD function block may be set up to prevent random output changes while in *MANUAL* mode. This prevents accidental upsets to the process. In this case, a sequence defined in the function block must be followed. The block identifies which output states can be selected based on the current output state.

REMOTE MOTOR CONTROL BLOCK ELEMENT

The remote motor control block (RMCB) element represents a remote motor control function block in a PCU module. This function block implements a start and stop logic sequence to

direct the start-up or shutdown of a process device. An RMCB tag is required to both monitor and change the output provided by the block from the console.

Figure 9-7 details the information presented in a remote motor control block element. The figure describes the elements of the **RMCB1.DT** symbol file. Refer to Table 4-1 for a list of symbol files that can be used for a remote control memory.

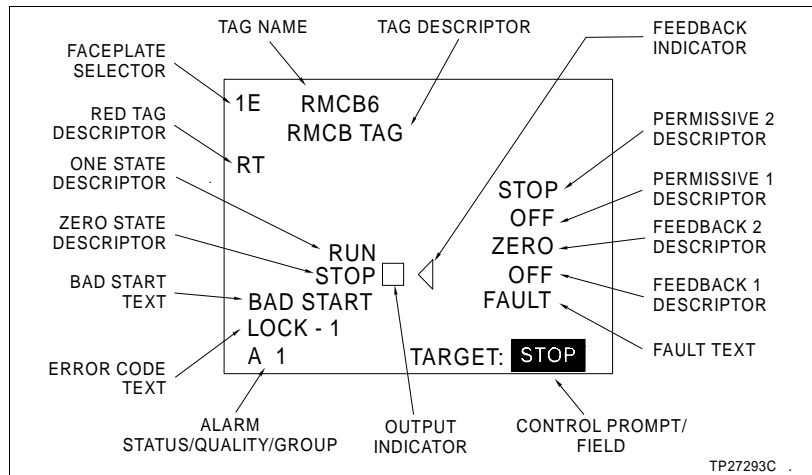

Figure 9-7. Remote Motor Control Block Element

The remote motor control block exception reports the current state, two feedback states, two permissive states, fault status, error code, alarm status, and quality that display in the RMCB element. The following information explains the attributes that relate to an RMCB tag and can be incorporated into any graphic or custom faceplate. Figure 9-7 shows the location of the attributes described.

Bad Start Text The bad start text displays when the RMCB block has detected a bad start of the process device. The block monitors the feedback signals to determine a bad start.

Error Code Text The error code text describes one of ten different error codes that can be reported by the RMCB block:

- 0 - No error.
- 1 - Stopped.
- 2 - Interlock one.
- 3 - Interlock two.
- 4 - Interlock three.
- 5 - Interlock four.
- 6 - Feedback one set to zero state.
- 7 - Feedback two set to zero state.

- 8 - Feedback one set to one state.
- 9 - Feedback two set to one state.

NOTE: The block sends an interlock error code when an interlock is set to a logic zero.

Only one error code displays at a time. A different text string is associated with each error code. A text set that defines a text string for each code must be created before the error text can be displayed. Refer to the discussion on remote motor control text in the **Configuration** instruction for further explanation (Table 1-2 lists instruction numbers).

Fault Text The fault text describes a fault condition being reported by the RMCB function block. A fault occurs when one of four interlock inputs to the block is set to off (or logic zero). All interlocks must be on (or logic one) to clear a fault.

Feedback Descriptors The feedback one and two descriptors are text that describe the feedback signals input to the RMCB function block. The feedbacks will indicate either an on (logic one) or off (logic zero) state. The element displays the *ZERO* and *ONE* descriptors defined in the database for feedback one and two.

The feedback indications provide a verification of the actual status of the device. The RMCB block uses the feedback signals to determine if the output status is either good or alarm. The feedback signals are also used to determine whether to maintain a run output or to force the output to stop.

Feedback Indicator The feedback indicator position identifies the current output based on feedback from the process. When a change is initiated, the indicator maintains its position until a specified time elapses before testing the feedback inputs. After the time elapses, the indicator positions on the appropriate state. Table 9-5 shows the relationship between reported feedback state and feedback indication.

Table 9-5. RMCB Feedback Signal to Feedback Indicator Relationship

FB1 State	FB2 State	One State Indication	Zero State Indication
0	0	blank	hollow
0	1	blank	hollow
1	0	blank	hollow
1	1	filled	blank

One State Descriptor The one state descriptor is text that describes a one state output of the RMCB function block. A one state for the RMCB block sets a device to a running state. This descriptor is the *ONE* state descriptor defined in the database for the tag.

Output Indicator	The output indicator position identifies the currently requested output of the RMCB function block. When next to the one state descriptor, the requested output is run (logic one). The block is set to stop when positioned next to the zero state descriptor.
Permissive Descriptors	The permissive one and two descriptors are text that describe the permissive inputs to the function block. The element displays the <i>ZERO</i> and <i>ONE</i> descriptors defined in the database for permissive one and permissive two. Both permissive inputs to the block must be in a permissive state (one state) to change the RMCB block to its one state (run).
Zero State Descriptor	The zero state descriptor is text that describes a zero state output of the RMCB function block. A zero state for the RMCB block sets a device to a stopped state. This descriptor is the <i>ZERO</i> state descriptor defined in the database for the tag.

RMCB CONTROL

RMCB control allows changing the output of a remote motor control function block in a PCU module. The remote control memory block provides a start and stop signal to a process device. The RMCB function block acts on one of two inputs to develop its output. The block accepts both a control configuration driven input and an input from the console.

Enabling RMCB Control

To **enable** an RMCB element to control a remote motor control function block, either enter its faceplate selector from the keyboard or activate its touch point. A *TARGET:* prompt appears when the element is first selected.

A block details or operating parameters display can be called by pressing **DETAILS** or **OP PARAMS** while the RMCB element is active. Refer to **BLOCK DETAILS** in Section 11 for an explanation of the functions performed by using the block details display. Refer to **OPERATING PARAMETERS** in Section 13 for an explanation of the operating parameters display and its functions.

To **disable** control of the currently selected element, press **ESC** or select another element.

Changing the Output State

The RMCB block can only be changed from the console (or control logic) if the permissive descriptors indicate a permissive state (one state). A *FAULT* must also be cleared before a change can occur. The fault is driven by the state of the interlock inputs.

To change remote motor control block output, press:



One state output (run).



Zero state output (stop).

The *TARGET:* field indicates the targeted change and the output indicator will move to reflect the change. The feedback descriptors and indicator will update after feedback is received from the process. Certain display elements, explained earlier, will update to indicate a bad start if an unsuccessful start-up occurs.

SECTION 10 - DATA ACQUISITION

INTRODUCTION

The console provides data acquisition capabilities to support both process monitoring and control. The console gives access to INFI 90 OPEN process control unit (PCU) modules to acquire then display values or state changes related to process operations.

This section explains the information presented in standard faceplate display elements for data acquisition. These symbols are provided with the console. The procedures and operations explained in this section remain the same for custom faceplates designed to provide the same capabilities although they may not and do not have to include all features if not required. The escape commands defined in a symbol file during creation determine the capabilities of a faceplate. Refer to [Section 4](#) for further explanation.

NOTE: Refer to the *Display Builder Reference* instruction for a description of additional display elements that can be incorporated into a display or a custom faceplate beyond those described in this section (Table 1-2 lists instruction numbers).

DATA ACQUISITION FUNCTIONS

Process information is received in exception reports from function blocks configured in a PCU module. Data acquisition tags allow accessing specific function blocks within the control configuration to display analog values and digital state changes. An analog value can be a process variable such as flow rate, drum level, pressure, temperature, etc. A digital state can be an on or off, set or reset, and start or stop state for a process device. The tags also allow presenting alarm conditions and quality reported by the function blocks. The control ability for data acquisition tags allows changing process conditions from the console by initiating changes to the PCU module.

NOTE: Control abilities can be limited to specific personnel by defining password security. The security level of a user must give control access rights before any control can be initiated.

Data Acquisition Faceplates

Dynamic faceplates for the different types of data acquisition tags can be either standard or user-created. Standard data acquisition elements are provided. A data acquisition element can be a fixed part of a display or it can be called as a pop up element. The same control actions can be performed from a fixed element as can be performed from a pop up element. This

assumes that the symbol file used for the fixed element is also the same one used for the pop up element, or the pop up element, if different, has all the same capabilities as the fixed element built in.

Data Acquisition Tags

Data acquisition tags provide access to data acquisition function blocks within a module. The access can be used to manually initiate changes and to monitor the results of both automatic and manual operations. Automatic refers to operation being performed under PCU module execution. Manual refers to those actions initiated after taking a function block out of automatic PCU control. Table 10-1 lists the data acquisition tags and the function codes (FC) they associate with. Refer to the **Function Code Application Manual** for a description of the data acquisition function codes and their specifications (Table 1-2 lists instruction numbers).

Table 10-1. Data Acquisition Tags

Tag	Function Code ¹
ANALOG	Analog exception report, FC 30, FC 222, FC 223.
DAANALG ²	Control station, FC 21, 22, 23, and 80 or data acquisition analog, FC 177.
DADIG	Data acquisition digital, FC 211.
DADIGTL	Multi-state device driver, FC 129.
DANG	Data acquisition analog, FC 177.
DIGITAL	Digital exception report, FC 45, FC 224, FC 225.
TEXTSTR	User-defined data export, FC 194.

NOTES:

1. Information reported by the data acquisition function codes can be incorporated into any display. This information is not restricted to faceplate symbols only.
2. Does not implement the complete functionality of FC 177.

Figure 10-1 is an example group display containing the standard faceplate symbols used for data acquisition tag types.

Control Actions

Control is initiated from a control element (i.e., faceplate). To initiate control, a faceplate element must first be enabled for active control. Pop up elements are automatically enabled for control when called to a display.

Only one element can be selected for control. To enable an element for control, either enter the faceplate selector from the keyboard or activate a touch point. A *TARGET*: prompt for control appears when an element is first selected. To disable control of the currently selected element, press **ESC** or select another element.

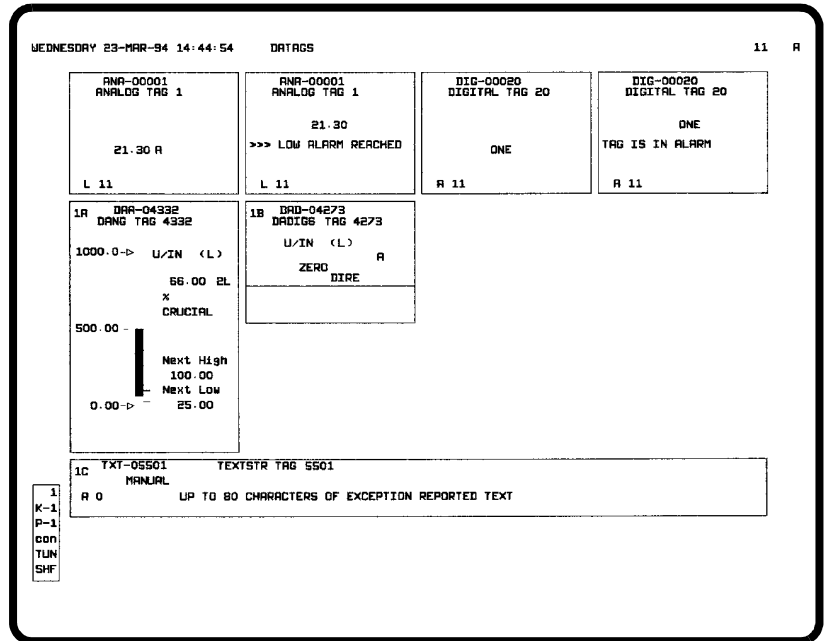

Figure 10-1. Standard Data Acquisition Faceplate Symbols

Control can be performed using either the keyboard, push-button display elements (**ei 107,115**), or a touch pad, if enabled. A touch pad emulates keys found on the keyboard. Refer to **TOUCH PAD** in Section 8 for a description of the touch pads.

If the *Control Acknowledgment Required* field is enabled during system configuration, an action must be acknowledged by pressing **ENTER** before it is performed. In some cases, such as ramping a value, the display will update but the actual change to the process will not take place until acknowledged.

If the push-button display element (**ei 107,115**) is used the *Enable Control from Pointing Device* operator control option field must be set to **YES**.

Control Inhibit

Control can be inhibited at the module level. This prevents control changes from being initiated from the console. The inhibit status is checked when a control action is initiated. If inhibited, an invalid action message appears. Table 10-2 shows the inhibit indications that appear for data acquisition tags.

Common Data Acquisition Element Attributes

The standard faceplate elements shown in Figure 10-1 share some common attributes:

Table 10-2. Control Inhibit Indications
(Data Acquisition Tags)

Tag	Inhibit Indication
DADIG	L
DANG	L
TEXTSTR	USER TEXT LOCK

- Alarm status/quality/group.
- Control prompt/field.
- Faceplate selector.
- Red tag descriptor.
- Tag descriptor.
- Tag name.

These attributes can be incorporated into any graphic or custom faceplate.

Alarm Status/Quality/ Group

An alarm status/quality/group field displays alarm status and is used for alarm processing. In standard faceplate symbols, this field accommodates five characters.

From left to right, the first two character positions are the alarm status. A descriptor in these positions identifies the last alarm threshold that a point passed as determined and exception reported by the PCU control configuration. Refer to **ALARM STATUS DESCRIPTORS** in Section 12 for a description of the alarm indications that can appear in this field.

The DANG, DADIG, and TEXTSTR tags present alarm suppression status in the status position of the alarm status/quality/group field. An **!!** appears when alarm suppression is enabled for the tag.

The third character position is the quality field. This field identifies the quality associated with a process value or state and the operating status for the tag. Refer to **QUALITY INDICATORS** in Section 12 for a description of the quality indications that can appear in this field.

NOTES:

1. Operator actions on the console trigger disestablished, substitute, and inhibit status indications (i.e., operating parameters functions). PCU modules report good, suspect, and bad in exception reports.
2. Control cannot be performed for any tag reporting bad quality or off scan.

The last two character positions identify the alarm group to which the tag is assigned. The field appears as either blank for no alarm group or 1 through 99.

Example: An alarm status/quality/group field appears as:

2H 10

This indicates the point has passed the two-high threshold set in the PCU module, the module has determined that it is receiving good data for the point, and the tag defining the process point is part of alarm group ten.

Refer to [Section 12](#) for an explanation of alarm processing, alarm conditions, and alarm indications.

Control Prompt/Field

A control prompt/field appears only after selecting an element for control. It consists of a *TARGET:* prompt and an input field. Depending on the tag being controlled, it shows the current mode, state, or value of the selected control point when it first appears. It then allows changing the mode, state, or value from the keyboard. When a change is initiated, the display updates to reflect the target mode, state, or value. The target is the desired change. After a change is actually made in the PCU module, the element updates to verify the change.

The *TARGET:* prompt may appear somewhere other than directly with a display element. The prompt location depends on the control select option selected for the element during its creation.

Faceplate Selector

A faceplate selector is one or two alphanumeric characters used to select an element for control. The selector characters identify the keyboard keys that must be pressed to enable the element. After pressing the keys, the outline of the element highlights to verify selection and to easily recognize the element as being enabled. The control keys function for an enabled element only.

Red Tag Descriptor

A red tag descriptor (*RT*) identifies a process point as being red tagged. Red tagging performed from the console does **not** prevent a process device from operating. The console can be set up to either display red tag status and disable control actions from the console or to display red tag status only.

A PCU module reports red tag status in an exception report. Red tag status is available for a DANG, DADIG, or TEXTSTR tag.

Tag Descriptor

A tag descriptor can be up to 32 characters and is defined during tag configuration. Normally, this descriptor explains the purpose of the tag (process point).

Tag Name

A tag name can be up to 14 characters and is defined during tag configuration. This identifies the tag defined to allow monitoring and control of the process point.

Analog Element

This part of the section describes two basic data acquisition faceplate symbols used to present analog tag values.

Figure 10-2 details the information presented in a standard analog element. The figure describes the elements of the **ANALOG1.DT** symbol file. Figure 10-3 details the information presented in an analog annunciator element. The figure describes the elements of the **ANCREAL1.DT** symbol file. Figure 10-4 details the information presented in an analog control element. The figure describes the elements of the **ANLGCTL1.DT** symbol file. Refer to Table 4-1 for a list of symbol files that can be used for an analog.

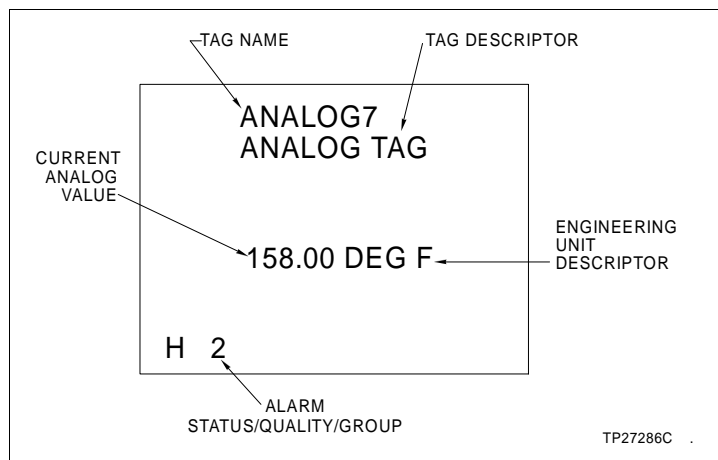

Figure 10-2. Analog Element

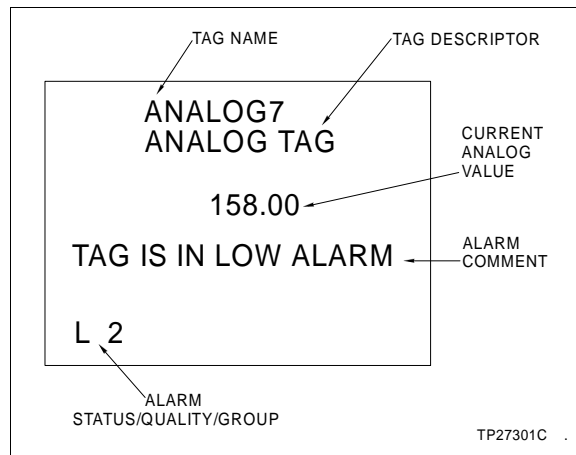

Figure 10-3. Analog Annunciator Element

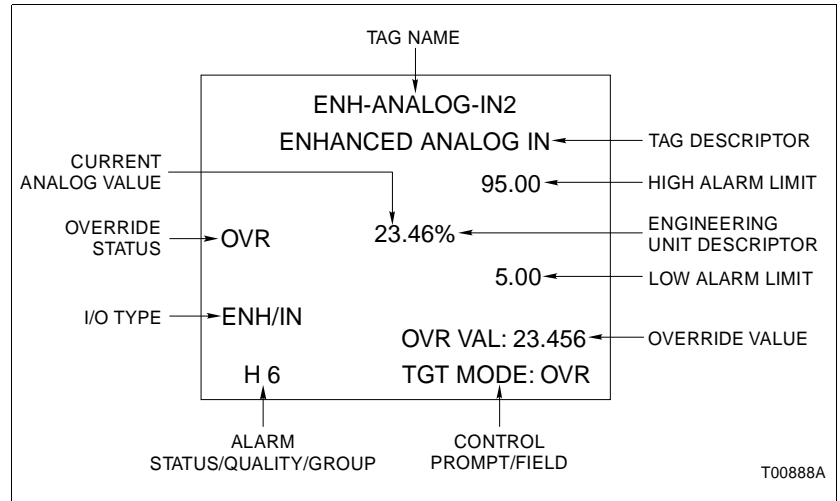

Figure 10-4. Analog Control Element

ANALOG ELEMENT ATTRIBUTES

An analog function block exception reports the current analog value, alarm status, and quality presented in these elements. The following information explains the attributes that relate to an analog type of tag and can be incorporated into any graphic or custom faceplate. Figures 10-2 and 10-3 show the location of the attributes described below.

Alarm Comment

The alarm comment is text that describes an alarm condition. The comment can be up to 64 characters. The comment can describe, for example, the purpose of the alarm indication or operator actions required to correct the alarm. An alarm comment can be defined for each tag alarm condition.

Current Analog Value

The current analog value is the value being exception reported by the analog function block. This value is dynamic and changes as the variable being monitored changes.

Engineering Unit Descriptor

The engineering unit descriptor (EUD) shows the unit of measurement for the analog value. The analog function block reports an EUD index number to select the appropriate engineering unit descriptor.

I/O Type

Indicates the type of analog input or output:

- ENH/IN* I/O block input (FC 222).
- ENH/OUT* I/O block output (FC 223).
- STD* Standard analog (FC 30)

Override Status

The override status (OVR) indicates if the output value is being overridden. When the tag is in normal operation the field is blank.

Override Value The input or output value of the tag is overridden with this value when the override status is enabled.

ANALOG CONTROL

The analog control options allow changing the override status and the override value of the analog control element.

Changing the Override Status

The override status for the ANALOG block can be changed from the console. Press **MAN/AUTO** to toggle between the normal status and the override status.

The *TGT MODE:* field indicates the targeted change.

Changing the Override Value

To change the override value being stored in nonvolatile memory of a PCU module:

1. If the current override value is not displayed in the target prompt press **SET**. The engineering unit descriptor identifies the unit of measurement associated with the value.
2. The value can be changed using one of two methods. Key in the desired target value and press **ENTER** or press the ramp keys to increment or decrement the value. Press **ESC** to exit without making any changes.



Performs a slow, ramping value change. This changes the value 0.2 percent per keystroke.

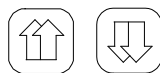

Performs a fast, ramping value change. This changes the value 4.0 percent per keystroke.

Digital Element

This part of the section describes two basic data acquisition faceplate symbols used to present digital states.

Figure 10-5 details the information presented in a standard digital element. The figure describes the elements of the **BOOLEAN1.DT** symbol file. Figure 10-6 details the information presented in a digital annunciator. The figure describes the elements of the **ANCBOOL1.DT** symbol file. Figure 10-7 details the information presented in a digital control element. The figure describes the elements of the **BOOLCTL1.DT** symbol file. Refer to Table 4-1 for a list of symbol files that can be used for a digital.

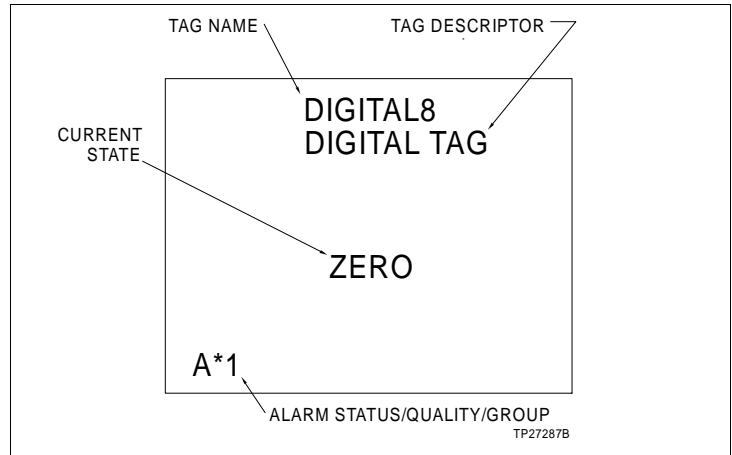

Figure 10-5. Digital Element

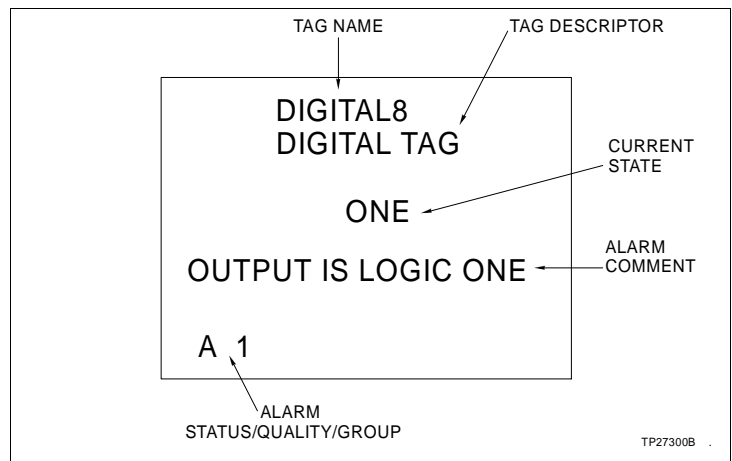

Figure 10-6. Digital Annunciator Element

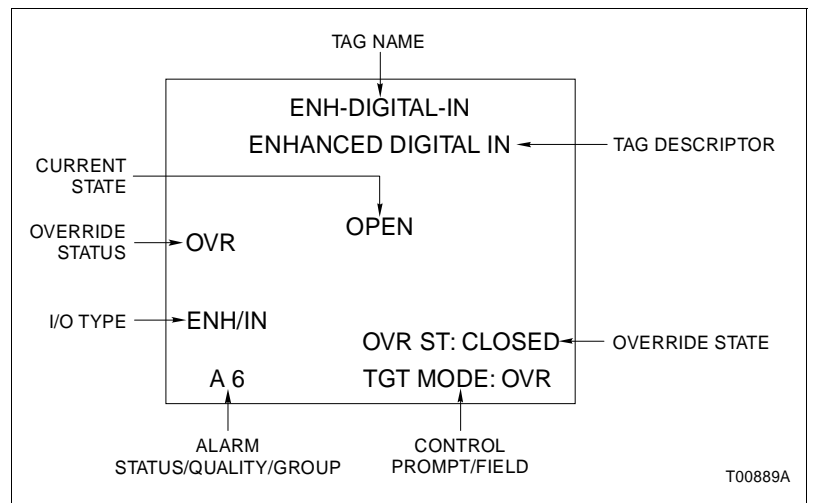

Figure 10-7. Digital Control Element

DIGITAL ELEMENT ATTRIBUTES

A digital function block exception reports the current state, alarm status, and quality presented in these elements. The following information explains the attributes that relate to a digital type of tag and can be incorporated into any graphic or custom faceplate. Figures 10-5 and 10-6 show the location of the attributes described. below

Alarm Comment	<p>The alarm comment is text that describes an alarm condition. The comment can be up to 64 characters. The comment can describe, for example, the purpose of the alarm indication or operator actions required to correct the alarm. An alarm comment can be defined for each tag alarm condition.</p> <p>An alarm for a digital type of tag is used to identify one of two possible states. The specific state that causes an alarm indication is determined by the function block configuration. A digital alarm may not actually be a problem condition, but instead an indication of a digital state transition.</p>						
Current State	<p>The current state is text that describes the output state being exception reported by a digital function block. This state is dynamic and changes as the logic state being monitored changes. The descriptor that appears is either the <i>ONE</i> or <i>ZERO</i> state descriptor defined in the database.</p>						
I/O Type	<p>Indicates the type of digital input or output:</p> <table> <tr> <td><i>ENH/IN</i></td> <td>I/O block digital input (FC 224).</td> </tr> <tr> <td><i>ENH/OUT</i></td> <td>I/O block digital output (FC 225).</td> </tr> <tr> <td><i>STD</i></td> <td>Standard digital (FC 45).</td> </tr> </table>	<i>ENH/IN</i>	I/O block digital input (FC 224).	<i>ENH/OUT</i>	I/O block digital output (FC 225).	<i>STD</i>	Standard digital (FC 45).
<i>ENH/IN</i>	I/O block digital input (FC 224).						
<i>ENH/OUT</i>	I/O block digital output (FC 225).						
<i>STD</i>	Standard digital (FC 45).						
Override Status	<p>The override status (OVR) indicates if the output state is being overridden. When the tag is in normal operation the field is blank.</p>						
Override State	<p>The input or output state of the tag is overridden with this state when the override status is enabled.</p>						

DIGITAL CONTROL

The digital control options allow changing the override status and the override state of the digital control element.

Changing the Override Status

The override status for the DIGITAL block can be changed from the console. Press **MAN/AUTO** to toggle between the normal status mode and the override status mode.

The *TGT MODE:* field indicates the targeted change.

Changing the Override State

To change the override state being stored in nonvolatile memory of a PCU module:

1. Press **SET** to display a target prompt with the current override state.
2. Press one of the following keys to select the override state.



One state output.



Zero state output.

Data Acquisition Analog Element

A data acquisition analog function code (FC 177) is used to report an analog value. It provides multilevel, rate of change, and deviation alarming capabilities for an analog point. It also supports several time based alarming options with time based alarm filtering capabilities. The console gives access to the function block to allow viewing the process variable being monitored by the block and its status. Also, it allows interacting with the block to change the input source and to enter a user-inserted value if desired. The block stores the user-inserted value in nonvolatile memory.

DANG ELEMENT ATTRIBUTES

The data acquisition analog (DANG) element represents a data acquisition analog function block in a PCU module. A DANG tag is required to monitor and control the operation of this function block.

Figure 10-8 details the information presented in a data acquisition analog element. The figure describes the elements of the **DNGFULL1.DT** symbol file. Refer to Table 4-1 for a list of symbol files that can be used for a data acquisition analog.

The data acquisition analog block exception reports the current analog value, input source mode, alarm status, and quality that display in a data acquisition analog element. The following information explains the attributes that relate to a DANG tag and can be incorporated into any graphic or custom faceplate. Figure 10-8 shows the location of the attributes described.

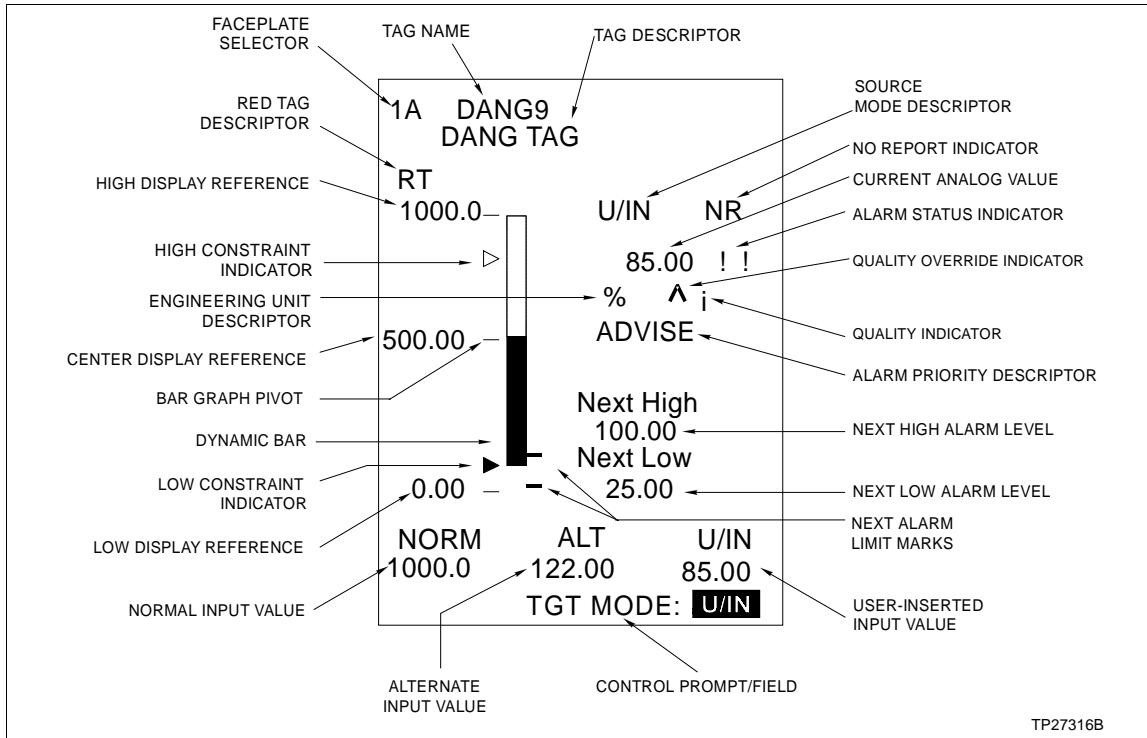

Figure 10-8. Data Acquisition Analog Element

Alarm Priority Descriptor The alarm priority descriptor is text that describes the priority of an alarm level or bad quality being reported by the function block. A priority level can be selected for each tag alarm condition. Refer to **Alarm Priority Indicators and Descriptors** in Section 12 for an explanation of the descriptors.

Alarm Status Indicator The alarm status indicator shows all normal alarm status indications. The field shows the same information that can be seen in the status position of an alarm status/quality/group field. Refer to **ALARM STATUS DESCRIPTORS** in Section 12 for a description of the alarm indicators.

The block also supports automatic alarm suppression and re-alarms. Refer to the **Function Code Application Manual** to determine the affects of these features on the reported alarm status (Table 1-2 lists instruction numbers). Refer to **RE-ALARMING** in Section 12 for information on the affects of re-alarms on the console.

Alternate Input Value The alternate input value is a dynamic value preconfigured as a contingency. The alternate can be developed from one or more other real values received from the process. It also can be the result of a calculation. A value only appears when the block is in the alternate input source mode.

Bar Graph Pivot The bar graph pivot marks the center reference point on the bar graph.

Center Display Reference	The center display reference is the center reference point between the high and low reference points for the bar graph. This shows the value that is the pivot point for the bar graph.
Current Analog Value	<p>The current analog value is the value being exception reported by the data acquisition analog function block. This is the function block output. The output value depends on the input source selection and can be an actual process value, the alternate input value, or the user-inserted value.</p> <p>During data acquisition analog function block configuration, constraint limits can be established for the normal, user-inserted, and alternate values. The maximum and minimum value displayed and reported by the block will always be within the constraint limits even if the variable being monitored exceeds the constrained level. The value is always the true value when within the constrained limits.</p>
Dynamic Bar	The dynamic bar shows the value as an expanding or contracting bar. It is a bidirectional bar that expands from the center pivot point on the bar graph in either a negative or positive direction as the process variable increases or decreases in value. For example, the center point is a value of 500.00 in Figure 10-8. If the reported value is 450.00, the bar will expand downward from the center point to show the 450.00 value proportionally between the low and center reference points.
Engineering Unit Descriptor	The engineering unit descriptor (EUD) shows the unit of measurement for the analog value. The data acquisition analog function block reports an EUD index number to select the appropriate engineering unit descriptor.
High and Low Constraint Indicators	The high and low constraint indicators mark where the constraint limits fall within the high and low reference range on the bar graph. The indicators do not appear unless constraint limits have been enabled in the function block. The triangular indicator fills when the variable is at or above a constrained limit.
High Display Reference	The high display reference is the highest value for the bar graph and constraint limits. The dynamic bar representation of the value and the constraint limit indicators are displayed proportionally between the high display reference value and the low display reference value.
Low Display Reference	The low display reference is the lowest value for the bar graph and constraint limits. The dynamic bar representation of the value and the constraint limit indicators are displayed proportionally between the high display reference value and the low display reference value.

Next Alarm Limit Marks The next alarm limit marks identify the next high and next low points on the bar graph. These correspond to the values seen in the next high alarm level field and next low alarm level field.

Next High Alarm Level The next high alarm level identifies the value that is the next high alarm level threshold for the point. Refer to Table 10-3 to determine the criteria for this field.

Table 10-3. DANG Element Next High and Next Low Alarm Limit Criteria

Current Alarm State	Next High Value ¹	Next Low Value ¹
blank (no alarm) N	H H	L L
3H 2H H L 2L 3L	> 3H 2H L 2L 3L	3H 2H H 2L 3L >
V3H V2H VH VL V2L V3L	> V3H V2H VL V2L V3L	V3H V2H VH V2L V3L >
HD LD HR LR !!	blank blank blank blank blank	blank blank blank blank blank

NOTE:

1. Value that will appear in the next alarm level fields. For example, if the current value is 45.00, the next high alarm field might be 50.00 (3H) and the next low 40.00 (2H). This indicates that the current value is between the 3H and 2H alarm values. If the current value drops below the 2H value, the 2H and H alarm values will appear.

Next Low Alarm Level The next low alarm level identifies the value that is the next low alarm level threshold for the point. Refer to Table 10-3 to determine the criteria for this field.

No Report Indicator The no report indicator shows whether the function block is in a report or a no report condition. The field appears as NR for a no report condition or blank for a report condition. Refer to **OPERATING PARAMETERS** in Section 13 for the procedures to enable or disable reporting.

Normal Input Value The normal input value is the real input value. Usually, this is the real value being received from the transmitter monitoring the process. The attribute is dynamic and changes as the variable being monitored changes. A value does not appear if the block is in alternate or user-inserted mode.

Quality Indicator The quality indicator presents all normal quality indications. The field shows the same information that can be seen in the

quality position of an alarm status/quality/group field. Refer to **QUALITY INDICATORS** in Section 12 for a description of the quality indicators.

Quality Override Indicator

The quality override indicator appears to identify that the block is in an override condition. The block allows an external source to override the quality status of the reported value. A caret (^) symbol identifies an override condition.

Source Mode Descriptor

The source mode descriptor is text that describes the input source currently selected. The PCU module reports the current mode of the block. The descriptor also identifies whether the block is locked or not locked in a certain mode. The descriptors are:

<u>Source Locked</u>	<u>Source Unlocked</u>
<i>NORM (L)</i>	<i>NORM</i>
<i>U/IN (L)</i>	<i>U/IN</i>
<i>ALT (L)</i>	<i>ALT</i>

User-Inserted Value

The user-inserted value is a numeric value established by the operator or some other supervisory device. A PCU module stores this value in nonvolatile memory. The user-inserted value can be, for example, stored lab data or an interim value if a process value is not available.

DANG CONTROL

DANG control allows changing the input source selection for a data acquisition analog function block and entering a user-inserted value. Refer to **OPERATING PARAMETERS** in Section 13 for the procedures to change the alarm reporting and exception reporting status of a DANG block.

NOTE: When the DANG block is in a no report condition, any mode change causes the block to output a single exception report.

Enabling DANG Control

To **enable** a DANG element to control a data acquisition analog function block, either enter its faceplate selector from the keyboard or activate its touch point. A *TGT MODE*: prompt appears when the element is first selected.

A block details or operating parameters display can be called by pressing **DETAILS** or **OP PARAMS** while the DANG element is active. Refer to **BLOCK DETAILS** in Section 11 for an explanation of the functions performed by using the block details display. Refer to **OPERATING PARAMETERS** in Section 13 for an explanation of the operating parameters display and its functions.

To **disable** control of the currently selected element, press **ESC** or select another element.

Selecting the Source Mode

The input source for the DANG block can only be changed from the console if the block is not in a locked state. An *(L)* appearing next to the source mode descriptor identifies a locked condition.

Press **MAN/AUTO** to toggle between the normal input source mode and the user-inserted source mode.

Press **CMPTR** to select alternate input source mode. Press **MAN/AUTO** to return to normal input source mode from alternate input source mode.

The *TGT MODE:* field indicates the targeted change and the source mode descriptor will reflect the change.

Changing the User-Inserted Value

To change the user-inserted value being stored in nonvolatile memory of a PCU module:

1. If the current user-inserted input value is not displayed in the U/IN field press **SET**. The engineering unit descriptor identifies the unit of measurement associated with the value.
2. The value can be changed using one of two methods. Key in the desired target value and press **ENTER** or press the ramp keys to increment or decrement the value. Press **ESC** to exit without making any changes.



Performs a slow, ramping value change. This changes the value 0.2 percent per keystroke.



Performs a fast, ramping value change. This changes the value 4.0 percent per keystroke.

Data Acquisition Digital Element

A data acquisition digital function code (FC 211) is used to report a digital state. It provides enhanced alarming capabilities for a digital point. The console gives access to the function block to allow viewing the device state being monitored by the block and its status. Also, it allows interacting with the block to change the input source and to enter a user-inserted value if desired. The block stores the user-inserted value in nonvolatile memory.

DADIG ELEMENT ATTRIBUTES

The data acquisition digital (DADIG) element represents a data acquisition digital function block in a PCU module. A DADIG tag is required to monitor and control the operation of this function block.

Figure 10-9 details the information presented in a data acquisition digital element. The figure describes the elements of the **DADIG1.DT** symbol file. Refer to Table 4-1 for a list of symbol files that can be used for a data acquisition digital.

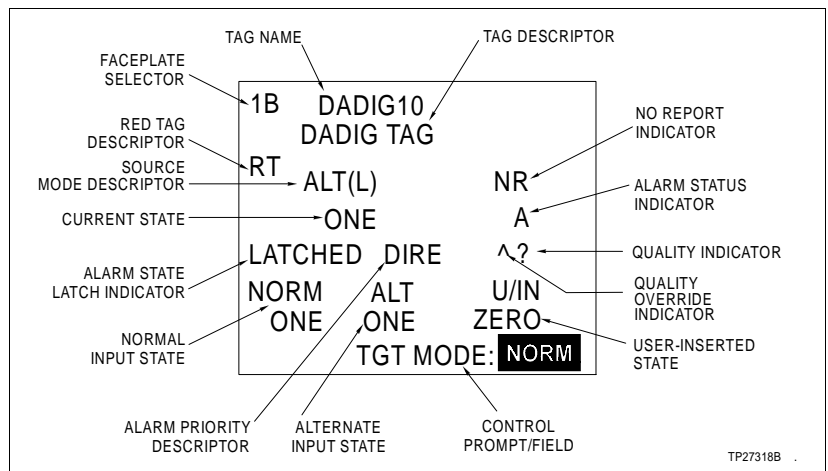

Figure 10-9. Data Acquisition Digital Element

The data acquisition digital block exception reports the current state, input source mode, alarm status, and quality that displays in a data acquisition digital element. The following information explains the attributes that relate to a DADIG tag and can be incorporated into any graphic or custom faceplate. Figure 10-7 shows the location of the attributes described.

Alarm Priority Descriptor

The alarm priority descriptor is text that describes the priority of an alarm level or bad quality being reported by the function block. A priority level can be selected for each tag alarm condition. Refer to **Alarm Priority Indicators and Descriptors** in Section 12 for an explanation of the descriptors.

Alarm State Latch Indicator

The alarm state latch indicator appears to indicate that the function block has its alarm state latch feature enabled. The field appears as *LATCHED* when enabled or blank when not. Refer to **OPERATING PARAMETERS** in Section 13 for the procedures to reset the alarm state latch if enabled.

Alarm Status Indicator

The alarm status indicator shows all normal alarm status indications. The field shows the same information that can be seen in the status position of an alarm status/quality/group field. Refer to **ALARM STATUS DESCRIPTORS** in Section 12 for a description of the alarm indications.

During data acquisition digital function block configuration, either an unconditioned input or a conditioned input can be chosen to drive alarming. Also, one of four modes of alarming can be chosen. Refer to the **Function Code Application Manual** to determine the affects of these features on the reported alarm status (Table 1-2 lists instruction numbers).

The block also supports automatic alarm suppression and re-alarming. Refer to **RE-ALARMING** in Section 12 for information on the affects of re-alarming on the console.

Alternate Input State	The alternate input state is a dynamic state preconfigured as a contingency. The alternate can be developed from another function block. A descriptor only appears when the block is in the alternate input source mode. The descriptor that appears is either the <i>ONE</i> or <i>ZERO</i> state descriptor defined in the database.
Current State	The current state is text that describes the output being reported by the data acquisition digital function block. The descriptor that appears depends on the input source selection and can be an actual process state, the alternate input state, or the user-inserted state. The descriptor that appears is either the <i>ONE</i> or <i>ZERO</i> state descriptor defined in the database. During data acquisition digital function block configuration, input conditioning can be chosen to develop the function block output. Refer to the Function Code Application Manual to determine the affects of this conditioning on the reported output (Table 1-2 lists instruction numbers).
No Report Indicator	The no report indicator shows whether the function block is in a report or a no report condition. The field appears as <i>NR</i> for a no report condition or blank for a report condition. Refer to OPERATING PARAMETERS in Section 13 for the procedures to enable or disable reporting.
Normal Input State	The normal input state is the real input to the block. Usually, this is the state being received from the process. The attribute is dynamic and changes as the device state being monitored changes. A descriptor does not appear if the block is in alternate or user-inserted mode. The descriptor that appears is either the <i>ONE</i> or <i>ZERO</i> state descriptor defined in the database.
Quality Indicator	The quality indicator presents all normal quality indications. The field shows the same information that can be seen in the quality position of an alarm status/quality/group field. Refer to QUALITY INDICATORS in Section 12 for a description of the quality indicators.
Quality Override Indicator	The quality override indicator identifies whether the block is in an override condition or not. The block allows an external

source to override the quality status of the reported value. A caret (^) symbol identifies an override condition.

Source Mode Descriptor

The source mode descriptor is text that describes the input source currently selected. The PCU module reports the mode of the block. The descriptor also identifies whether the block is locked or not locked in a certain mode. The descriptors are:

<u>Source Locked</u>	<u>Source Unlocked</u>
<i>NORM (L)</i>	<i>NORM</i>
<i>U/IN (L)</i>	<i>U/IN</i>
<i>ALT (L)</i>	<i>ALT</i>

User-Inserted State

The user-inserted state is the user-inserted digital state selected by the operator or some other supervisory device. A PCU module stores this value in nonvolatile memory. The user-inserted value can be, for example, an interim value if a process device is not available. The descriptor that appears is one of the state descriptors defined in the database for the tag.

DADIG CONTROL

DADIG control allows changing the input source selection for a data acquisition digital function block and entering a user-inserted value. Refer to **OPERATING PARAMETERS** in Section 13 for the procedures to change the alarm reporting and exception reporting status and to reset the alarm state latch for a DADIG block.

NOTE: When the DADIG block is in a no report condition, any mode change causes the block to output a single exception report.

Enabling DADIG Control

To **enable** a DADIG element to control a data acquisition digital function block, either enter its faceplate selector from the keyboard or activate its touch point. A *TGT MODE:* prompt appears when the element is first selected.

A block details or operating parameters display can be called by pressing **DETAILS** or **OP PARAMS** while the DADIG element is active. Refer to **BLOCK DETAILS** in Section 11 for an explanation of the functions performed by using the block details display. Refer to **OPERATING PARAMETERS** in Section 13 for an explanation of the operating parameters display and its functions.

To **disable** control of the currently selected element, press **ESC** or select another element.

Selecting the Source Mode

The input source for the DADIG block can only be changed from the console if the block is not in a locked condition. An *(L)* appearing next to the source mode descriptor identifies a locked condition.

Press **MAN/AUTO** to toggle between the normal input source mode and the user-inserted source mode.

Press **CMPTR** to select alternate input source mode. Press **MAN/AUTO** to return to normal input source mode from alternate input source mode.

The *TGT MODE:* field indicates the targeted change and the source mode descriptor will reflect the change.

Changing the User-Inserted State

To change the user-inserted state being stored in nonvolatile memory of a PCU module, press the following keys:

 One state output.

 Zero state output.

Text String Element

The text string element allows interacting with an application program running in a PCU module. A user-defined data export function code (FC 194) in a PCU module provides the interface between the console and the program. A data export function block can also be driven by another function block rather than directly by an application program.

The text string functionality provides a means to prompt or question an operator and have the operator respond to the prompt or question in some manner. The response may be to make some type of selection, to acknowledge an event, or to provide an answer to a question. It can also be used to simply monitor and verify the progress of a process routine through descriptive text.

The capabilities provided by the text string function are not limited to the uses previously described. A C language program or batch program executing in the PCU module determines the text string operations that can be performed.

TEXTSTR ELEMENT ATTRIBUTES

The text string (TEXTSTR) element gives access to a user-defined data export function block in a PCU module. A TEXTSTR tag is required to interact with this function block.

Figure 10-10 details the information presented in a text string element. The figure describes the elements of the **TEXTSTR1.DT** symbol file.

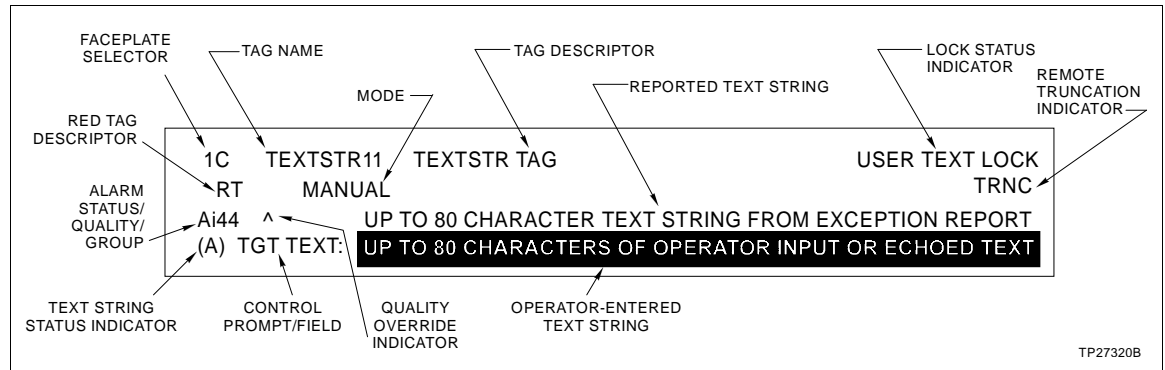

Figure 10-10. Text String Element

The user-defined data export block exception reports the text string message, alarm status, and quality that displays in a text string element. The following information explains the attributes that relate to a TEXTSTR tag and can be incorporated into any graphic or custom faceplate. Figure 10-10 shows the location of the attributes described.

Lock Status Indicator

The lock status indicator appears when the function block is in a locked condition. When locked, the block does not accept an input from the console. The default descriptor is *USER TEXT LOCK*.

Mode

The mode shows the current block operating condition. The block operates in either automatic (*AUTO*) or manual (*MANUAL*) mode. The operating mode determines how the block output is derived.

Operator-Entered Text String

The operator-entered text string only appears after the element has been selected for control. Depending on configuration, a TEXTSTR tag may or may not allow control. The text that initially appears after selecting the element for control is the same as the reported text string.

Quality Override Indicator

The quality override indicator appears when the block is in an override condition. The block allows an external source to override its quality status. A caret (^) symbol identifies an override condition.

Reported Text String The reported text string is the text string being exception reported by the user-defined data export function block (FC 194).

The standard text string element (**TEXTSTR1.DT**) accepts a text string of up to 80 characters, which is the maximum length for a text string. In a user-created text string element, the maximum length that will be accepted for a text string can be defined. An option to enable or disable local truncation for a text string is also provided. If enabled and the length of the reported text string is longer than the length allowed for in the user-created element, local truncation is indicated with an ellipsis (. . .) at the end of the text string.

Text String Status Indicator The text string status indicator has two functions. The first is to indicate that there is an alarm associated with the text string being entered if this association is considered necessary. For this purpose, the indication is either () for no alarm or (A) for alarm.

The second function is to indicate that following an operator-entered response to a prompt or question the initial prompt or question was received again by the console. This occurs when the application program has rejected the response for some reason and has sent the same text string to the console for another response. If this happens, it is possible for a prompt to appear again with the same text string without first seeing the entered reply confirmed with a new text string. A NAK (negative acknowledgment) indication is given to identify that the text string is the same prompt or question that had been previously responded to, but was regenerated. This requires, however, that the program be specifically written to prompt again after rejecting an input.

The block also supports re-alarms. Refer to the **Function Code Application Manual** to determine the affects of this feature on the reported alarm status (Table 1-2 lists instruction numbers). Refer to **RE-ALARMING** in Section 12 for information on the affects of re-alarms on the console.

Truncation Indicator The truncation indicator appears when the reported text string has been remotely truncated. Remote truncation is performed by a PCU module or the communications interface unit of the console. *TRNC* appears if remote truncation has occurred.

To identify where remote truncation is occurring and to help identify a truncation error, the operating parameters page for a TEXTSTR tag provides text string length information. A *Console String Length* field displays the length defined in the tag database for the TEXTSTR tag. A *Module String Length* field identifies the length set in the function block. A *Received String Length* field shows the actual length of the text string received in the last exception report for the tag. Refer to **TEXTSTR CON-**

TROL in this section for the procedures to call the operating parameters page.

TEXTSTR CONTROL

TEXTSTR control allows the operator to respond to a prompt or question introduced by a user-written application program. Control also allows changing the operating mode of the user-defined data export function block to establish the output of the block. Refer to **OPERATING PARAMETERS** in Section 13 for the procedures to change the alarm reporting status for a user-defined data export function block (TEXTSTR tag).

Enabling TEXTSTR Control

To **enable** a TEXTSTR element for control, either enter its face-plate selector from the keyboard or activate its touch point. A *TGT MODE:* prompt appears when the element is first selected.

The element can only be enabled for control if the *Control Enabled* field for the tag was set to *YES* during its configuration. If an attempt is made to enable a TEXTSTR element for control when the tag referenced in the element has its *Control Enabled* field set to *NO*, the following message appears:

Control is not enabled

A block details or operating parameters display can be called by pressing **DETAILS** or **OP PARAMS** while the TEXTSTR element is active. Refer to **BLOCK DETAILS** in Section 11 for an explanation of the functions performed by using the block details display. Refer to **OPERATING PARAMETERS** in Section 13 for an explanation of the operating parameters display and its functions.

To **disable** control of the currently selected element, press **ESC** or select another element.

Changing the Mode

The mode can be changed to determine the output of the user-defined data export function block. Press **MAN/AUTO** to toggle the block between manual and automatic mode. The block operates in several ways depending on its input source (application program or function block) and mode (automatic or manual).

Application Driven

When an application program drives the user-defined data export block, it always controls the block output while in automatic (*AUTO*) mode. It also always sets the alarm status and quality for the block.

When the block is placed in *AUTO* mode, the application can read any input from the console. Depending on how the program is written, it may or may not update the block output based on this input. The block does not exception report a new text string to update the display unless the application itself updates the block output or changes either the alarm status or quality status of the block. The application does not echo the text string back to the console unless the program is explicitly written to do so. An echo feature like this, which can be used to confirm that the block received the entered text, must be built into the program to occur. The block does, however, generate a new exception report automatically even if the application does not change an output when the maximum time for exception reporting expires.

When the block is in *MANUAL* mode, the application can still read any input from the console. In this case, the output may either be a new text string generated by the application, or the output may be an echo of the operator-entered text string. When the block receives an input from the console, it immediately places the input into its output buffer. This text string is output in the next exception report unless the application overwrites it before the block generates a new exception report.

Block Driven

The user-defined data export block in *AUTO* mode operates basically the same when driven by another function block as it does when driven by an application program. The difference is that the function block driving the user-defined data export block sets the alarm status and quality rather than the application program.

When the block is in *MANUAL* mode, only the console controls the block output. The block exception reports any text strings entered from the console. The text string is echoed back as the reported text string.

Table 10-5 summarizes the user-defined data export function block operation based on the input source, mode, and lock status.

Table 10-4. *TEXTSTR* Element Operating Conditions

Input Source	Mode	Lock Status	Operation
Application	AUTO	Locked	The application controls the user-defined data export block output not allowing any input from the console.
	AUTO	Unlocked	The application controls the user-defined data export block output allowing input from the console. The application may or may not update the block output based on the input from the console. It depends on how the program is written.
	MANUAL	Unlocked	Both the application and console control the user-defined data export block output. A text string received from the console can be read by the application. The text string received from the console becomes the block output unless the program updates the output with a new text string.

Table 10-4. TEXTSTR Element Operating Conditions (continued)

Input Source	Mode	Lock Status	Operation
Function block	AUTO	Locked	Another function block controls the user-defined data export block output not allowing any input from the console.
	MANUAL	Unlocked	The console controls the user-defined data export block output. A text string received from the console becomes the block output.

Inputting a Text String

The user-defined data export function block only accepts input from the console if the block is not in a locked condition. A *USER TEXT LOCK* indication identifies a locked condition. If any control is attempted while the block is locked, the following message appears:

Control Invalid While in String Interlock

To enter a text string in response to a prompt or question:

1. If the text string input is not enabled, press **SET**. The control prompt changes to *TGT TEXT:* and the reported text string will be echoed in the input field.
2. Key in a response. The maximum number of characters that can be entered is 80; however, the *Text Length* field defined in the database for the TEXTSTR tag the element references determines the maximum number of characters displayed and accepted by the element.
3. If desired, set the alarm state. Refer to **Setting the Alarm State** in this section for the procedures.
4. Press **ENTER** to send the text string.

When the module sends an exception report to the console containing a text string, the exception report also contains a sequence number associated with the text. The module uses the sequence number to insure that the response received from the console corresponds to the text that was sent. The user-defined data export block increments the sequence number each time the application program updates the block output with a new text string.

The message that is sent to the module in response to a prompt or question also contains the sequence number of the message to which the operator is responding. If the module detects a mismatch between its current sequence number and the received sequence number, it ignores the response. This insures the integrity between the prompt and the answer.

For example, a response to a question is currently being typed in and the display is updated with a new question before the response being typed is finished. This causes a mismatch between the current question, which is the newly generated one, and the response when it is finished being typed and **ENTER** is pressed. To identify the mismatch, the following message appears:

Response Is Invalid For Current Prompt

Setting the Alarm State

The ability to indicate that there is an alarm associated with a response is provided. This is indicated as either alarm (A) or no alarm (). The default is no alarm. Refer to **TEXTSTR ELEMENT ATTRIBUTES** in this section for an explanation of alarm state indications.

To indicate the alarm state for a text string, press:

Alarm.

No alarm.

SECTION 11 - TUNING AND BLOCK DETAILS

INTRODUCTION

The console gives access to INFI 90 OPEN process control unit (PCU) modules to monitor automatic control and to initiate manual control of a process. Process tuning allows adjusting function block specifications to fine tune PCU control. This section explains and provides procedures for process tuning using various console displays.

TUNING FUNCTIONS

A PCU module directs process control by executing a series of defined algorithms (function codes). After being loaded into a block address in module memory, a function code is referred to as a function block. Each function block has certain specifications that determine which other function blocks provide input to and receive output from the block. Other specifications set up the block for operation.

PCU modules have different operating modes. Normal operating modes include execute and configure. A control module must be in **execute** mode to implement its control configuration and to provide automatic process control. A module must be in **configure** mode to initially enter or to change certain control configuration specifications.

Some function block specifications can only be changed while in configure mode. Others can be changed while in either mode. Tuning is the procedure used to change specifications while a module is in execute mode. Specifications that can be changed while the PCU module is executing are referred to as **tunable**.

NOTE: Tuning operations can be limited to specific personnel by defining password security or by using key lock security. The security level of a user must give tuning access rights before any tuning can be initiated. If using key lock security, the key must be in the TUNE position.

Tuning can be performed from a tuning display and block details display, and with the *Tune* option of PCU configuration. This section explains the tuning and block details displays. Refer to **Module Configuration Option** in Section 22 for a description of the *Tune* option.

BLOCK DETAILS

A block details display can be called to view the specifications of a function block. This display can be called to view any

function block in a PCU module. Figure 11-1 is an example of the block details display.

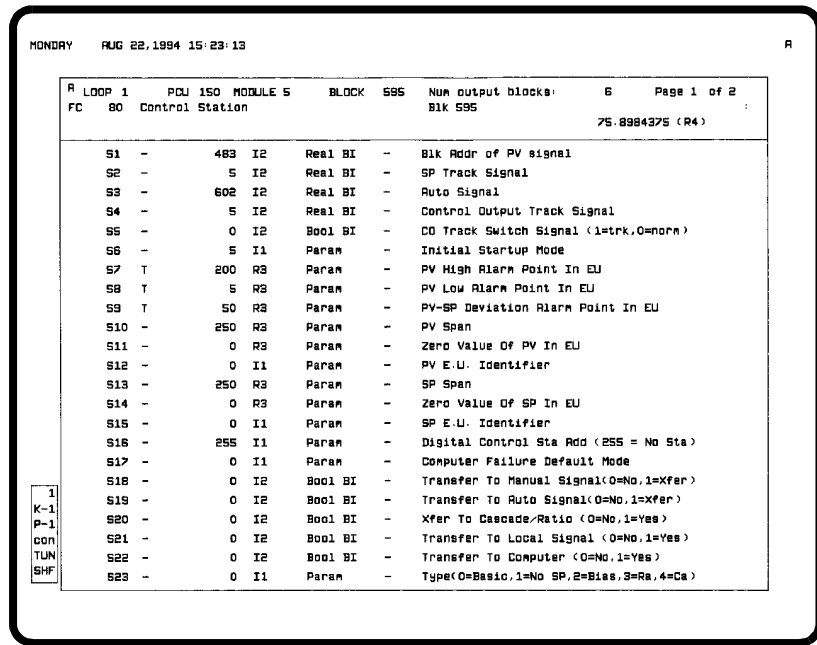

TPS0025C

Figure 11-1. Block Details Display

Calling the Block Details Display

A block details display can be called by pressing **DETAILS** or by selecting the *E Block Details* option from the operating parameters page. If using the *Block Details* option, the display details the function block referenced by the tag currently called in the operating parameters page.

DETAILS can be used in different ways. It can be used to call a block details display by tag name or index number; by loop, PCU, module, and block number; or directly by first selecting a tag element on a display.

TAG OR BLOCK ADDRESS

To call a details display by tag name or index number or by block address:

1. Press **DETAILS**. The following fields appear:

Tag Name or Index ___ LOOP ___ PCU ___ MODULE ___ BLOCK ___

2. Select a function block using one of the following methods.

- Tag** Enter a tag name or index number in the *Tag Name or Index* field. This method calls a details display for a block defined as a tag in the database.
- Block Address** Enter a function block address in the *LOOP, PCU, MODULE,* and *BLOCK* fields. This method can be used to call a details display for a block that is not defined as a tag.
3. Press **ENTER**.

TAG ELEMENT

The block details display can be called for any tag on a display:

1. Select a tag element by using the keyboard or a touch point.
2. Press **DETAILS**. The block details display will appear without any further input.

Block Details Operations

A block details display can be called for several purposes:

- To view the specifications of a function block.
- To change tunable specifications.
- To view the output or outputs of a function block.
- To identify the loop, PCU, module, and block address of a selected tag.

The following information describes the display attributes.

- Block Address** The block address is the *LOOP, PCU, MODULE,* and *BLOCK* number for the selected function block. The block address fields can be changed to call the details for another function block while the display is enabled. To call the details for another function block:
1. Move the input cursor to the address fields.
 2. Enter the new address.
 3. Press **ENTER**.
- Block Outputs** Each function block has one or more outputs. The total number of outputs for a block appears in the *Num output blocks:* field. If a block has more than one output, the address for the first block output is the *n* block. The *n* block address is the same address that is shown in the *BLOCK* field. Any additional outputs occupy addresses *n+1, n+2, n+3,* etc.

Under the *Num output blocks:* field, the *Blk* field shows the address of the currently selected block output. The bottom line of the header block shows the value of the currently selected output and its type. The page allows sequencing through all block outputs.

Example: In Figure 11-1, the currently selected function block has six outputs and the output selected is in block address 595. This can be seen as the *Num output blocks:* indicating 6 and the *Blk* field indicating 595. The current output of block 595 is:

75.8984375 (R4)

In this case, the output is an analog value. The (R4) identifies the output type as a real-four value. An (R2) will appear if a value is a real-two value; an (R3) will appear if a value is a real-three value. A digital output will be identified as either 0, 1, 2, or 3 with a (B) beside it for boolean type. The actual text and a truncation indicator will appear for a text string output with a (UD) beside it for user-defined data.

To sequence through all outputs of a block, press:



(In the station and remote control keyboard section.)

The *Blk* field updates to the block address of the newly selected output. Refer to **KEYBOARD LAYOUT** in Section 3 for the location of these keys.

Block Function A function code has a unique number and a unique noun name. The *FC* field shows the function code number and its noun name.

Display Selector The display must first be enabled before any operations can be performed. The display selector appears at the upper left corner of the display. Press the key indicated by the display selector to enable the display. The outline of the display highlights when selected. Press **ESC** to deselect and disable the display.

Page The *Page n of n* field shows the current page and total number of pages. Press **NEXT PAGE** or **PREV PAGE** to view additional pages. The field updates after each page change.

Specifications The specifications controlling the block appear at the lower section of the display. From left to right the columns are:

Number - the *Sn* represents the specification number. The number of specifications vary for function blocks.

Tunable - a *T* identifies a specification as being tunable. A specification must be tunable to change it from this display. To change the value of a tunable specification:

1. Move to the specification to change. The input cursor can only be moved to a tunable specification (*T*).
2. Enter a new value.
3. Press **ENTER** to write the change to the module.

Value - the current value set for the specification. This is either a block address or a constant value.

Type - a *B1* indicates a one-byte boolean value (logic one or logic zero). An *I1* or *I2* indicates a one or two-byte integer value (whole number). An *R2*, *R3*, or *R4* indicates a two-, three-, or four-byte real value (floating point decimal value).

Function - the function type indicates whether the actual specification value is derived from a function block output or is a constant value entered during block configuration. An address in the value column identifies the block output that provides the value. The function types are:

Bool BI - digital block input.

Int BI - integer value block input.

Param - constant entered during function block configuration.

Real BI - analog value block input.

Str BI - text string block input.

Description - A text description gives a brief explanation of the purpose of the specification.

TUNING DISPLAY

A tuning display allows adjusting a control loop while viewing the affects of these adjustments on the process variable (PV), set point (SP), and control output (CO). The display can be used to adjust the tunable specifications of the function block providing loop control.

Figure 11-2 is an example tuning display. At the top of the display is a trend element with trend lines for the process variable, set point, and control output. A station control element appears at the lower right corner of the display and a block details element to the left of the control element.

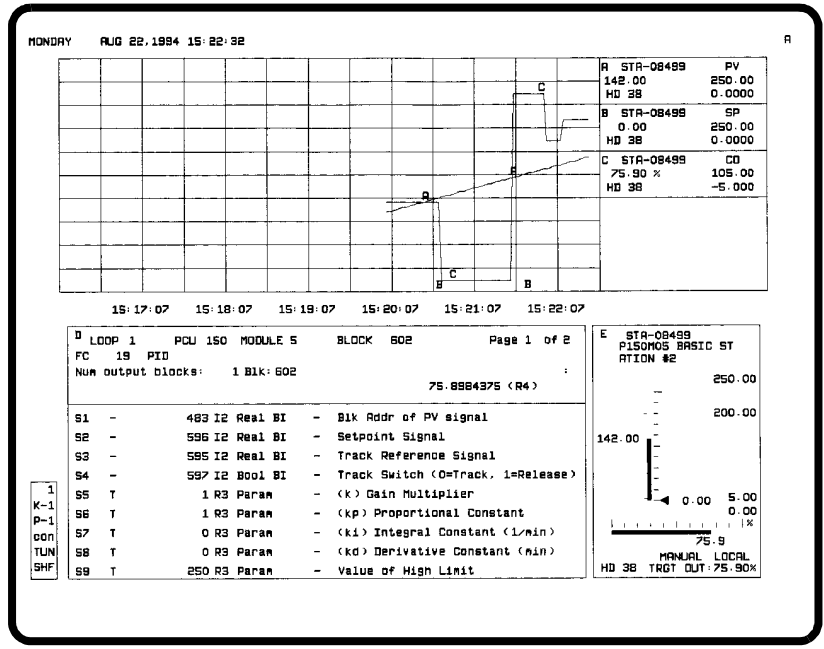

TPS0026C

Figure 11-2. Tuning Display

Calling the Tuning Display

A tuning display can be called by pressing **TUNE** or selecting the *F Tune* option from the operating parameters display. The *Tune* option is only available on the operating parameters page for a STATION tag. If using the *Tune* option, the display is called for the tag that is currently called in the operating parameters page.

TUNE can be used in different ways. It can be used to call a tuning display by tag name or index number or to directly call a tuning display by first selecting a tag element on a display.

TAG

To call a tuning display by tag name or index number:

1. Press **TUNE**. A *Tag Name or Index* field appears.
2. Enter a tag name or an index number.
3. Press **ENTER**. Either the tuning display immediately appears or the following input fields appear to indicate that additional information is required:

LOOP __ PCU __ MODULE __ BLOCK __

If the input fields appear, continue to the next step. The conditions required for immediate tuning display call-up are:

- A PID function block controls the station function block referenced by the STATION tag.
 - The STATION tag has a tuning block identified in its configuration (*Tuning Block* field in the database). In this case, the tuning block address is used to enable the immediate call-up.
4. Enter the address of a function block.
 - a. Initially, the input fields contain the address of the function block providing the PV input to the block. This address can be changed to any function block address desired. The block details for the selected block appear as part of the tuning display. Either verify and use the current address or enter a different address.
 - b. Press **ENTER**.

The display includes an element that trends the process variable, set point, and control output. It also contains a control element for the tag and a block details element. The block details element shows the specifications for the loop control function block or for the block entered in the *Loop*, *PCU*, *Module*, and *Block* field during call-up.

TAG ELEMENT

A tuning display can be called by selecting a STATION tag element on a display:

1. Select the tag element by using the keyboard or a touch point.
2. Press **TUNE**.

The same requirements for immediate tuning display call-up or the need for additional input before call-up apply. Refer to Step 2 in the previous section.

Tuning Display Operations

The tuning display enables tuning operations for a control loop. The operations that can be performed include:

- Station control.
- Tuning (block details).
- Trend control.

Block Details Element The block details element displays the controlling specifications for either:

- Loop control function block, which is normally a PID block.
- Function block designated as the tuning block for the tag.
- Selected function block.

The block details element provides the loop tuning capabilities. Refer to **Block Details Operations** in this section for an explanation of the operations that can be performed and the information available in the block details element.

Station Control Element The station control element displays the exception reported values from a station function block in a PCU module. The element can be used to monitor and initiate changes to the control loop set point, ratio index, and control output. Refer to **STATION ELEMENT** and **STATION CONTROL** in Section 9 for further explanation.

Trend Element The trend element in the tuning display provides both real-time and historical data for control loop variables. The process variable, set point, and control output of a loop appear as separate trend lines. The purpose of this element is to allow viewing historical and current values to both analyze and observe the affects of tuning for a process loop.

Initial historical data collection does not occur until the tuning display is called for the first time. Data collection continues and historical data can be accessed until the tuning display is cleared. The same operations that can be performed in any other type of trend element can be performed in this element. Refer to **TREND CONTROL** in Section 14 for more information.

The trend element collection and operation is the same as an operator assignable trend (or fast trend). PCU module data is collected every two seconds and up to two hours of historical data can be stored while the tuning display is active.

Two tuning displays can be active at one time. If two are currently active, one must be cleared before another can be called. The number of function block output trends currently active in the operator assignable trends function also affects the number of possible tuning displays. Refer to **OPERATOR ASSIGNABLE TRENDS** in Section 14 for the procedures to delete or clear an active tuning display (tuning tag) and for the procedures to delete active block output trends.

SECTION 12 - ALARM MANAGEMENT

INTRODUCTION

This section explains the console level alarm indications and processing procedures. Alarm processing begins after an alarm indication is given. Console configuration determines the indications that are given for an alarm occurrence. This section also details the information and functions available from any alarm summary and one method to manually inhibit alarm indications.

ALARM INDICATIONS

NOTE: This console does not use the device status alarm group, which is alarm group D.

Exception reports are continuously monitored to determine if an alarm condition exists. Some examples of alarm conditions that cause an alarm indication are:

- A process variable passing a certain threshold.
- A process device changing to a specific state.
- An INFI 90 OPEN node or module going off-line or operating in an error condition.
- Bad quality (if bad quality alarming is enabled).

Several different alarm features are used to notify of an alarm condition:

- Alarm status field.
- Alarm summary display.
- Alarm summary report.
- Annunciator display panel (ADP) lamp.
- Colors.
- Dynamic symbols (change based on alarm level).
- Event log.
- Flashing indicators and symbols.
- Group indicator.
- Priority indicator.
- Relay (external annunciator).
- Tone.

Some alarm indications can optionally be turned on or off and may not be implemented. Their use depends on the alarm management strategy set up for the console.

- Alarm Status Field** An alarm status field is used mainly to identify an alarm level; however, if the field is of the five-character type, it also provides quality and alarm group information. By default, an alarm status/quality/group field flashes until an alarm condition is acknowledged.
- Alarm Summary** An entry is made in the alarm summary list to identify an alarm event. The same list is used for both displayed and printed alarm summaries.
- ADP Lamp** An LED indicator lamp will light to notify when a tag enters an alarm condition. The pushbutton associated with the lamp can then be pressed to call a display. The display called should be one from which appropriate actions can be taken to correct the alarm. Refer to **ANNUNCIATOR DISPLAY PANEL** in Section 3 for additional information.
- Colors** Dynamic fields and symbols used to show alarm status normally appear in a standard color (yellow) to identify an alarm condition. Establishing some color as a standard alarm color is recommended for easier recognition. Any color can be used.
- Dynamic Symbols** Dynamic symbols can be created to change in shape, color, and position based on alarm level.
- Event Log** An entry is made in the event log to identify an alarm event.
- Group Indicator** An alarm group indicator identifies a process area or group of variables in alarm. An indicator will appear in yellow as *I* to *99*, or *S* and will flash until all alarms within the process area or group have been acknowledged.
- All alarm group indicators are presented in a fixed position at the top, right of the window. Up to 20 alarm group indicators can appear in two lines. If the area fills, an *M* appears to identify that there are more alarms. Optionally, an alarm status/quality/group field or a dedicated alarm group field can be built into a display.
- Priority Indicator** An alarm priority indicator appears to indicate that there are active alarms with a certain priority. All priority indicators are presented in a fixed position and appear in one of two ways: Numeric indicator only or pushbutton indicator. In either case, an indicator is a touch point. An indicator appears in yellow and will flash until all alarms with the priority have been acknowledged. Optionally, an alarm priority descriptor field can be built into a display.
- Relay** An alarm relay can be associated with an alarm group or an alarm priority. An alarm relay will close to trigger an external alarm annunciator when a process variable within a group or with the priority goes into an alarm condition. An alarm relay can be triggered by alarm group or by alarm priority but not both.

Tone An alarm tone can be associated with an alarm group or an alarm priority. An alarm tone will sound when a process variable within an area or with the priority goes into an alarm condition. An alarm tone can be triggered by alarm group or by alarm priority but not both.

The same indications are given if a process variable returns to its normal condition from an alarm. The only difference is that the alarm status characters turn green to indicate a normal condition when using standard colors. All or only some of these indications may be associated with a given process alarm.

An alarm quality option configuration procedure can be used to override any existing color scheme set in both standard console provided displays and user-created displays. This option sets the colors used for the alarm status field and dynamic symbols. Refer to the discussion on the alarm quality option in the **Configuration** instruction for the procedures to view the colors set for both alarm status and quality indications (Table 1-2 lists instruction numbers).

Process Alarms

The alarm status for each point within a process that is referenced by a tag is monitored by the console. The tag is required to receive exception reports generated by a process control unit (PCU) module. Each report contains information specific to a process point. A portion of the exception report is reserved for alarm status information. This information can include an alarm level for analog process variables or an alarm state for a digital process variable.

The specifications in the control configuration of a PCU module determine function block operation and also determine the alarm thresholds or the alarm state that is to trigger an alarm indication. The specifications are set during module configuration.

Depending on the function block, alarm indications for analog variables will either be a high or low indication, multilevel alarm indication, high or low deviation, or high or low rate of change alarm. A multilevel alarm ranges from a three-high to three-low level. A change to a specific state triggers a digital alarm indication. The specific state that triggers an alarm is set as one of the function block specifications.

System Alarms

A PCU module reports status information in an exception report. The status of each module in the INFI 90 OPEN system that is defined with an N90STA tag is monitored by the console. A module sends a status exception report while in any of

its on-line operating modes: Execute, configure, or error. An alarm indication is given when a message identifies a module in error. An alarm also generates whenever a module goes off-line.

Alarm Status Field

An alarm status field as an element of a display presents alarm information. The status field appears on most standard displays and can be incorporated as an element of any user-created display. This field can appear in two ways: A five-character alarm status/quality/group field (e.g., 2Hi25) or a single character field showing alarm status only (e.g., H). From left to right, the five-character status field contains:

- Two-character alarm status indicator.
- One-character quality indicator.
- Two-character alarm group number.

The alarm status indicator that appears in the first two positions depends on the type of tag. For an analog point, the characters identify the last alarm threshold that the point passed as determined and exception reported by a PCU module. The two characters also identify a change to the alarm state for a digital point and an N90STA tag alarm. For a text string report, the fields indicate whether or not there is an alarm associated with a text string response. A TEXTSTR tag reports a text string.

The quality field shows the quality of a process value or state being exception reported. The field also shows the current operating status of a tag. The operating status includes an indication that a tag has been taken off scan, it has alarm inhibiting implemented, or the value or state shown is a substituted value or state.

The last two character positions identify the alarm group to which the tag is assigned. The field appears as 1 through 99, or S (system). If it is blank, the tag is not assigned to an alarm group.

ALARM STATUS DESCRIPTORS

NOTE: The characters used to identify each alarm condition are default characters. Each descriptor can be redefined with text substitution.

The alarm status descriptors that can appear for a tag depend on its type. Table 12-1 lists the two-character alarm status descriptors. Usually, these characters appear as the first two characters of a five-character alarm status/quality/group field. They can also appear in a separate field that shows alarm

status only. Table 12-2 lists the descriptors that appear if the status field is of the single character type.

Table 12-1. Alarm Status Descriptors (Two Character)

Descriptor	Description	Tag Type
Blank	No alarm	All
3H	Three-high alarm	DAANALG, DANG
2H	Two-high alarm	DAANALG, DANG
H	High alarm	ANALOG, INTANG, DAANALG, DANG, STATION
L	Low alarm	ANALOG, INTANG, DAANALG, DANG, STATION
2L	Two-low alarm	DAANALG, DANG
3L	Three-low alarm	DAANALG, DANG
HD	High deviation alarm	DANG, STATION
LD	Low deviation alarm	DANG, STATION
HR	High rate of change alarm	DANG
LR	Low rate of change alarm	DANG
N	Return to normal from alarm	All
A	Digital	DIGITAL, INTDIG, DADIGTL, RCM, RMCB, DD, MSDD, DADIG, N90STA, TEXTSTR
*	Bad quality ¹	All
!!	Alarms suppressed	DANG, DADIG, TEXTSTR

NOTE:

1. Bad quality alarming must be enabled for the console. Refer to the discussion on alarm quality options in the **Configuration** instruction for further explanation (Table 1-2 lists instruction numbers).

Table 12-2. Alarm Status Descriptors (Single Character)

Descriptor	Description	Purpose
H	High analog alarm	Appears when a tag passes a three-high, two-high or high threshold.
L	Low analog alarm	Appears when a tag passes a three-low, two-low or low threshold.
D	Deviation analog alarm	Appears for either a high deviation or low deviation alarm.
R	Rate of change analog alarm	Appears for either a high rate of change or low rate of change alarm.
A	Alarm	Indicates a digital, N90STA, or TEXTSTR alarm.
*	Bad quality ¹	Appears when a tag is reported as in bad quality.

Table 12-2. Alarm Status Descriptors
(Single Character) (continued)

Descriptor	Description	Purpose
!	Alarm suppression	Indicates that alarm suppression is active for a tag.

NOTE:

1. Bad quality alarming must be enabled for the console. Refer to the discussion on alarm quality option in the **Configuration** instruction for further explanation (Table 1-2 lists instruction numbers).

DANG TAG

The DANG element provided uses a variable alarm type indicator field (**ed 110**) to identify a variable alarm condition. The default indicator is *V*, which appears to the left of the alarm status/quality/group field. This indicator is positioned to look like it is part of the alarm status/quality/group field.

QUALITY INDICATORS

The quality indicators that can appear for a tag show its point quality, alarm inhibit, off scan, suspect, and substituted value status. Table 12-3 lists the quality indicators. Usually, the quality indication appears as the third character of a five-character alarm status/quality/group field. It can also appear in a separate field that shows quality only.

Table 12-3. Quality Indicators

Indicator	Description
Blank	Good
*	Bad
x	Off scan
s	Substituted
?	Suspect
i	Alarm inhibited

The *i*, *x*, and *s* indicators appear after performing certain operations from the operating parameters page. These indicators identify conditions that affect console operations only, **not** module operations. The operating parameters display can be viewed at any time to see the current operating status of a tag and to perform operations that set or remove these conditions. Refer to **OPERATING PARAMETERS** in Section 13 for a description of the information presented and operations performed that relate to the *i*, *x*, and *s* indicators.

Alarm Inhibit

The alarm inhibit indication (*i*) appears when either automatic or manual alarm inhibiting is in effect. Automatic alarm inhibiting

occurs when another process variable or device defined as an alarm inhibit tag is in a specific alarm condition or changes to a specific state. Manual inhibiting is performed by using either the operating parameters or alarm group inhibit functions.

The following alarm indications do not occur when an inhibited tag goes into alarm: Alarm summary and event log entry, top line group indicator, left edge priority indicator, and alarm tone and relay activation. Also, the alarm status field does not flash for an inhibited tag but will still change to an alarm color and show alarm status (e.g., *2L*, *3H*, *A*, etc.).

Bad or Good

Each exception report received contains point quality information. A function block generating an exception report determines the quality of the value or state it is reporting. It then sets the reported quality to either bad or good. An alarm indication does not mean a point is in bad quality.

The quality of a point is good when the function block determines that its output or outputs are valid. The bad quality indicator (*) appears for a tag if the reported quality is bad.

A bad quality indication also appears if the console cannot communicate with an entire PCU or a PCU module that contains the point referenced by a tag. In this case, all points (tags) associated with the off-line PCU or PCU module show bad quality. A bad quality string appears for all dynamic fields associated with a tag in bad quality.

Off Scan

The off scan indication (x) appears when a tag is disestablished on the loop. Exception reports are not processed for any off scan tags. Any value or state fields related to the tag will contain a bad quality string.

Substituted

The substituted indication(s) appears when a tag has been forced to a certain value or state. A substitution disestablishes a tag and replaces any exception reported value or state with a substitute value or state. A substitute value or state is used in all operations in the same way as an exception reported value or state.

Suspect

The suspect indication (?) appears when a function block performs a calculation to derive the value being reported and at least one value used in the calculation was in bad quality. The

suspect indication also appears in a custom log when a calculation performed in a formula or a trend cell included at least one bad quality value.

Alarm Group Indicators

Alarm group indicators (e.g., 1 to 99, or S) help to narrow a problem down to a process area. When a tag assigned to an alarm group goes into an alarm condition, the alarm group number to which the tag is assigned appears at the title line and in a field that shows alarm group. The indicator flashes until all alarms within the process area or group have been acknowledged.

The alarm group indicators can be enabled or disabled during alarm management configuration. When enabled they appear at the title line on all displays whether they are standard or user-created displays. This allows alarm indications to be given while viewing any display. Refer to **Display Characteristics** in Section 4 for a description of fixed title line display elements and the area of the window reserved for presenting alarm group indicators.

An alarm group field can be built into a display during its creation. Usually, the alarm group is shown in the last two positions of a five-character alarm status/quality/group field. A field showing only the alarm group can be built into a display if desired.

Alarm grouping is optional and the alarm indications just described will only occur if alarm grouping is being used in alarm management. Alarm priority alarming may be in use instead. Alarm groups and alarm priorities can be used at the same time, but only one can be used to trigger alarm tones and relays.

Alarm Priority Indicators and Descriptors

Each tag type has a variable number of alarm conditions associated with it. A priority level from one to eight can be assigned to each alarm level or the alarm state of a tag and to the return-to-normal condition of a tag. The priority is assigned during configuration of a tag. Also, bad quality can be assigned a priority level. Bad quality alarming must be enabled, however, to use bad quality in alarm management.

If a tag goes into an alarm condition, a yellow alarm priority indicator appears along the left side of the window. The indicator is the number of the alarm priority level assigned to the particular tag alarm condition (e.g., 1, 2, 5). The number only identifies the existence of an alarm in the alarm summary list with that priority. It flashes until all alarms with the priority

have been acknowledged. Additionally, an alarm priority field can be used in a display to indicate an alarm priority level.

The alarm priority indicators can be enabled or disabled during alarm management configuration. When enabled, the indicators are touch points that can be used to call alarm summaries. The indicators always appear in a fixed location along the left side of the window on all displays whether they are standard or user-created displays. This allows alarm indications to be given while viewing any display. Refer to **Display Characteristics** in Section 4 for a description of the window elements and the area reserved for presenting alarm priority indicators. Refer to **CALLING AN ALARM SUMMARY** in this section for a description of how to use the touch point indicators.

An alarm priority field can be built into a display during its creation. This field presents a text descriptor to indicate priority level. Table 12-4 lists the default text descriptors for alarm priorities and the priority levels they associate with.

Table 12-4. Alarm Priority Text Descriptors

Priority	Descriptor
1	DIRE
2	CRUCIAL
3	CRITICAL
4	ALERT
5	WARNING
6	ADVISE
7	NOTIFY
8	INFORM

Using alarm priorities is optional and the alarm indications just described will only occur if alarm priorities are being used in alarm management. Alarm group alarming may be in use instead. Alarm groups and alarm priorities can be used at the same time, but only one can be used to trigger alarm tones and relays.

RE-ALARMING

The DADIG, DANG, and TEXTSTR tags support re-alarming. If enabled in the function block, an alarm indication will be reinitiated after a certain amount of time specified in the block if an alarm condition still exists since the last report. This new alarm indication triggers all normal console alarm indications and must be acknowledged.

ALARM SUPPRESSION

The DADIG, DANG, and TEXTSTR tags allow for alarm suppression. This enables turning alarms on and off globally by suppressing alarm indications at the module level. Alarm suppression is different than alarm inhibit. Alarm suppression being reported by a module affects all consoles. Alarm inhibit is a console level alarm suppression that affects only this console, but it can be configured to be broadcast to other consoles. Alarm suppression is turned on or off using the operating parameters page for a tag. Refer to **OPERATING PARAMETERS** in Section 13 for the procedures.

BAD QUALITY ALARMING

The console can be configured to treat a bad quality report as an alarm. A PCU module reports bad quality for a point in an exception report. If bad quality alarming is enabled, all normal alarm indications are given for a process variable being reported with bad quality. Additionally, an asterisk (*) appears in the alarm status position of an alarm field to identify a bad quality alarm. Bad quality indications are also given when communication cannot be established with a PCU module or node defined with an N90STA tag.

When operating on the Plant Loop communication highway, all bad quality alarms for tags appear in the alarm summary and the event log. In this case entries are made in the summary and log for all tags referencing function blocks within a PCU module or node that is off-line.

For INFI-NET systems, certain bad quality alarms are filtered out to prevent an excessive number of entries from being made in the alarm summary and event log. An entry is not made for a tag that is in bad quality due to a PCU module or a node being off-line. Only an entry for the N90STA tag defining the affected PCU module or node is made. All other alarm indications (bad quality indications) remain the same for any tags referencing function blocks within the off-line PCU module or node.

Bad quality alarming is configured by using *Alarm Quality Option*. Refer to the discussion on alarm quality option in the **Configuration** instruction for information on enabling bad quality alarming (Table 1-2 lists instruction numbers).

ALARM PROCESSING PROCEDURES

Alarm processing on the console concerns the steps required to acknowledge an alarm indication, then to initiate actions to correct the alarm condition. Alarm acknowledgment is a console level operation. An acknowledgment stops some of the indicators used to identify an alarm occurrence. After

acknowledgment, the actions taken to correct an alarm normally affect the process control responsibilities of the PCU module. For example, to maintain the control output of a process loop below a maximum limit may require initiating manual control actions from a station element.

The procedures and requirements for correcting alarms vary for each process; therefore, this section covers the alarm processing requirements at the console level only. The steps required to perform alarm processing include:

1. Silencing an alarm tone or external annunciator.
2. Acknowledging an alarm.
3. Initiating actions to correct the problem.

Silencing an Alarm Tone

An alarm tone may or may not be associated with an alarm occurrence. A tag must be part of an alarm group or have each of its alarm conditions assigned an alarm priority to trigger an alarm tone.

A tone sounds on a per tag alarm basis. When a tag that is part of an alarm group goes into an alarm condition and alarm group triggering of tones is configured, the tone assigned to that group sounds. When a tag goes into an alarm condition and alarm priority triggering of tones is configured, the tone assigned to the alarm priority of the tag alarm condition sounds. Alarm tones can be triggered by alarm group or by alarm priority but not both.

Only one tone can sound at a time. Each tone has a logical priority, pitch, volume, and duration set in its configuration. A triggered tone continues to sound until it completes its entire duration, is manually silenced, or is overridden by a higher priority tone.

When alarms in different alarm groups or alarm priorities occur simultaneously, the logical priority of the tone assigned to each group or priority is checked. This is done to determine which tone has priority and is to sound. If a tone with a higher logical priority is activated, the current tone automatically silences and the higher priority tone sounds. When the higher priority tone ceases and if lower priority tones are active, the next highest priority tone will be sounded.

A lower priority tone does not affect a higher priority tone. When a triggered lower priority tone is preempted by a higher priority tone, it remains active and its duration continues to increment. It will continue to remain active until its duration

expires and may be sounded again when the higher priority tone ceases.

Other factors within an alarm group or alarm priority also affect alarm tones. If multiple tags within a single group or priority go into alarm at the same instant, only one tone sounds to identify the entire group or priority. If there is a delay between tag alarms in a single group or priority, each alarm occurrence triggers a new alarm indication. A new alarm resets the duration counter of the current tone to zero, then the counter begins to increment until reaching its duration before the tone is turned off.

Press **SILENCE** to manually silence a tone. Acknowledging an alarm also silences an alarm tone.

Silencing an External Annunciator

The console can be set up to trigger an external alarm annunciator with one of its alarm relays when an alarm occurs. An alarm relay may or may not be associated with an alarm occurrence. A tag must be part of an alarm group or have each of its alarm conditions assigned an alarm priority to trigger an alarm relay.

A relay triggers on a per tag alarm basis. When a tag that is part of an alarm group goes into an alarm condition and alarm group triggering of relays is configured, the relay assigned to that group closes. When a tag goes into an alarm condition and alarm priority triggering of relays is configured, the relay assigned to the alarm priority of the tag alarm condition closes. Alarm relays can be triggered by alarm group or by alarm priority but not both.

Each relay has a duration set in its configuration. Normally, a relay remains closed until the alarm driving the relay returns to normal, the alarm is acknowledged, or the duration set for the relay expires. A *Relay Hold until Silenced* field on the general parameters page provides an option to change the function of the relays.

If the *Relay Hold until Silenced* field is enabled (YES), an alarm relay that closes can be manually opened by pressing **SILENCE**. If the *Relay Hold until Silenced* field is disabled (NO), a relay maintains its original functionality as described previously.

Acknowledging an Alarm

Alarm acknowledgment must be performed to stop certain alarm indications on the console. Specifically, these include a flashing alarm status field, dynamic symbol, and group or priority indicators, and an alarm tone and relay before completing their duration. Besides stopping the flashing, the

acknowledgment is also recorded in the event or operator actions log.

Alarm acknowledgment can be performed from displays that present an alarm status field, either a five-character or single character type. Examples of displays that include an alarm status field include the operating parameters, alarm summary, trend, XY plot, and operator configurable displays.

NOTE: The system status pages do not present alarm status fields but still provide the capability to acknowledge system alarms.

Most standard console displays incorporate a five-character alarm status/quality/group field. Most standard faceplate symbols provided with the console also include this five-character field. Any user-created display can be created to include an alarm status field.

Acknowledge Keys

Two choices are available for acknowledging alarms: Individually or entire page. Press **PAGE ACK** to acknowledge all alarms on a single, displayed page. To acknowledge a single alarm:

1. Press **ACK ALARM**. This calls a cross hair (+) alarm cursor that positions on the first alarm status field.
2. Press either **TAB** or **TAB BACK** to position the cursor on a specific alarm field.
3. Press **ACK ALARM** to acknowledge that alarm. The field stops flashing after being acknowledged.
4. Press **CANCEL** then **CURSOR** to clear the alarm cursor.

Correcting an Alarm Condition

As stated previously, the actions that are taken to correct an alarm condition depend on the process requirements. The ability to access the specific display on which these corrective actions can be performed is provided, however. The display is the primary display for the tag.

The primary display for a tag can be called in three different ways. The first is to select the tag element on a display, then pressing **DISPLAY**. The second method requires using a primary display selector that is part of an alarm summary. Refer to **ALARM SUMMARY** in this section for the procedures. The third method is to call the primary display for a tag by using the operating parameters page. Refer to **OPERATING PARAMETERS** in Section 13 for the procedures. A tag must be assigned a primary display during tag configuration to enable these call-up features.

ALARM SUMMARY

An alarm summary contains a list of up to 1,000 most recent acknowledged or unacknowledged alarms and the most recent acknowledged or unacknowledged return-to-normals. A summary can appear as an element of a user-created or operator configurable display and also as a complete display.

Sorting

Alarm management can be set up in a variety of ways. Part of alarm management configuration is to set up how the console processes and records alarms in its alarm summaries. The setup determines whether alarms are recorded in chronological order as alarms occur or if they are grouped by priority then chronological within the priority level. The setup applies to all summaries.

Priority sorting requires assigning a priority from one to eight to each type of alarm condition a tag may enter. Depending on the type of tag, a priority can be assigned to each analog alarm level, each digital alarm state, bad quality, and return-to-normal conditions. These are also the conditions that trigger alarm indications. The priority level is used to determine where an entry is positioned in the alarm summary list when using priority sorting. The priority of an alarm condition is also used to determine the foreground and background color of the entry. Entries appear in priority colors whether using chronological or priority sorting.

Refer to the discussion on alarm summary configuration in the **Configuration** instruction for an explanation of the *Alarm Management Type* field. This field determines the method used to sort alarms (Table 1-2 lists instruction numbers).

Return-to-Normal Alarms

Alarm management configuration determines how return-to-normal alarms are handled. One of two methods can be used: A fixed position change to a return-to-normal status or a new return-to-normal entry. Using fixed position, an alarm entry maintains its current position in a summary when the alarm returns to its normal condition. The entry changes to a return-to-normal color and the status field of the entry updates to show a return-to-normal (N) condition. An alarm entry clears and a new return-to-normal entry is added to the beginning of the list if fixed position is not used.

System Status Alarms

One of the indicators used to identify a system status alarm for a PCU module is an alarm entry in the alarm summary. A *Sys-*

tem Status I/O Error Filter option available during system configuration can be enabled to prevent alarm entries from being made for status alarms caused by a remote I/O error or local I/O error. These error are filtered out to prevent the alarm summary form being overwhelmed by these types of reports.

Alarm Summary Attributes

Summaries can be created in sizes varying from a full size to $\frac{1}{8}$ -size. Entries in a summary can be for all alarm groups or priorities or can be limited to only specific alarm groups or priorities. A maximum of 24 entries can appear in a single alarm summary display or element. The information presented in each alarm summary entry depends on the line format configured for the particular summary. The element size and the format can vary from summary to summary.

A single entry can include all or only some of the following attributes:

Alarm comment - alarm comment defined during tag configuration.

Alarm condition - alarm status, quality, and group number of the tag in alarm.

Current value - current value, state, and status of the tag in alarm.

Date of alarm - date of alarm occurrence.

Engineering unit - engineering unit of an analog value.

Exceeded limit value - violated alarm limit for an analog type of tag.

Latched alarm time - alarm time of occurrence latched to the tag in alarm. This allows displaying the time of occurrence in a return-to-normal entry in the alarm summary.

Latched alarm date - alarm date of occurrence latched to the tag in alarm. This allows displaying the date of occurrence in a return-to-normal entry in the alarm summary.

Priority - alarm priority assigned to the tag alarm condition (selected in the tag database).

Remote truncation status - truncation status to indicate the presence or absence of remote truncation. Remote truncation is performed by a PCU module or the interface unit of the console.

Tag description - tag description defined during configuration.

Tag index - tag index number.

Tag name - tag name defined during configuration.

Text string - text string of a TEXTSTR tag (with or without local truncation indication).

Time of alarm - time of alarm occurrence.

Flexibility in creating an alarm summary is provided. The overall purpose of a given alarm summary will determine the data and alarms that will appear. The type of information and how this information is presented depends on system, tag database, and alarm summary format configuration and the alarm summary display itself. Refer to the discussion on alarm management configuration in the **Configuration** instruction for the procedures to view the current settings controlling alarm summary operation (Table 1-2 lists instruction numbers).

Figure 12-1 shows a standard, full page alarm summary. The display source file for this summary display is the **ALM-SUMFL.DT** source file.

Alarm Summary Element

An alarm summary element, no matter how it is configured, contains some standard display attributes. These attributes can be identified in Figure 12-1.

Alarm Count Next to the page indicator are two fields that present alarm count information. From left to right, the first field shows the number of current alarms. This is the total number of acknowledged, unacknowledged, and return-to-normal alarms saved. This does not necessarily reflect the number of alarms in the current list unless the alarm summary shows the alarms for all alarm groups or priorities. The second field shows the number of these total alarms that have not been acknowledged. Each field increments or decrements as alarm conditions change.

Alarm Summary Selector An alphanumeric in the upper left corner of the element is its selector (not shown in Figure 12-1). A summary must be made active by using this selector before any operations can be performed. The selector characters only appear in an alarm summary of an operator configurable display or when built into a user-created summary. If the default, full page summary is called using **ALARM SUMM**, it automatically comes up in the active mode.

Page Indicator A page indicator appears as either *CURRENT* or *PAGING*. *CURRENT* appears when the summary is at its first page. *PAGING* appears while the next page or any subsequent pages are on the screen.

Primary Display Selectors

The letters along the left edge of the element are for calling the primary display associated with a tag in the list. The selectors may appear along the right edge of a user-created summary. A primary display must have been defined for a tag for its adjacent selector to function.

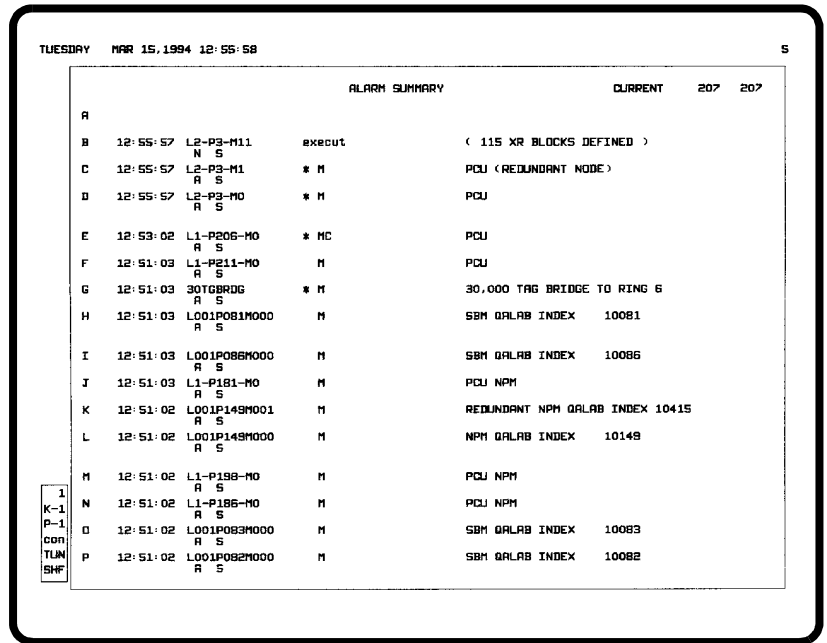

TPS0219C

Figure 12-1. Alarm Summary Display

Alarm Summary Operations

Alarm summary operations allow viewing and acknowledging alarms and calling the primary display for each tag in the list. The same operations can be performed on a tag in alarm and a tag that has returned to normal. These operations are standard for all alarm summaries.

The top four lines of the *CURRENT* (first) page are reserved for new entries. A new alarm entry initially appears in this area until being repositioned in the list.

CALLING AN ALARM SUMMARY

An alarm summary can be called in several ways:

- Pressing **ALARM SUMM**.
- Pressing a function key or ADP pushbutton.
- Display by name.
- Alarm priority indicator touch point.

ALARM SUMM

A standard full page alarm summary is assigned to **ALARM SUMM** by default. This gives single key access to a complete list of

active alarms. Keyboard configuration provides the option to assign any user-created summary to this key if desired. Press **ALARM SUMM** at any time to call an alarm summary.

Function Key or Pushbutton	The standard alarm summary or any display that contains an alarm summary can be called by pressing a function key or an ADP pushbutton to which the display is assigned.
Display by Name	The standard alarm summary or any display that contains an alarm summary can be called by using the <i>Display by Name</i> option. This includes operator configurable displays. The display name must be known in this case.
Touch Point	Alarm priority indicators are touch points that can be used to call an alarm summary. By default the summary called by a particular touch point will contain only the alarms with the priority indicated. For example, selecting the priority 4 touch point calls an alarm summary that shows only priority four alarms.

ACTIVATING A SUMMARY

If a default, full page summary is called using **ALARM SUMM** or an alarm priority indicator touch point, it automatically comes up in active mode. An alarm summary in an operator configurable or user-created display must be made active by selecting it using key select or a touch point. Alphanumeric characters normally appear at the upper left corner of the display. These characters indicate the key or key sequence that must be pressed to activate the summary for operation.

Press **ESC** to deactivate an alarm summary. Press the key select characters again or use a touch point to reactivate an alarm summary. The key select characters are not available in the default, full page alarm summary called with **ALARM SUMM**. For this alarm summary, use the touch point built into the display to reactivate the alarm summary or press **ALARM SUMM** to call the display again in the active mode.

PAGING THROUGH ENTRIES

A single alarm summary element may have several pages of entries. The number of pages depends on the size of an element and the total number of active alarms. Press **NEXT PAGE** or **PREV PAGE** with the summary element selected to page through the entire list of entries. Press **HOME** to quickly move back to the first page.

ACKNOWLEDGING AN ALARM

An alarm in an alarm summary element can be acknowledged in the normal way. An alarm status field as part of each alarm entry allows this acknowledgment. Two choices are available

for acknowledging alarms: Individually or an entire page. Press **PAGE ACK** to acknowledge all alarms on a single, displayed page. To acknowledge a single alarm:

1. Press **ACK ALARM**. This calls a cross hair (+) alarm cursor that positions on the first alarm entry.
2. Press either **TAB** or **TAB BACK** to position the cursor on a specific entry.
3. Press **ACK ALARM** to acknowledge the alarm. The field stops flashing after being acknowledged.
4. Press **CANCEL** then **CURSOR** to clear the alarm cursor.

PROCESSING A RETURN-TO-NORMAL

When a tag returns to a normal condition, a return-to-normal indication is given in the alarm summary. Also, an indication is given in the alarm status/quality/group field (N) for the tag. An entry in a summary flashes to identify a change from alarm to normal. It clears from the summary as soon as it is acknowledged.

CALLING A PRIMARY DISPLAY

A primary display can be called for any alarming tag in the summary list by pressing a single key. For this function to work, however, a tag must have a primary display assigned to it. Press the key indicated by the letter adjacent to an alarm entry to call a primary display.

ALARM GROUP INHIBIT

The alarm group inhibit page provides several capabilities. Use this function to:

- Inhibit tag alarming for an entire process area or group.
- View the number of tags in each alarm group.
- Determine the total number of tags in alarm.
- Determine the total number of tags in alarm that have not been acknowledged.
- Determine the number of tags in alarm within each alarm group.
- Determine the number of tags in alarm that have not been acknowledged for each alarm group.

The alarm group inhibit page can be used to manually inhibit certain alarm indications for an entire area or group of process variables. The following alarm indications do not occur when an inhibited tag goes into alarm: alarm summary and event log entry, top line group indicator, left edge priority indicator, and alarm tone and relay activation. Also, the alarm status field does not flash for an inhibited tag but will still change to an alarm color and show alarm status (e.g., 2L, 3H, A, etc.).

Alarm indications for individual process variables (tags) can be manually inhibited by using the operating parameters page. Refer to **OPERATING PARAMETERS** in Section 13 for the procedures. The tag database provides an automatic alarm inhibit feature.

Each alarm group from 1 to 99, or S can be inhibited individually or a range of groups can be inhibited. Use the *Alarm Group Inhibit* option to inhibit or enable an alarm group. The option can only be used to enable alarming for a group that was inhibited by using this function. Automatic inhibiting and operating parameters page inhibiting are not affected. Figure 12-2 shows the page used. To choose the option, first press **GENL FCTNS MENU**, then select the following menu items in the sequence shown.

- C OIS Operations
- D Alarm Group Inhibit

MONDAY JAN 10, 1994 09:23:27 ALARM GROUP INHIBIT 1 10 11 15 18 22 23 27 28 33 34 38 39 50 5											
Group	Inhibit	Tags	In Alarm	Unacked	Group	Inhibit	Tags	In Alarm	Unacked		
1	NO	22	1	1	16	NO	30	0	0		
2	NO	7	0	0	17	NO	207	0	0		
3	NO	7	0	0	18	NO	117	3	3		
4	NO	7	0	0	19	NO	10	0	0		
5	YES	4	0	0	20	NO	35	0	0		
6	NO	29	0	0	21	NO	35	0	0		
7	YES	22	0	0	22	NO	35	15	15		
8	NO	0	0	0	23	NO	35	10	10		
9	NO	41	0	0	24	NO	349	0	0		
10	NO	17	1	1	25	NO	349	0	0		
11	NO	22	12	12	26	NO	349	0	0		
12	YES	73	0	0	27	NO	373	37	37		
13	NO	0	0	0	28	NO	349	38	38		
14	NO	0	0	0	29	NO	68	0	0		
15	NO	35	4	4	30	NO	165	0	0		
Total Tags in Alarm				393	Total Unacknowledged Alarms				393		
1 K-1 P-1 con tun SHF	A Inhibit Individual Group B Inhibit Range of Groups C Starting Group to Display										

TPS0081B

Figure 12-2. Alarm Group Inhibit Page

The fields of the page provide both alarm information and the capability to change inhibit status. The fields and their purpose include:

Group - alarm group number; 30 alarm groups appear on a single page.

Inhibit - current alarm inhibit status of the group. A *YES* in this field identifies the group as being inhibited, a *NO* appears for uninhibited.

Tags - total number of tags in the group.

In Alarm - total number of tags currently in an alarm condition. This includes both acknowledged and unacknowledged alarms.

Unacked - total number of tags in alarm that have not been acknowledged.

Total Tags in Alarm - total number of tag alarms for all alarm groups that are not inhibited.

Total Unacknowledged Alarms - total number of tag alarms that have not been acknowledged for all alarm groups that are not inhibited.

The alarm group inhibit page is capable of displaying the information for up to 30 alarm groups at a time. Press **NEXT PAGE** or **PREV PAGE** to page through all alarm groups.

Options at the bottom of the page:

- Enable an input cursor and position the cursor on a specific group to inhibit or enable.
- Select a single or range of tag groups to inhibit or enable.
- Select a starting group number that becomes the first entry in the displayed list of 30 groups.

Selecting the First Group

To change the first entry displayed on the page to another alarm group:

1. Press **C** to select the *Starting Group to Display* option. An *Enter Group Number* field appears.
2. Enter an alarm group number from 1 to 99, or S.
3. Press **ENTER**. The selected group then becomes the first in the list of 30 entries.

Inhibiting Individual Groups

To change the inhibit status for individual groups:

1. Press **[A]** to select the *Inhibit Individual Group* option. An *Enter Group Number* field appears.
2. Enter an alarm group number from 1 to 99, or S.
3. Press **[ENTER]**. This positions an input field in the *Inhibit* column of the indicated group. After the input field is on the page, it can be repositioned to any group by using the cursor control keys.
4. Enter **YES** to inhibit the group. Enter **NO** to uninhibit the group. Continue to enable or disable all desired groups.
5. Press **[ENTER]** after all status changes have been made. The message *Group Inhibit change queued* appears after entering.

Inhibiting a Range of Groups

To change the inhibit status for a range of groups:

1. Press **[B]** to select the *Inhibit Range of Groups* option. The following fields appear:

Starting Alarm Group ___ *Ending Alarm Group* ___ *Inhibit* ___

2. Enter a starting group number from 1 to 99, or S in the *Starting Alarm Group* field.
3. Enter an ending group number from 1 to 99, or S in the *Ending Alarm Group* field. The ending group must be equal to or greater than the starting group.

NOTE: Enter a range of 1 to S to specify the entire alarm group range. Group S is the last group.

4. Enter **YES** in the *Inhibit* field to inhibit the range. Enter **NO** to uninhibit the range.
5. Press **[ENTER]**. The following message appears after entering:

Group Inhibit change queued

SECTION 13 - TAG OPERATIONS

INTRODUCTION

This section describes the functions that give operating parameters, status, and configuration information for tags in the console database. The process conditions being reported for a tag can be viewed with the operating parameters and tag summaries pages. Additionally, tag summaries can be printed. This section also explains how to print a tag database listing.

OPERATING PARAMETERS

The operating parameters function can be accessed to view the current operating information for a tag and also to view database information. The information presented is for the process point or PCU module or node the tag references. For a process point, the page shows the inputs and outputs of the function block the tag references. The display also gives event logging, reporting, alarming, and alarm inhibit status information for a tag.

The operating parameters page options are used to:

- Disestablish or reestablish tag communication.
- Manually inhibit or uninhibit tag alarming.
- Call a primary display.
- Substitute values.
- View block details.
- Call a tuning display for a STATION tag.
- Call a module problem report for an N90STA tag.
- Suppress or unsuppress function block alarming for a DANG, DADIG, or TEXTSTR tag.
- Turn function block exception reporting on or off for a DANG or DADIG tag.
- Force an exception report from a DANG or DADIG tag when function block exception reporting has been turned off.
- Reset the alarm state latch for a DADIG tag.

Figure 13-1 shows an example operating parameters page.

MONDAY JAN 10, 1994 09:23:05 OPERATING PARAMETERS				1 10 11 15 16 18 22 23 27 28 33 34 38 39 50 5			
1166	FIC-457	REACTOR A	NAT GAS FLOW	PV	65	LB/HR	
Type	STATION						
PV Full Scale	100	Setpoint	65	Loop	2		
SP Full Scale	100			PCU	9		
High Alarm	90	Control Output	55	Module	30		
Low Alarm	20			Block	50		
PV Zero Scale	0	Ratio Index	0				
SP Zero Scale	0					Alarm Messages Printed	YES
Deviation Limit	999					Alarm Messages Saved	YES
						Operator Actions Printed	YES
Alarm Group	18					Operator Actions Saved	YES
						Scan Off	NO
						Alarming Inhibited Manually	NO
						Alarming Inhibited by Group	NO
						Alarming Inhibited by Tag	NO
1 K-1 P-1 con tun SHF		A Scan Off	C Primary Display	E Block Details			
		B Alarm Inhibit	D Substitute Value	F Tuning			

TPS0029B

Figure 13-1. Operating Parameters Page

Calling the Operating Parameters Page

An operating parameters page can be called in two ways: Either by menu selection or by a key. To call the operating parameters page:

1. Press **GENL FCTNS MENU**, then select the following menu items in the sequence shown.

C OIS Operations
 ↳ A Operating Parameters

- or -

Press **OP PARAMS**.

In either case, a *Tag name or Index* field appears.

2. Key in a valid tag name or index number.
3. Press **ENTER**.

OP PARAMS can also call the operating parameters page for a tag directly without requiring any input. To do this:

1. Select a tag element by key select or a touch point.
2. Press **OP PARAMS**.

After calling the display, press **NEXT PAGE** or **PREV PAGE** to sequence to the operating parameters page for the next or previous tag in the database.

Common Tag Information

The information that appears in the operating parameters page varies depending on tag selection. The following information is common to all tag types.

Alarm Comment Under the tag descriptors, the display presents an alarm comment field. The text displayed in this field depends on the current tag alarm condition. The field remains blank if the tag is not in alarm. Each alarm condition for a tag can have a different alarm comment. The comment changes as the tag enters a different alarm condition.

Alarm Group An alphanumeric in the *Alarm Group* field identifies the alarm group to which the tag is assigned. The field will indicate *0* if the tag is not assigned to an alarm group, or it will indicate *1* through *99*, or *S*. A tag is assigned to an alarm group during tag configuration.

Alarm Inhibit Status If any *Alarm Inhibited* fields indicate *YES*, alarm indications do not occur for the tag. Alarm indications are given if all fields indicate *NO*.

The *Alarming Inhibited Manually* field gives the status of manual inhibiting. Manual inhibiting is performed by using the operating parameters *Alarm Inhibit/Enable* option.

The *Alarming Inhibited by Group* field gives the status of alarm group inhibiting. Alarms for an entire alarm group can be inhibited. Alarm group inhibiting is performed by using the *Alarm Group Inhibit* option. Refer to **ALARM GROUP INHIBIT** in Section 12 for a description.

The *Alarming Inhibited by Tag* field gives the status of automatic inhibiting. The automatic alarm inhibit feature is enabled in the database. Using this feature, alarm inhibiting is based on the alarm condition or state of another tag. A *NO* in this field indicates that automatic inhibiting is not currently in effect. A tag index number appears if automatic inhibiting is in effect. The index number is of the tag defined in the database to automatically inhibit this tag (i.e., *Alarm Inhibit Tag* field). The inhibit tag in a certain alarm condition or state will cause the alarm indications for this tag to be inhibited.

Alarm Status To the far right of the display on the same line as the alarm comment field is an alarm status/quality/group field. This field presents all normal alarm and quality indications. The field also provides normal alarm processing capabilities, specifically alarm acknowledgment. The same conditions that

appear on all other displays that use a five-character alarm status/quality/group field appear in this display.

The quality indications that relate directly to this function are *i* for alarm inhibited, *x* for off scan, and *s* for substituted. The alarm status indication that relates directly to this function is *!!* for suppressed alarming.

Communications Status	The <i>Scan Off</i> field identifies a tag as being either established or disestablished with the loop. Disestablished means that the tag is completely disconnected from communications with the loop. When <i>YES</i> , exception reports for the tag are not being received and processed. A <i>NO</i> indicates normal communications with the loop. Scan can be turned on or off with the <i>Scan On/Off</i> option.
Function Block Address	The <i>Loop</i> , <i>PCU</i> , <i>Module</i> , and <i>Block</i> fields are the address of the function block within a PCU module that this tag references.
Tag Description	At the top line of the display starting at the left, the index number, tag name, and tag description appear. These are the descriptors defined in the database for the tag.
Tag Events	<p>The operating parameters page shows event logging information for a tag. Event logging records alarm events and operator actions events. It can be set up to print events immediately as they occur and to save events for periodic printing. Fields on this page show the event logging setup as defined in the database.</p> <p>NOTE: Tag configuration determines the operation of event and operator actions logging for a single tag. Event log configuration determines the operation of event and operator actions logging for all tags.</p> <p>If the <i>Alarm Messages Printed</i> field is <i>YES</i>, alarm events for this tag appear in an immediately printing event or operator actions log. Alarm events do not appear if <i>NO</i>.</p> <p>If the <i>Alarm Messages Saved</i> field is <i>YES</i>, alarm events are being saved for this tag as they occur for periodic log printing. Alarm events are not being saved if <i>NO</i>.</p> <p>If the <i>Operator Actions Printed</i> field is <i>YES</i>, operator actions events for this tag appear in an immediately printing events or operator actions log. Operator actions events do not appear if <i>NO</i>.</p> <p>If the <i>Operator Actions Saved</i> field is <i>YES</i>, operator actions events are being saved for this tag as they occur for periodic log printing. Operator action events are not being saved if <i>NO</i>.</p>
Tag Type	The <i>Type</i> field shows the tag type. Information related to the tag appears directly under the <i>Type</i> field and is dependent on

the type of tag selected. Generally, the information includes the scale and alarm limit levels and additionally it includes values that can be user-substituted.

For example, the set point, control output, and ratio index values appear and can be substituted for a STATION tag. The status information for a node or PCU module appears for an N90STA tag.

Value or State

At the far right of the top line is a field that shows either an analog value or a digital state. In most cases, this field is the current output of the function block referenced by the tag. If the value presented is an analog exception reported value, an engineering unit descriptor (EUD) appears to the right of the value.

NOTE: An N90STA tag does not use this field.

Tag Specific Information

The information that appears in the operating parameters page varies depending on the tag selected. The following information is specific to a tag type.

NOTE: The operating parameters page does not provide any additional tag specific information for a TEXT tag.

**ANALOG and INTANG
Tag**

The following additional information appears in the operating parameters page for an ANALOG or INTANG tag:

- Full scale limit.
- High alarm limit.
- Low alarm limit.
- Zero scale limit.
- I/O type (I/O block ANALOG tag).
- Override enable status (I/O block ANALOG tag).

This information is exception reported by the analog function block.

DAANALG Tag

The following additional information appears in the operating parameters page for a DAANALG tag:

- Alarm deadband value.
- Full scale limit.
- High alarm limit.
- Low alarm limit.
- Three-high alarm limit.
- Three-low alarm limit.
- Two-high alarm limit.
- Two-low alarm limit.
- Zero scale limit.

The scale limit information is exception reported by the analog function block. The alarm limits and the alarm deadband value come from the database.

DADIG Tag The following additional information appears in the operating parameters page for a DADIG tag:

- Alarm control mode.
- Alternate value.
- One state descriptor.
- Real value.
- User inserted value.
- Zero state descriptor.

The state descriptors come from the database. The alarm control mode and values are exception reported by the digital function block.

DADIGTL, DIGITAL, and INTDIG Tag The following additional information appears in the operating parameters page for a DADIGTL, DIGITAL, or INTDIG tag:

- Alarm state descriptor.
- One state descriptor.
- Zero state descriptor.
- I/O type (I/O block DIGITAL tag).
- Override enable status (I/O block DIGITAL tag).

The one and zero state descriptors come from the database. The alarm state descriptor is derived from an exception report from the digital function block. The block identifies which of its states is the alarm state. For example, if the alarm state indicated in the function block is the one state then the alarm state descriptor will be the same as the one state descriptor.

DANG Tag The following additional information appears in the operating parameters page for a DANG tag:

- Alarm control status.
- Alternate value.
- Center reference value.
- Deviation value.
- High alarm deadband.
- High alarm limit.
- High constraint value.
- High rate of change limit.
- High reference value.
- Low alarm deadband.
- Low alarm limit.
- Low constraint value.
- Low rate of change limit.
- Low reference value.
- Real value.
- Three-high alarm limit.
- Three-low alarm limit.

- Two-high alarm limit.
- Two-low alarm limit.
- User inserted value.

This information is exception reported by the analog function block.

DD AND RCM Tag The following additional information appears in the operating parameters page for a DD and RCM tag:

- One state descriptor.
- Zero state descriptor.

This information comes from the database.

DEVSTAT Tag The following additional information appears in the operating parameters page for a DEVSTAT tag:

- Device number.
- Device subtype.
- Device type.

This information comes from the database.

MSDD Tag The following additional information appears in the operating parameters page for an MSDD tag:

- One state descriptor.
- Requested state descriptor.
- Three state descriptor.
- Two state descriptor.
- Zero state descriptor.

The three, two, one, and zero state descriptors come from the database. The requested state descriptor identifies which output state was last selected. For example, if a two state output was last selected then the requested state descriptor will be the same as the two state descriptor.

N90STA Tag The following additional information appears in the operating parameters page for an N90STA tag:

- Configuration error.
- Module error.
- Module mode.
- Status bytes.

The status bytes, module mode, and module error status are exception reported by the node, module, or console the tag references. The configuration error is derived from a comparison of the tag configured in the database and the node or module type received in an exception report. If they do not match, the field indicates an error.

RMCB Tag The following additional information appears in the operating parameters page for an RMCB tag:

- Error message.
- Feedback one descriptor.
- Feedback two descriptor.
- One state descriptor.
- Permissive one descriptor.
- Permissive two descriptor.
- Zero state descriptor.

The one and zero state descriptors come from the database. The descriptors that appear as the permissive one, permissive two, feedback one, and feedback two descriptors are derived from the actual conditions being exception reported by the function block. Two descriptors (one for the zero state and another for the one state) are defined in the database for each of these conditions. For example, if the block reports a one state for the permissive two input to the block then the descriptor defined for the two state in the database appears.

Up to ten different error messages can appear for the tag. The run state, interlock status, and feedback status reported by the function block determines the message that is displayed.

RMSC Tag The following additional information appears in the operating parameters page for an RMSC tag:

- High limit.
- Low limit.

This information is exception reported by the remote manual set constant function block.

STATION Tag The following additional information appears in the operating parameters page for a STATION tag:

- Control output value.
- Deviation alarm limit.
- High alarm limit.
- Low alarm limit.
- Process variable full scale limit.
- Process variable zero scale limit.
- Ratio index value.
- Set point full scale limit.
- Set point value.
- Set point zero scale limit.

This information is exception reported by the station function block.

TEXTSTR Tag The following additional information appears in the operating parameters page for a TEXTSTR tag:

- Console string length.
- Module string length.
- Received string length.

The console string length comes from the database. The module string length is exception reported by the text string function block. The received string length is the actual length of the text string received by the console. These fields can be referenced to determine where any truncation occurred.

Display Operations

Several operations can be performed from the operating parameters page to control a tag. The operations vary depending on the type of tag for which the operating parameters page is called.

SCAN OFF/ON

Option *A* appears as either *Scan Off* or *Scan On* depending on the current condition of the tag. Press **A** to toggle between on and off. This is a console level operation.

A scan off condition can be identified by:

- *Scan Off* field indicating *YES*.
- An *x* in a quality field.
- Value or state fields displaying a bad quality string.

ALARM INHIBIT/ENABLE

Option *B* appears as either *Alarm Inhibit* or *Alarm Enable* depending on the current manual alarm inhibit condition of the tag. Press **B** to toggle between inhibit and enable. This is a console level operation.

A manual alarm inhibit condition can be identified by:

- *Alarming Inhibited Manually* field indicating *YES*.
- An *i* in a quality field.

PRIMARY DISPLAY

The *Primary Display* option calls the primary display for the tag. The display is normally the one used to perform actions on the tag. Press **C** to call the primary display. The operating parameters page is exited after choosing the option.

A tag must have a primary display identified in its configuration for this option to function. If it does not, selecting the option has no affect.

SUBSTITUTE VALUE

The *Substitute Value* option disestablishes a tag and allows entering a substitute value. Substitution is a console level operation. A substituted value is not sent on the communication highway. Substitutions do not affect execution of a PCU module. A substitute value is used in all console operations in the same way as an exception reported value.

The following information can be substituted:

- A substitute value can be entered for an analog value reporting tag.
- The output state can be substituted for a digital state reporting tag: Zero, one, two, or three.
- A substitute text string of up to 80 characters and an alarm status indication can be entered for a text string reporting tag.

Substitution can be performed on all tag types except N90STA and DEVSTAT tags. For these tag types, the *Substitute Value* option is not available.

NOTE: For a DANG or DADIG tag, this is a console level or local substitution only. This is not the same as selecting the user-inserted value, which is a PCU module level substitution (global substitution).

Analog Value

To make an analog value substitution:

1. Press **[D]**. An input cursor positions on the first field available for substitution. The *Scan Off* field should update to *YES* and the quality should update to *x* after the *Substitute Value* option is selected. The quality will update to *s* after making the actual substitution.

If more than one value for the tag can be substituted, the cursor can be moved between the different fields for substitution. For a STATION tag, **[SET]**, **[OUT]**, and **[RATIO]** can also be pressed to position the input field on the *Setpoint*, *Control Output*, and *Ratio Index* fields respectively.

2. Key in a new value or press:



Performs a slow, ramping value change. This changes the value 0.2 percent per keystroke.



Performs a fast, ramping value change. This changes the value 4.0 percent per keystroke.

3. Press **ENTER**.
4. Press **ESC** to deactivate and remove the input cursor.

Digital State

To make a digital state substitution:

1. Press **D**. The following prompt appears:

Substitute by pressing desired State Key

The *Scan Off* field should update to *YES* after the *Substitute Value* option is selected. The quality will update to *s* after making the actual substitution.

2. Press:



Sets a digital type of tag to a one state substituted output. Sets an MSDD tag to a three state substituted output.



Sets an MSDD tag to a two state substituted output.



Sets a digital type of tag to a zero state substituted output. Sets an MSDD tag to a one state substituted output.

A digital state substitution occurs immediately after pressing one of the control keys.

Text String

To make a text string substitution:

1. Press **D**. The *Scan Off* field should update to *YES* and the quality should update to *x* after the *Substitute Value* option is selected. The quality position will update to *s* after making the actual substitution.
2. Key in the substitute text string.
3. Enter **YES** in the *Alarm* field to indicate that there is an alarm associated with the text. Enter **NO** to indicate no alarm.
4. Press **ENTER**.
5. Press **ESC** to deactivate and remove the input cursor.

Unsubstitute

To unsubstitute a value, press **A** to select the *Scan On* option. This removes the substitution and reestablishes loop communication for the tag.

BLOCK DETAILS

The *Block Details* option can be selected to call a block details display for the current tag. The block details display presents information on the parameters controlling the function block that the tag is referencing. The option is not available for DEVSTAT, N90STA, INTDIG, and INTANG tags. Refer to **BLOCK DETAILS** in Section 11 for an explanation of the information available and operations performed by using this display.

TUNING

The *Tuning* option is available to call a STATION tag tuning display. The tuning display allows adjusting loop control parameters, viewing the affects of these adjustments, and initiating station control. Refer to **TUNING DISPLAY** in Section 11 for an explanation.

PROBLEM REPORT

The *Problem Report* option is available for N90STA tags only. The option calls a display listing detailed problem information for a node or PCU module. The problem report is for the node or module referenced by the N90STA tag. Refer to **MODULE PROBLEM REPORTS** in Section 21 for an explanation of information presented by this display.

SUPPRESS/ALLOW ALARMS

The operating parameters page enables an option used to control alarm suppression for a DANG, DADIG, or TEXTSTR tag. Depending on the current tag status, the option appears as either *Suppress Alarms* or *Allow Alarms*. This option activates or deactivates alarm suppression at the PCU module function block level. This is different than using the *Alarm Inhibit/Enable* option, which locally controls alarm indications and affects only this console.

Press **F** to toggle between suppress and allow. If the tag is set to suppress, the module does not report any alarms including high or low level alarms, high or low deviation alarms, high or low rate of change alarms, or a change to an alarm state. The current alarm suppression status and the type of alarm control being implemented by the module function block is identified under *Alarm Control*.

A suppressed alarm condition for a tag can be identified in the alarm status/quality/group field. The status position of the field appears as *!!* to indicate suppressed alarms.

ON/OFF REPORT

The operating parameters page enables an option used to change the reporting status of a DANG or DADIG tag. Depending on the current tag status, the option appears as either *On Report* or *Off Report*. This option turns reporting on or off at the PCU module function block level. This is different than using the *Scan On/Off* option, which locally disestablishes or reestablishes communication with a point and affects only this console.

Press **G** to toggle between on and off. The function block does not generate any exception reports when reporting is off. When the tag is initially set to off, the function block sends one final exception report to update the console.

A no report condition can be identified by an *N* appearing at the top right of the operating parameters page and in the DANG or DADIG tag faceplate element.

FORCE REPORT

A *Force Report* option is provided for a DANG or DADIG tag. This option can be used to force the function block to generate an exception report while the block is in a no report condition. Press **H** to initiate a forced report.

LATCH RESET

A *Latch Reset* option is provided for a DADIG tag. This option can be used to reset the alarm state latch. This ability must be enabled in the function block, however. The alarm state latch function causes the block to remain in its current output state and alarm status when an alarm occurs. When latched, the output state and the alarm status reported by the block do not update until a reset is initiated from the console or the control logic initiates a reset.

TAG SUMMARIES

The console provides the ability to both display and print summaries of process information. The information in each entry of a summary comes from an exception report and from the database. Specifically, the information includes:

ALM/QUAL - all normal alarm status and quality indications in a five-character alarm status/quality/group field.

ENGUT - unit of measurement for an analog value.

HIGH LMT - span or maximum limit for an analog value.

LOOP-NOD-MOD-BLK - hardware loop, node (PCU), and module number and software function block number of the block in a PCU module the tag references.

LOW LMT - zero or minimum limit for an analog value.

MODE - input source selection for a DANG or DADIG tag. Refer to **Data Acquisition Analog Element** and **Data Acquisition Digital Element** in Section 10 for an explanation of the indications presented.

PRIORITY - priority level descriptor for of an alarm condition. Refer to **Alarm Priority Indicators and Descriptors** in Section 12 for an explanation of the descriptors.

OVR - override enable status indicator for I/O block ANALOG and DIGITAL tags.

STATUS - status for a DANG, DADIG, and TEXTSTR tag:

V - variable alarming enabled for a DANG tag.

^ - quality override condition for a DANG, DADIG, or TEXTSTR tag.

@ - constrained value for a DANG tag.

L - alarm state latch enabled for a DADIG tag.

N - no report condition for a DANG or DADIG tag.

TAG DESCRIPTION - description for the tag as defined in the database.

TAG INDEX - tag database index number.

TAG NAME - name of the tag as defined in the database.

TAG TYPE - type of tag.

TRNC - indicates the presence or absence of remote truncation for a text string. A PCU module or the interface unit of the console performs remote truncation. *TRNC* appears if the displayed text string has been truncated remotely.

VALUE - current value, state, or text string. For all options except *A General Tags*, these are snapshots.

The display allows for a 37-character text string. Local truncation of a text string is indicated with an ellipsis (. . .) at the end

of the text string. This occurs if the string is more than 37 characters.

Use the *Tag Summaries* option to both view and print a tag summary. Figure 13-2 shows the page used. To call this page, first press **GENL FCTNS MENU**, then select the following menu items in the sequence shown.

B OIS Utilities
 ↳ C Tag Summaries

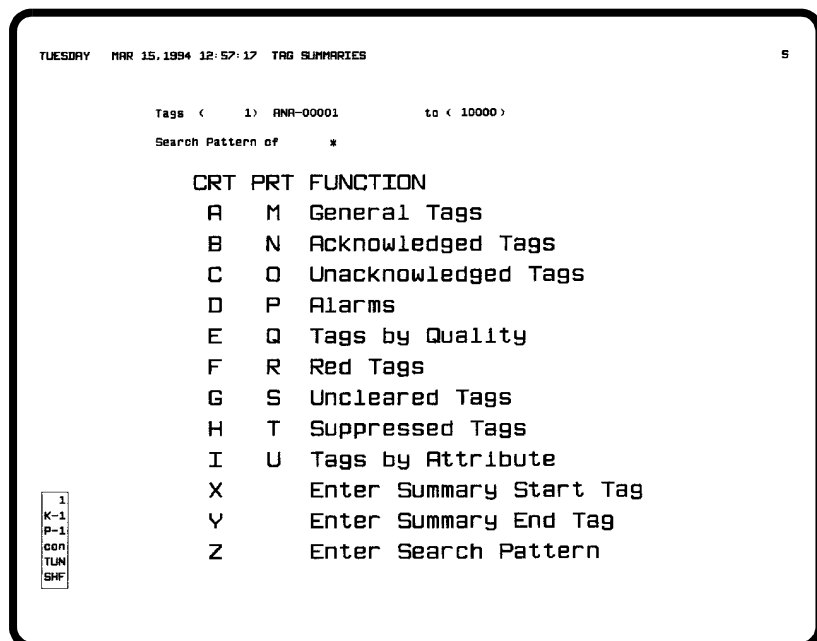

TPS0105C

Figure 13-2. Tag Summaries Menu

The tag summaries menu has choices for on-screen presentation (options A through I) or printing (options M through U) of a tag summary. It also has options for specifying a start and end tag range and a tag name search pattern. A summary is either for all tags or for only those tags in a specific condition depending on the menu option chosen.

The fields at the top of the page indicate the current tag range and search pattern. Use options X and Y to set the tag range. Use option Z to set the search pattern. Initially, the default is the entire tag range and a search pattern of *. The asterisk is a wild card character that specifies all tags.

The steps required to display or print a summary are:

1. Set the tag range.
2. Set the search pattern.

3. Select a display (*CRT*) or print (*PRT*) summary option. Refer to **Summary Options** in this section for a description of the available options and the types of summaries they produce.

Setting the Tag Range

All *CRT* or *PRT* options reference the tag range when compiling data for a summary. The tag range can be used to limit the displayed or printed tag summary to only tags within a certain tag index range. This is only necessary if the current range shown at the top of the page is not the desired range.

To specify a range:

1. Select the *X Enter Summary Start Tag* option. A *Tag Name or Index* field appears.
2. Enter either the tag name or index number of the first tag that is to appear in the summary list, then press **ENTER**.
3. Select the *Y Enter Summary End Tag* option. A *Tag Name or Index* field appears.
4. Enter either the tag name or index number of the last tag that is to appear in the summary list, then press **ENTER**. The index number of the ending tag must be equal to or greater than the starting tag.

The starting index number and its tag name and the ending index number and its tag name appear at the top of the page.

Setting the Search Pattern

All *CRT* or *PRT* options reference the search pattern when compiling data for a tag summary. The search pattern can be used to filter the displayed or printed summary. Only tags having names that match the search pattern appear in the summary.

Wild card characters can be used when entering a search pattern. The asterisk (*) represents multiple characters, the question mark (?) a single character. For example, ABC* limits the list to only those tags with tag names having ABC as their first three characters. Any combination of * and ? can be used. Multiple occurrences of ? are supported. Multiple occurrences of * are treated as ? after the first *.

To enter the search pattern:

1. Select the *Z Enter Search Pattern* option. A *Search Pattern* field appears.
2. Enter a search pattern of up to 14 characters, then press **ENTER**.

The *Search Pattern of* field at the top of the page updates to show the pattern. The default is * for an unrestricted search.

Summary Options

The tag summaries page provides several options when creating a process summary listing. The options determine which tags based on their current operating condition appear in a summary list. All options reference the range and search pattern entries when compiling the summary. The following types of summaries can be created with the different options.

- Acknowledged Tags** The summary compiled with the *Acknowledged Tags* option contains tags that are currently in an alarm or return-to-normal condition and have been acknowledged. An entry in the *ALM/QUAL* column denotes a tag in an alarm condition and no entry in this column identifies a normal condition.
- Alarms** The summary compiled with the *Alarms* option contains a list of all tags in an alarm condition whether acknowledged or unacknowledged. Return-to-normal alarms do not appear in this type of summary.
- General Tags** The *General Tags* option does not restrict the summary to any specific operating condition. Using this option, a displayed summary updates to show current process values. A printout contains snapshot values.
- Red Tags** The summary compiled with the *Red Tags* option contains a list of all tags that are currently red tagged. Red tagging is performed by using the *Red Tag Status* option. Refer to **RED TAGGING** in Section 22 for a description of the option.
- Suppressed Tags** The summary compiled with the *Suppressed Tags* option contains a list of all tags having alarm suppression enabled. Alarm suppression can be enabled or disabled for a tag by using the operating parameters function. Alarm suppression is different than alarm inhibit. Refer to **SUPPRESS/ALLOW ALARMS** in this section for an explanation.
- Tags by Attribute** The summary compiled with the *Tags by Attribute* option contains a list of all tags in a particular alarm group, having a certain tag type, or having a certain address. An option chosen from a submenu selects which attribute is to be search for when compiling the summary. The submenu appears after choosing the option. The submenu options include:
- A Tags by Alarm Group* - enter an alarm group number. A valid entry is 1 to 99, or S.
- B Tags by Type* - enter a tag type. Any valid tag type can be entered.

C Tags by Address - enter a loop, PCU, and module number.

Tags by Quality

The summary compiled with the *Tags by Quality* option contains a list of all tags in a certain quality condition. An option chosen from a submenu selects the type of quality that is to be searched for when compiling the summary. The submenu appears after choosing the option. The submenu options include:

A Inhibited Tags - lists all tags that have alarm inhibiting implemented either manually or automatically. An inhibit indication (i) appears in the quality position of the *ALM/QUAL* column to identify an inhibited tag. Manual inhibiting is performed by using the operating parameters function or *Alarm Group Inhibit* option.

B Off Scan Tags - lists all tags that are currently disestablished or off scan. A tag is set to an off scan condition by using the operating parameters function. An off scan indicator (x) appears in the quality position of the *ALM/QUAL* column to identify an off scan tag.

C Bad Quality Tags - lists all tags being exception reported with bad quality. All fields for these tags contain a bad quality string. A bad quality indicator (*) also appears in the quality position and the alarm status position of the *ALM/QUAL* column to identify a tag reporting bad quality.

D Substituted Tags - lists all tags that currently have substituted values. These tags have been taken off scan and forced to a certain value, state, or condition. Substitutions are made by using the operating parameters function. A substitute indicator (s) appears in the quality position of the *ALM/QUAL* column to identify a substituted tag.

E Suspect Tags - lists all tags being exception reported with suspect quality. A suspect indicator (?) appears in the quality position of the *ALM/QUAL* column to identify a suspect tag.

F Custom Query - invokes a dialog box which permits the selection of various quality attributes to query the tag database with.

Unacknowledged Tags

The summary compiled with the *Unacknowledged Tags* option contains tags that are currently in an alarm or return-to-normal condition but have not been acknowledged. An entry in the *ALM/QUAL* column denotes a tag in an alarm condition and no entry in this column identifies a normal condition. The *ALM/QUAL* fields flash for tags in alarm.

Uncleared Tags

The *Uncleared Tags* option does not function for this console.

Selecting an Option

Select any tag summary option from the tag summary menu (Figure 13-2) to initiate a display or print of a summary. After an option is chosen, a summary displays or processing of a print request begins depending on the option chosen.

DISPLAY

Options A through I display a summary. Up to 24 tags can appear on a single page. Press **NEXT PAGE** or **PREV PAGE** to view additional summary pages. Press **ESC** at any time to exit a summary page.

NOTE: All options except A *General Tags* are snapshots.

A displayed summary presents all normal alarm indications. Alarm acknowledgment **cannot** be performed from these summary pages. Figure 13-3 is an example tag summary page.

TAG INDEX	TAG NAME	TAG DESCRIPTION	VALUE	ENG. UT	TAG TYPE	LOOP-MOD-MOD-BLK
ALM/QUAL	MODE	PRIORITY	STATUS		LOW LMT	HIGH LMT TRNC
S17	RNR-00517	P20EM20 REV LVL	3019	EUID022	ANALOG	1 -206 -20 - 48
S18	RNR-00518	P20EM20 SYSTEM FREE TIME	63.04	%	ANALOG	1 -206 -20 - 49
S19	RNR-00519	P20EM20 CYCLE TIME OVERRUN	0.148		ANALOG	1 -206 -20 - 53
S20	RNR-00520	P20EM20 OVERRUN COUNT	0		ANALOG	1 -206 -20 - 54
S21	RNR-00521	P20EM20 CPU UTILIZATION	35.28	%	ANALOG	1 -206 -20 - 55
S22	RNR-00522	P20EM20 CURRENT CYCLE TIME	0.088		ANALOG	1 -206 -20 - 56
S23	RNR-00523	P20EM20 PREV CYCLE TIME	0.248		ANALOG	1 -206 -20 - 57
S24	RNR-00524	P20EM20 YEAR	92		ANALOG	1 -206 -20 - 63
S25	RNR-00525	P20EM20 SIGNAL GEN VRL	0	EUID000	ANALOG	1 -206 -20 - 171
S26	RNR-00526	P20EM20 SIN WAVE	0	EUID000	ANALOG	1 -206 -20 - 191
S27	RNR-00527	P20EM20 SIN WAVE	0	EUID000	ANALOG	1 -206 -20 - 193
S28	RNR-00528	P20EM20 SIN WAVE	0	EUID000	ANALOG	1 -206 -20 - 195
GENERAL TAGS						

TPS0103B

Figure 13-3. Example Tag Summary

PRINT

Options M through U initiate a printout of a tag summary. The following message appears while the requested, printed summary is being compiled:

Processing page n

If **ESC** is pressed while the message displays, the print request is terminated. After the final page has been sent to the printer, control returns to the main menu. Press **CANCEL** at any time to complete the current page, quit the creation of subsequent pages, and return to the summaries menu. Figure 13-4 is an example tag summary printout.

12:21:36 21-JAN-1993		*** GENERAL TAGS			***			PAGE 001	
TAG INDEX	TAG NAME	TAG DESCRIPTION	VALUE	TAG TYPE	LOOP-NOD-MOD-BLK	LOW LMT	HIGH LMT	TRNC	
ALM/QUAL	MODE	PRIORITY STATUS		ENG UT					
100	ANA-00100	ANALOG TAG 0100	32	A	2 - 3 - 2 -	504			
				LITRES	-1	60			
101	ANA-00101	ANALOG TAG 0101	32	A	2 - 3 - 2 -	505			
				LITRES	-1	60			
102	ANA-00102	ANALOG TAG 0102	1	A	2 - 3 -11 -	330			
	L 12	WARNING			1	12			
103	ANA-00103	ANALOG TAG 0103	34	A	2 - 8 -30 -	176			
				LITRES	-1	60			
104	ANA-00104	ANALOG TAG 0104	33	A	2 - 8 -30 -	177			
				LITRES	-1	60			
105	ANA-00105	ANALOG TAG 0105	34	A	2 - 8 -30 -	178			
				LITRES	-1	60			
106	ANA-00106	ANALOG TAG 0106	50	A	2 - 3 -11 -	31			
					0	100			
107	ANA-00107	ANALOG TAG 0107	7	A	2 - 3 -11 -	47			
	H 12	WARNING		IN/HR	3	7			
108	ANA-00108	ANALOG TAG 0108	35	A	2 - 3 -11 -	69			
		WARNING			0	100			

TPS0104B

Figure 13-4. Example Tag Summary Printout

A printout occurs at the printer assigned to the window. Look at the keyboard status block to determine which printer. A maximum of 60 tags appear on a single printed page. Each page contains the same information as the displayed version.

Each printed summary contains snapshot values or states. A time added to the page shows the time at which the summary page was compiled. The summary title and page number also appear in the first line. The time is different for each page to reflect a closer time approximation for collected, dynamic information.

Each printed page of a summary is contained in a single file that is sent to the printer. This frees the printer while the page is being formatted. A message displays to identify the current page being generated.

Perform a Custom Query

To perform a custom tag database query:

First press **GENL FCTNS MENU**, then select the following menu items in the sequence shown

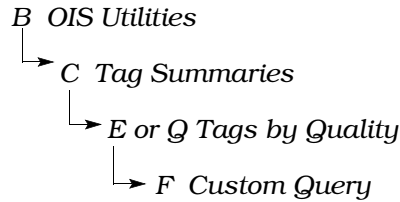

The custom query option opens a dialog box (Figure 13-5).

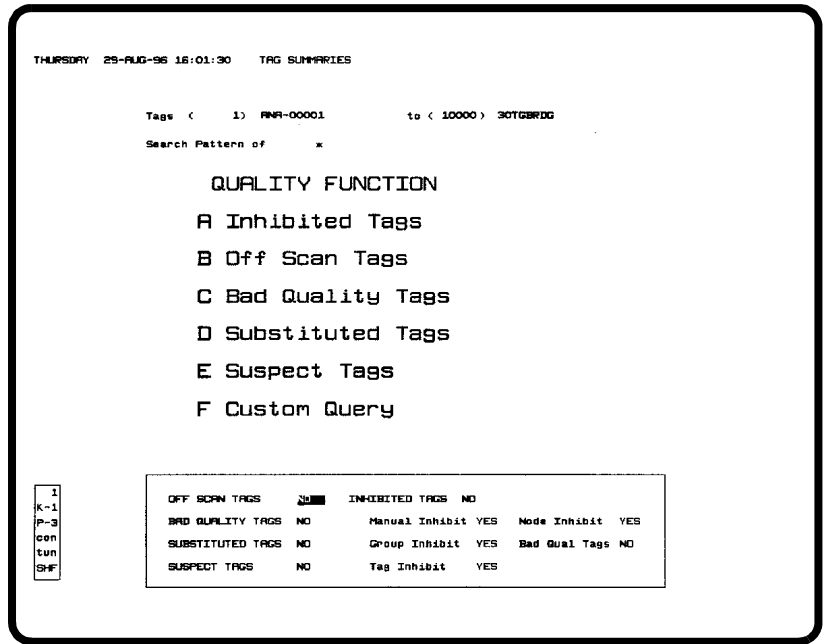

TS00004

Figure 13-5. Custom Query Window

1. Set the options as desired. Refer to Table 13-1.

NOTE: The custom query option uses a logical OR function when multiple tag qualities are selected for a summary.

2. Press **ENTER** to either print or display the summary and save the selected options to disk.

Table 13-1. Custom Query Options

Option	Function
Off scan tags	Yes = query includes tags with the indicated quality. No = tags with the indicated quality are not included in query.
Bad quality tags	
Substituted tags	
Suspect tag	

Table 13-1. Custom Query Options (continued)

Option	Function
Inhibited tags	Yes = allows selection of inhibit states to be included in the query. No = disables inhibit state selection for a custom query.
Manual inhibit Group inhibit Tag inhibit Node inhibited	Yes = includes tags that are inhibited in the query. No = inhibited tags not included in query.
Bad quality tags	Yes = tags with bad quality are included in the query. No = tags with bad quality are not included in the query.

PRINT TAG LIST

The print tag list utility can be used to print a complete or partial tag database listing. The printed tag list shows the information that is defined in the database for tags. The printout resembles the tag configuration page and contains all the same fields.

Use the *Tag List* option to initiate a tag list printout. Figure 13-6 shows the page used. To call this page, first press **GENL FCTNS MENU**, then select the following menu items in the sequence shown.

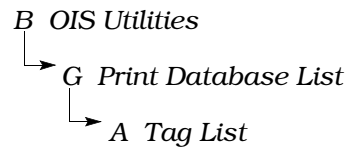

The tag list menu has three separate choices for selecting which tag indexes to print. The listing can be for all tags or for only defined or undefined tags. Also, the menu provides options for specifying a starting and ending tag range and a tag name search pattern. The tag list printout occurs at the printer assigned to the window. Look at the keyboard status block to determine which printer.

The fields at the top of the page indicate the current tag range and search pattern. Use options *D* and *E* to set the tag range. Use option *F* to set the search pattern. Initially, the default is the entire tag range and a search pattern of *. The asterisk is a wild card character that specifies all tags.

The steps required to print a tag list include:

1. Setting the tag range.

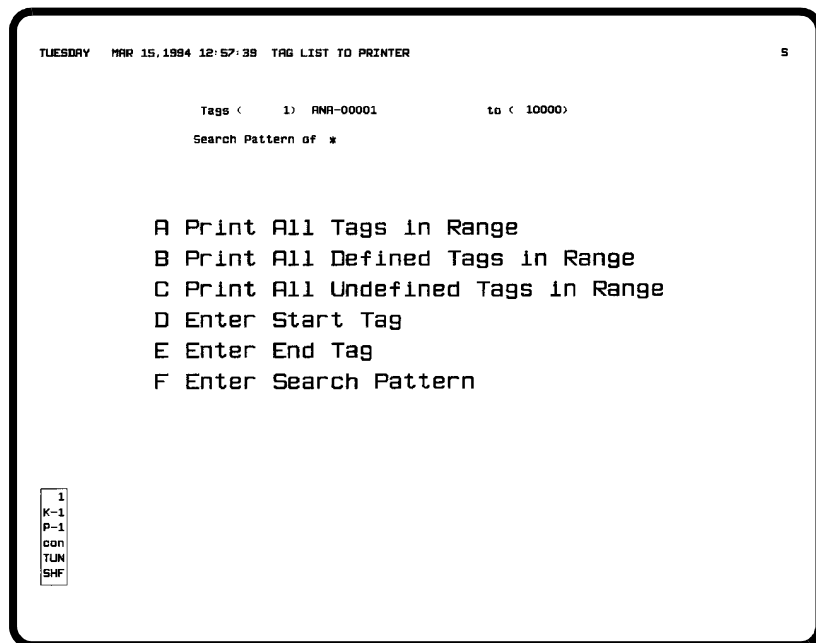

TPS0106B

Figure 13-6. Tag List to Printer Page

2. Setting the search pattern.
3. Selecting the tag types to print.

Setting the Tag Range

The tag range can be used to limit the tag list printout to only tags within a certain tag index range. This is only necessary if the current range shown at the top of the page is not the desired range. To specify a range:

1. Select the *D Enter Start Tag* option. A *Tag Name or Index* field appears.
2. Enter either the tag name or index number of the first tag that is to appear in the printout, then press **ENTER**.
3. Select the *E Enter End Tag* option. A *Tag Name or Index* field appears.
4. Enter either the tag name or index number of the last tag that is to appear in the summary list, then press **ENTER**. The index number of the ending tag must be equal to or greater than the starting tag.

The starting index number and its tag name and the ending index number and its tag name appear at the top of the page.

Setting the Search Pattern

A search pattern can be used to filter the tag list printout. Only tags with names that match the search pattern appear in the printout.

Wild card characters can be used when entering a search pattern. The asterisk (*) represents multiple characters, the question mark (?) a single character. For example, ABC* limits the list to only those tags with tag names having ABC as their first three characters. Any combination of * and ? can be used. Multiple occurrences of ? are supported. Multiple occurrences of * are treated as ? after the first *.

To enter the search pattern:

1. Select the *F Enter Search Pattern* option. A *Search Pattern* field appears.
2. Enter a search pattern of up to 14 characters, then press **ENTER**.

The entered search pattern should appear in the *Search Pattern of* field at the top of the page. The default is * for an unrestricted search.

Selecting the Tags to Print

Options *A*, *B*, and *C* determine which tags appear in the printout. The *Tag Type* field for a tag is checked when using options *B* and *C*. The range and search pattern are also referenced when compiling the listing.

Print All Tags in Range - press **A** to print all tags.

Print All Defined Tags in Range - press **B** to print all defined tags. Defined tags are any with tag types other than UNDEF.

Print All Undefined Tags in Range - press **C** to print all tags that have an UNDEF tag type. The printout provides a complete list of available tag index numbers.

After initiating a tag list print, the list is compiled then formatted for printing. The following message appears to identify the page currently being processed:

Processing page n

Exiting after making a selection and while the message is displaying causes the printout to stop.

If tags within the range matching the selected tag type cannot be found, the following message appears:

Nothing in Range to Print w/this Option

SECTION 14 - TREND OPERATIONS

INTRODUCTION

Trending provides a historical perspective of process conditions for analysis of current operations. This section explains:

- Information presented in a standard or custom trend display.
- Trend control using the keyboard.
- Operator assignable trends.
- Printing a trend definition list.

Refer to **TRENDING** in Section 2 for a discussion of the INFI 90 OPEN distributed trending system.

TREND DATA SOURCE

Trend data for a display can come from three different sources:

- INFI 90 OPEN distributed trending system (i.e., trend blocks).
- Open access system (OAS). The open access system can retrieve data collected and stored by the INFI 90 OPEN distributed trending system. It retrieves the data in the same way as the console. Access to this data is given to the console so the data can be displayed by the console. The open access system performs all data storage rather than the console.
- Operator assignable trends function. This data is not retrieved from trend blocks.

Refer to the discussion on trend definition and the open access system in the **Configuration** instruction for further explanation of data sources for trending (Table 1-2 lists instruction numbers).

TREND DISPLAY

Both standard and custom trend display capabilities are provided. The standard trend display templates come in a number of set sizes ranging from a full size to ¼-size display. The custom trend display can be set to any desirable size so long as it is not larger than the allowable maximum display size. This section explains the trending operations using either standard or custom trend displays provided with the console. The escape commands defined during creation of a trend display determine the capabilities of the display.

Figure 14-1 is an example trend display. It shows the display as it appears after being accessed then selected for control. The display shown contains a standard, 1/2-size trend element.

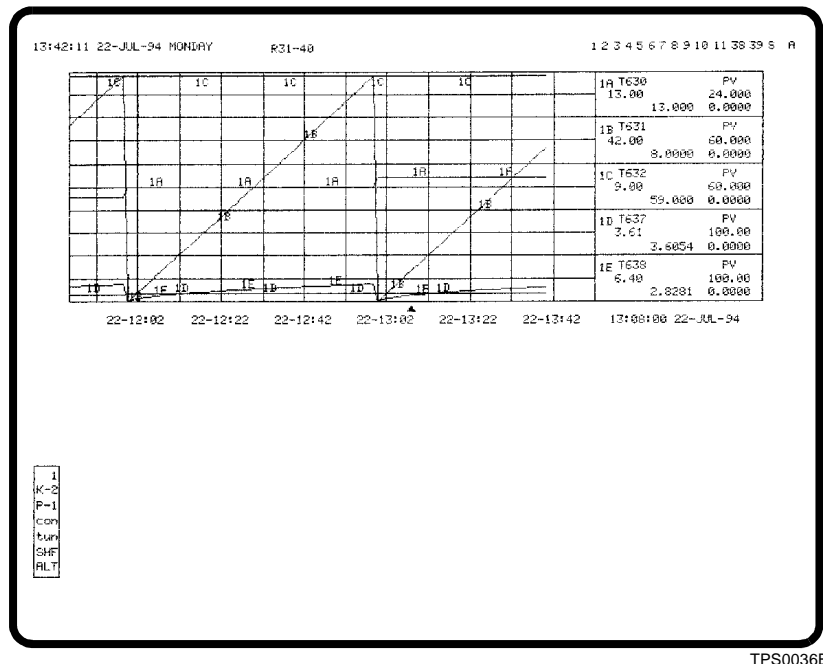

Figure 14-1. Trend Display

Each trend element on a display can present historical data for up to five separate process variables. The display presents the historical data as a continuous line on an x,y graph. The x-axis is referenced to time and the y-axis is the value of the variable.

The trend line for each variable on the graph is identified by a specific color and alphanumeric label. A trend line is periodically updated as new data is collected. The display presents newly collected values along with the historical values to maintain the continuously running line. An interruption in data collection can be seen as a break in the line.

Display Resolution

Collection resolution refers to the amount of time between data samples being collected by a PCU module. A 15-second collection resolution, for example, provides more detail than a one-minute resolution. Collection resolution is different than display resolution. Display resolution determines how often the trends on a display are updated. This is preset when a user-created display is built. The display resolution for an operator assignable trend display is two seconds. The display resolution for a trend element in an operator configurable display is either the least common multiple of the collection resolutions

for all trends in that element or the display resolution set in the definition of an enhanced trend. The resolution set for the enhanced trend is only used, however, if it is a valid multiple of the collection resolutions for **all** trends in the element.

For example, if a trend element contains five trend lines and three have a collection resolution of one minute and two have a collection resolution of 15 seconds, the display resolution will be one minute.

Display Updates

For trends saved to disk, historical data comes from a data file stored on the hard disk. Data is retrieved from the file when a trend display is called. Any new data to update the display comes from the module. To update the display, either the module is continually polled for new trend data or exception reported data is used instead. This depends on the mode of collection and the type of trend.

Historical data is retrieved from a PCU module when a trend is a display only type. No data is saved by the console for this type of trend; therefore, no data comes from the hard disk. Approximately the last 30 minutes of data collected by the PCU module is retrieved for display only standard trends. The amount of data retrieved for a display only enhanced trend depends on the number of events being saved by the module. As new data is received, any historical data remains until exiting the display.

When a trend display is called, the console also connects to the tag associated with the trend. It does this to update some dynamic attributes of the element. After the display is removed, the console disconnects the tag.

NOTE: An enhanced trend has a minimum collection resolution of one second. Under heavy load conditions, the console may not be able to update the data for a trend display every display resolution period. No data is lost in this case, only delayed.

Trend Attributes

Normally, the attributes of a trend line appear at the right of the trend element (Figure 14-1). The color and alphanumeric of a trend line associate it with the attributes shown in one of the five boxes at the right of the display. For example, a trend line in green with an alphanumeric of *IC* corresponds to the trend attributes box with a green, *IC* selector.

Figure 14-2 identifies the attributes that appear for a trend. Some fields do not appear until after selecting a trend element for control.

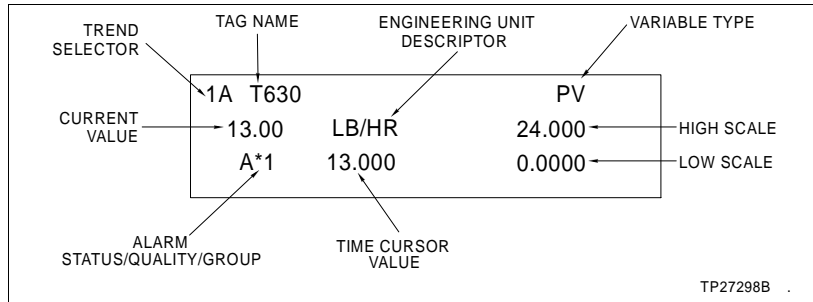

Figure 14-2. Trend Attributes

During trend definition, a tag name is entered in one of the trend definition fields. The name is of the tag that references the PCU module function block (process variable) for which a trend block is collecting data. This tag name is required to connect to the point to present real-time, dynamic information associated with the trended variable. The dynamic information includes alarm status, quality, dynamic value, etc.

Alarm Status/Quality/Group

An alarm status/quality/group field shows the alarm information currently being reported for the variable (tag). All normal alarm indications appear in this field. An alarm can be acknowledged using normal alarm processing procedures. Refer to [Section 12](#) for the alarm processing procedures and an explanation of alarm conditions and indications.

Current Value

The current value is the value currently being reported for the process point. The field updates to reflect any current changes in the process variable.

Engineering Unit Descriptor

The engineering unit descriptor (EUD) is the unit of measurement for the variable. A PCU module reports an EUD index number to select the appropriate engineering unit descriptor.

High and Low Scale Limits

The scale limits appear in two ways. For user-created trend displays, the limits are set during display creation. The limits are the zero and span values received in an exception report for a point when the trend element is part of an operator configurable display or an operator assignable trend display. The limits can be changed after calling the trend display to adjust the presentation. These are local display changes only. A scale limit change does not affect the display configuration or PCU module zero and span.

Tag Name

The tag name is the name of the tag associated with the trend. The tag is identified during trend definition.

Time Cursor Value

The time cursor value field shows the historical trend value at which the cursor is positioned. The value changes as the cursor is moved. The field also identifies with text the reason for any gaps or missing trend data. Table [14-1](#) lists and describes the indications given.

Table 14-1. Trend Data Error Messages

Message	Description
Resolution Invalid	Display resolution time (e.g., 15 seconds) defined for the trend element is less than the collection resolution (e.g., one minute) of a trend in the display. This occurs if the display resolution has not been defined correctly during display creation.
Not In Yet	A request for data was made but the data has not been processed or received yet.
Not Connected	Cannot connect to the tag associated with the trend. This occurs if the tag type has been changed, or the tag has been deleted from the tag database. It also occurs if the tag index, trend mode, or tag subtype has been changed in the trend database, or a trend has been deleted from the trend database while the trend display is on the screen.
Stats Suspect	At least one value used in a statistical calculation had bad quality.
Missing	Data is not available on the console. This is not an error. It appears when the console does not have access to the requested data since it is not stored on the hard disk. This normally occurs if the display is panned to a point past the data stored on the hard disk.
Not Retrieved	Data is not currently available on the console, but it should be available due to a past archive to media. The data must be retrieved using archive data retrieval procedures. Refer to Section 19 for the procedures.
Not Available	Data is not currently available on the console and an attempt to retrieve the data from archive media was made but unsuccessful due to bad data on the archive media.
Data Error	Error encountered during an attempt to read trend data retrieved from an archive media.
Invalid Trend	Trend display references an index number of an undefined trend. The trend index number the display is to use is determined during display creation.
Internal Error	Some internal processing error occurred.

Variable Type

The variable type field is configured as part of the symbol file used in creating the trend display. It identifies the type of variable being trended. Table 14-2 lists and describes the default variable type descriptors that appear in standard trend elements.

Table 14-2. Variable Type Descriptors (Trends)

Descriptor	Variable Type
CO	Control output
DG	Digital
PV	Process variable
RI	Ratio index
SP	Set point

Time Cursor

A time cursor does not appear until after selecting a trend element for control. A field showing the time cursor position appears directly below the trend attributes boxes (e.g., 13:00:08 22-MAY-96). This field identifies the current cursor position (Figure 14-1). The field updates as the time cursor is moved along the trend.

Time Span

The display presents a series of time increments along the bottom of the trend graph (Figure 14-1). A time increment appears at every other vertical scale line. For example, the time increments in Figure 14-1 appear as 22-12:02, 22-12:22, 22-12:42, etc. Each time increment is for the vertical scale line directly above it. The time increments shown in Figure 14-1 represent a time span of ten minutes between each line. This time span can be increased or decreased using trend zooming.

TREND CONTROL

Trend control features allow moving, expanding, shrinking, and magnifying a trend presentation. Trends, specifically distributed trends, can appear as part of a user-created display or in an operator configurable display. In either case, the functions available for manipulating the trend presentation remain and operate the same. The control features affect the display presentation only, not the PCU module configuration or stored trend data. Any changes made to the trend presentation remain in effect only while the trend element is on the screen.

NOTE: A trend element also appears in a tuning display and an operator assignable trend display. These displays do not present distributed trend data. The same type of information is presented, however.

Several options are available for calling a trend display. When a trend element is part of an operator configurable display, the miscellaneous menu *Display by Name* option is normally used. A user-created trend is normally called by name, from a keyboard function key, and from an annunciator display panel pushbutton.

Magnify

A magnifying glass feature highlights a limited section of the trend display. The glass can be used to determine the exact time and date a process disturbance occurred or a value more precisely without having to change the entire presentation. The trend inside the magnifying glass can be zoomed to increase or decrease the time span resolution. The time cursor can be moved within the glass to determine more exactly the time and date of a trended value.

Modify Scale Range	The high and low scale limits for each trend can be increased or decreased individually. The current data and any historical data to which the time cursor is moved displays in the newly entered scale range.
Move Time Cursor	The time cursor can be moved along the trend. This allows viewing a value at a specific time and date. The time cursor can also be aligned with a specific point on a trend line to determine the time and date that a process disturbance occurred. The time cursor can be moved by using a keyboard key or by panning. Each trend has a field that shows the historical trend value at the current position of the time cursor.
Pan	A pan function can be used to move the time cursor to show historical data. A field shows the time and date on which the time cursor is positioned.
Zoom	A zoom function can be used to expand or compress the time span of the element for easier trend analysis. Negative zooming decreases the time span between each vertical scale line, positive zooming increases the time span.

Enabling Trend Control

A trend element must first be enabled for active control before any trend control can be initiated. All trend control keys are located in the cursor and trend control keyboard section. Refer to **KEYBOARD LAYOUT** in Section 3 for their location.

Press the keys indicated by the alphanumeric selector of a trend or use a touch point to enable a trend element. Any of five possible selectors for a single element can be selected to enable the trend element. For example, if an element contains selectors *1A* through *1E*, **1** then **C** can be pressed to enable control for the entire element. The trend element outline highlights and a time cursor and additional fields appear after an element has been enabled.

Press **ESC** at any time to disable trend control. Disabling trend control resets the display back to its original default presentation.

Moving the Time Cursor

The time cursor and fields related to the time cursor appear after selecting a trend element for control. The time cursor appears along the bottom of the trend graph. The time cursor can be moved along the graph to view historical, trended values. Initially, the time cursor positions at the right of the graph at its home position.

A field showing the time cursor position appears under the trend attributes boxes (Figure 14-2). It indicates the time and

date on which the cursor is located. When the cursor is at its home position, the field updates as new data reports are received. The field shows the time and date of the most recently received data. It updates at intervals dependent on the display resolution. The displayed time and date also increment or decrement as the time cursor is repositioned.

To move the time cursor, press:



Moves back in time.



Moves forward in time.

These keys are normally used to move the cursor in small increments. The panning options can be used to make significant changes in the time cursor position.

The amount of time that each press of these keys moves the cursor depends on the time span (or zoom factor) of the graph. For example, if the time span between each vertical scale line is ten minutes, each press of a key moves the cursor one minute.

Press **HOME** to reset the cursor to its home position.

Modifying the Scale Range

When a user-created trend display is first called, the scale range for each trended variable is the range set during display creation. For an operator configurable or operator assignable trend display, the limits, in most cases, will all be different. This is because the high and low scale limits for each trend reflect the zero and span values set in the function block providing the variable. The variation in scale limits may or may not be desired. The scale limits in user-created, operator configurable, and operator assignable trend displays can be adjusted.

To change the scale limits for a trend variable:

1. Enable the trend for control and select the trend control identifier (i.e., 1C) for the trend whose scale range is to be changed. An input cursor appears on the high scale limit of the selected trend.

While the input cursor is enabled, it can be moved to any scale limit in the active trend element by pressing **TAB** or **TAB BACK**.

2. Enter a new high and low scale limit, then press **ENTER**. Both the high and low scale can be changed or only one limit if

desired. Any current and historical values for the trend will display in their newly entered range limits.

3. Press **ESC** to remove the input cursor.

NOTE: Remove the input cursor when finished. Some trend control functions cannot be performed while it is on the screen.

The scale limits return to their original values after exiting the display. On the next display call-up, the scale ranges will again be the default values.

Panning

Panning can be used for a trend display to quickly move the time cursor backward or forward in time or to move it to a specific time and date. Figure 14-3 shows a trend display with panning enabled.

An option available during trend display creation is to have the element display an update window. This window can be seen in Figure 14-3. As the time cursor is panned back to a historical time and date, the window continually updates to show current trend data from newly received reports.

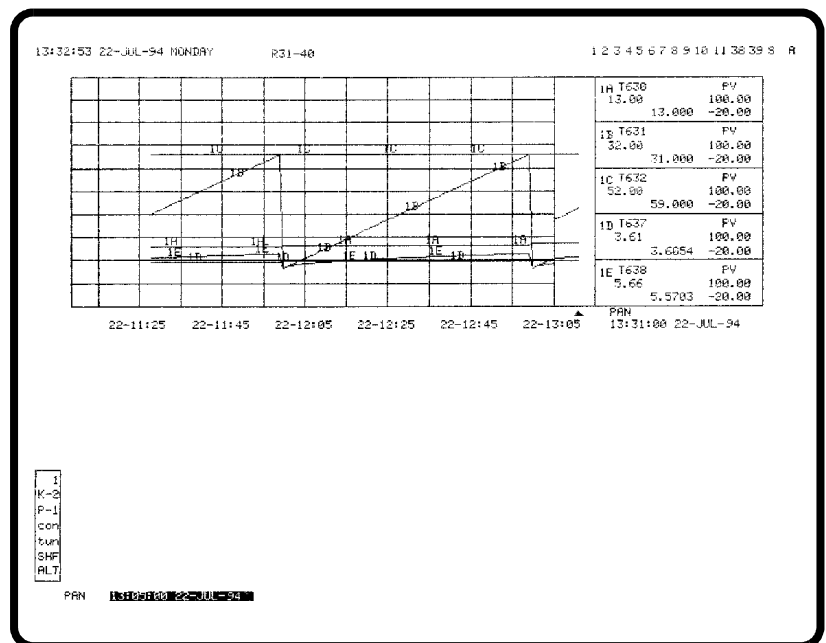

TPS0033B

Figure 14-3. Trend Display - Panning Enabled

To pan to a specific time and date:

1. With the element enabled, press **PAN**. A PAN field appears at the lower left corner of the window (Figure 14-3).

2. Enter the time and date of the historical data to view, then press **ENTER**. The trend display will update and position the time cursor on the entered time and date.
3. Press **ESC** to clear the *PAN* field.

NOTE: Remove the *PAN* field when finished. Some trend control functions cannot be performed while it is on the screen.

To randomly pan backward or forward in time, with the element enabled, press:



Moves backward in time to view historical data.



Moves forward toward the current time and date.

When using the keys, the amount of time panned depends on the current time span (or zoom factor) of the display. Generally, each press moves the display backward or forward $\frac{1}{2}$ the time span of the entire trend graph. For example, if the entire time span is one hour, pressing either key displays the next or previous 30 minutes of data.

PAN appears under the trend attributes boxes to indicate that the element has been panned (Figure 14-3). The display can be zoomed while the display is panned.

Press **HOME** to reset the time cursor and display back to the current time and date. This disables panning and removes the *PAN* indication and update window.

Zooming

Zooming for a trend display increases or decreases the amount of trend data (trend line) displayed. Figure 14-4 shows a trend display with zooming activated.

Zooming changes the trend presentation by increasing or decreasing the time span thereby decreasing or increasing the amount of trend line presented. Positive zooming increases the time span or amount of time between each vertical scale line, which makes the presentation look like it is contracting. Negative zooming is just the opposite.

Zooming can be performed in two ways. The display can be zoomed by entering a zoom factor from 9 to -9, or it can be zoomed using keyboard keys.

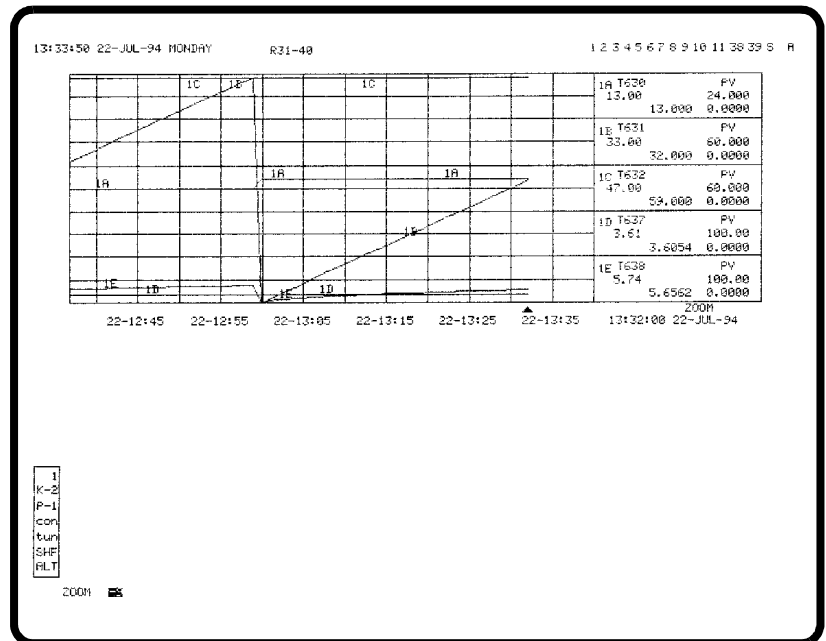

TPS0034B

Figure 14-4. Trend Display - Zooming Enabled

To enter a zoom factor:

1. With the element enabled, press **ZOOM**. A **ZOOM** field appears at the lower left corner of the window (Figure 14-4).
2. Enter a zoom factor from 1 to 9 to perform positive zooming or -1 to -9 for negative zooming, then press **ENTER**.
3. Press **ESC** to clear the **ZOOM** field.

NOTE: Remove the **ZOOM** field when finished. Some trend control functions cannot be performed while it is on the screen.

To randomly zoom, with the element enabled, press:



Performs positive zooming.



Performs negative zooming.

The amount of zoom per keystroke depends on the current time span of the display.

ZOOM appears under the trend attributes boxes to indicate that the element has been zoomed (Figure 14-4). The display can be panned while the display is zoomed.

Press **HOME** to reset the display back to its original time span. This disables zooming and removes the **ZOOM** indication.

Using the Magnifying Glass

A magnifying glass can be enabled at any time to highlight a portion of the trend graph. It can be used to determine a time and date or a value more accurately without having to change the entire display presentation. After being enabled, the time cursor within the magnifying glass can be moved and the trend line within the glass can be zoomed for more accurate analysis. Figure 14-5 shows a trend display with the magnifying glass enabled.

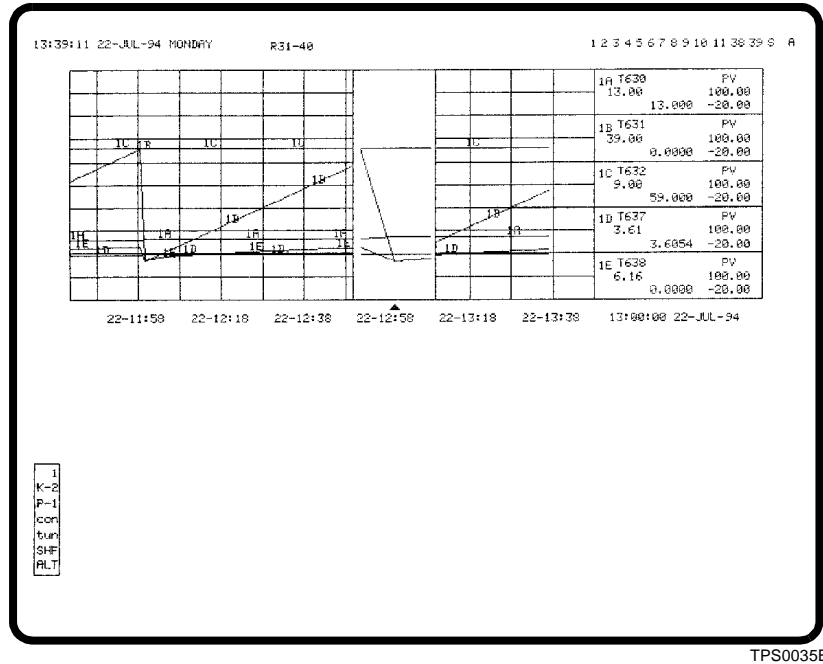
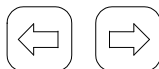

Figure 14-5. Trend Display - Magnifying Glass Enabled

The initial amount of trend line displayed in the magnifying glass depends on the zoom factor set for the element. The glass can be zoomed to show a two-minute segment of the trend line.

To enable the magnifying glass:

1. With the element enabled, position the time cursor on the desired trend segment to analyze. Either use the keys or panning to move the time cursor. The cursor must be moved from its home position to enable the glass.
2. Press **ENTER**. The glass appears at the position of the cursor.
3. To fine tune the glass position, press:



4. When in the desired position, the magnifying glass must be made active to allow its inside operations. Press:



Press **ESC** or **HOME** to remove the magnifying glass. **HOME** both removes the glass and returns the display to its original presentation. **ESC** removes the glass while leaving the display as is.

Zooming To zoom inside the magnifying glass, press:



Performs positive zooming.



Performs negative zooming.

Time Cursor The time cursor can be moved within the glass in the same way as it can be when outside the glass. A pan can be performed within the glass, but only with the panning keys. The amount of pan depends on the zoom factor of the glass.

OPERATOR ASSIGNABLE TRENDS

The *Operator Assignable Trends* option allows the creating two types of trends: A tag trend that trends a variable that is defined as a tag in the database and a function block output trend. The block output type can be used to trend most types of function blocks in a PCU module even if a block is not defined as a tag. Some blocks cannot be defined as tags since they do not exception report values.

Operator assignable trends do not require a trending block in the PCU module. Therefore, they do not use data collected by the INFI 90 OPEN distributed trending system. The data collection method and resolution also differ from that of distributed trends. The console collects and stores the data rather than a PCU module. Data collection occurs every two seconds for each operator assignable trend, which makes trend resolution two seconds. Up to two hours of trended data can store on the hard disk. Operator assignable trends are also referred to as **fast trends**.

Operator Assignable Trends Display

Two operator assignable trend displays are provided. Each standard display has two ½-size trend elements. The custom trend displays can be sized to meet requirements. Refer to **TREND DISPLAY** in this section for an explanation of the information presented in an operator assignable trends display and the operations that can be performed from this display.

Up to five trends can appear on a single trend element. Up to 20 operator assignable trends can be created. There are, however, some guidelines that must be followed when creating these trends. The following sections provide further explanation.

Trend Assignments

Operator assignable trends can be defined in three ways:

- Access the *Operator Trend Assignment* screen by the use of the system menus (refer to **OPERATOR TREND ASSIGNMENT OPTION** in this section).
- Use the pull down menus to access the **OPERATOR ASSIGNABLE TREND ASSIGNMENTS WINDOW** and manually enter the trend data.
- Assign trends automatically from a graphic display using the *Operator Assignable Trend Assignment* window (refer to **AUTOMATIC TREND ASSIGNMENTS** in this section).

An operator assignable trend must first be defined before the console can begin collecting any data. There are actually two trend assignment pages. Both pages are the same except that the first page defines *LIST 1* and *LIST 2* trends, the second page *LIST 3* and *LIST 4*. Each list defines the trends that appear in a single trend element, five trends per element.

Data can be collected, stored, and displayed for up to 20 operator assignable trends. The 20 can be a mix of tag and block output type trends. Only six of 20 can be block output trends. For example, if six block output trends are defined, then the 14 remaining can only be tag trends. Each display and trend element can display any combination of trend types.

Operator assignable trends are used in the trend element of a tuning display. The trend element of the tuning display presents three variables which count as three block output trends. If two tuning tags are active, at least one must be cleared to define any block output trends. Both displays must be cleared to define more than three block output trends.

Conversely, deleting some block output trends may be required to call a tuning display. If there are three or less block output trends, one tuning display can be active. If there are four or more, a tuning display cannot be called.

The *TUNING TAG #1* and *TUNING TAG #2* fields have two purposes. They indicate whether there are active tuning displays, and they allow clearing or deactivating collection for tuning displays. The only valid operation to perform for these fields is to clear them. This clears a tuning display making room for

additional operator assignable trend entries or another tuning display.

OPERATOR TREND ASSIGNMENT OPTION

An operator assignable trend must first be defined before the console can begin collecting any data. To call the display used to define an operator assignable trend (Figure 14-6), first press **GENL FCTNS MENU**, then select the following menu items in the sequence shown.

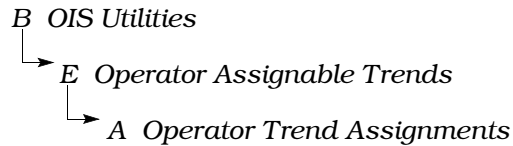

14:26:42 OCT 03, 1996 THURSDAY OPERATOR TREND ASSIGNMENT

LIST 1

TAG NAME/INDEX	TYPE	LOOP	PCU	MODULE	BLOCK	LOW LIMIT	HIGH LIMIT
STR-08793 8793	PV	1	150	5	257	-75.00	25.00
STR-08793 8793	SP	1	150	5	257	-45.00	55.00
STR-08793 8793	CO	1	150	5	257	-35.00	65.00
STR-08793 8793	RI	1	150	5	257	-25.00	75.00
5 SEC. SAMPLES		1	203	3	520	-1.00	1.00

LIST 2

TAG NAME/INDEX	TYPE	LOOP	PCU	MODULE	BLOCK	LOW LIMIT	HIGH LIMIT
SINE01-203-3		1	203	3	500	-2.00	2.00
SINE02-203-3		1	203	3	502	-2.00	1.00
SINE03-203-3		1	203	3	504	-1.00	1.00
SINE04-203-3		1	203	3	506	-1.00	2.00
SINE05-203-3		1	203	3	508	-1.00	3.00

TUNING TAG #1 : TUNING TAG #2 :

Use NEXT/PREV for other lists

1
K-1
P-1
GO
LIM
SHF

TPS0220C

Figure 14-6. Operator Trend Assignments Page

During definition, certain fields may or may not be accessible depending on the trend type. The fields to define for each type of trend are:

Tag trend - TAG NAME/INDEX, TYPE (STATION tag only), LOW LIMIT, and HIGH LIMIT.

Block output trend - LOOP, PCU, MODULE, BLOCK, LOW LIMIT, and HIGH LIMIT.

Defining a Trend

Four lists of trends with up to five trends per list can be defined. Each list defines the trends that appear in a single trend element of an operator assignable trends display. Each trend is a separate line on the trend graph identified by a specific color and alphanumeric.

Press **NEXT PAGE** or **PREV PAGE** to sequence between the two trend assignment pages.

To define or edit a trend:

1. Select a trend using the tab and arrow keys. The first trend on the list is selected on entry.
2. For a **tag trend**, define the following fields:

TAG NAME/INDEX - enter the tag name or index number of the desired tag to trend. This must match a tag defined in the tag database. If an index number is entered, the entry is automatically updated to a tag name after moving from the field. The remaining fields are filled in after pressing **ENTER** or moving to another field. The address fields of a tag trend cannot be accessed.

TYPE - the type must be specified for a STATION tag. This determines the station variable to trend. The options are:

- SP** - set point
- PV** - process variable
- CO** - control output
- RI** - ratio index

If the type is not specified for a STATION tag, the variable that will be trended by default is the process variable (PV).

For a **block output trend**, define the following fields:

LOOP, PCU, MODULE, and BLOCK - enter the function block address of the block output to trend. The *BLOCK* field determines which block output the console is to trend.

The function block address is checked to see if it matches any configured tags after entering. If a match is found, a tag name is automatically entered and the trend becomes a tag trend.

The *LOW LIMIT* and *HIGH LIMIT* fields are automatically filled in for either type of trend. These fields set the scale limits the trend element initially uses. The limits can be adjusted from this display or can be left as is and adjusted later after calling the actual operator assignable trend display. If set here, the display defaults to these limits every time it is called.

3. Press **ENTER** to save the information. If required, press **NEXT PAGE** or **PREV PAGE** to define the other trend lists.

Call an operator assignable trend display to see the results of these entries. Separate menu options are available for calling the list one and two trends and the list three and four trends. Refer to **Calling the Trend Display** in this section for the procedures.

Deleting a Block Output Trend

To delete a block output trend:

1. Clear any one of its address fields.
2. Move out of the field, then press **ENTER**

Deleting a Tag Trend

To delete a tag trend:

1. Clear its *TAG NAME/INDEX* field.
2. Move out of the field, then press **ENTER**

Deleting a Tuning Tag

A tuning tag must be deleted in some cases to define block output trends. Each tuning display counts as three block output trends. If a tag name appears in a *TUNING TAG* field, a tuning display is active for that tag. Refer to **TUNING DISPLAY** in Section 11 for information about a tuning display.

If two tuning displays are active, a block output trend cannot be defined. To make room to enter a block output trend, delete a tuning tag:

1. Position the input cursor on the selected tuning tag using the tag or arrow keys.

NOTE: If the tuning display is currently called in another window, it cannot be cleared.

2. Press **CLEAR**. This is the only valid option for either tuning tag field.
3. Press **ENTER** to initiate the deletion and to clear the tuning display.

AUTOMATIC TREND ASSIGNMENTS

Trends can automatically be assigned from a graphic display using the *Operator Assignable Trend Assignment* window (Figure 14-7). To automatically assign a tag to a trend:

1. Select a tag on a graphic display.
2. Activate the *Operator Assignable Trend Assignment* window using the *Utilities* pull-down menu, touch pad or touch point.

The operator trend assignment dialog box will appear with the selected tag in the *Selected* field and to the first available *Tagname/Index* button. If no buttons are available or if no tag is selected in the graphic, the trend assignment list one and two will be displayed but no button will be assigned the selected tag. The editing of the fields in the operator assignable trends window is described in **OPERATOR ASSIGNABLE TREND ASSIGNMENTS WINDOW** in this section.

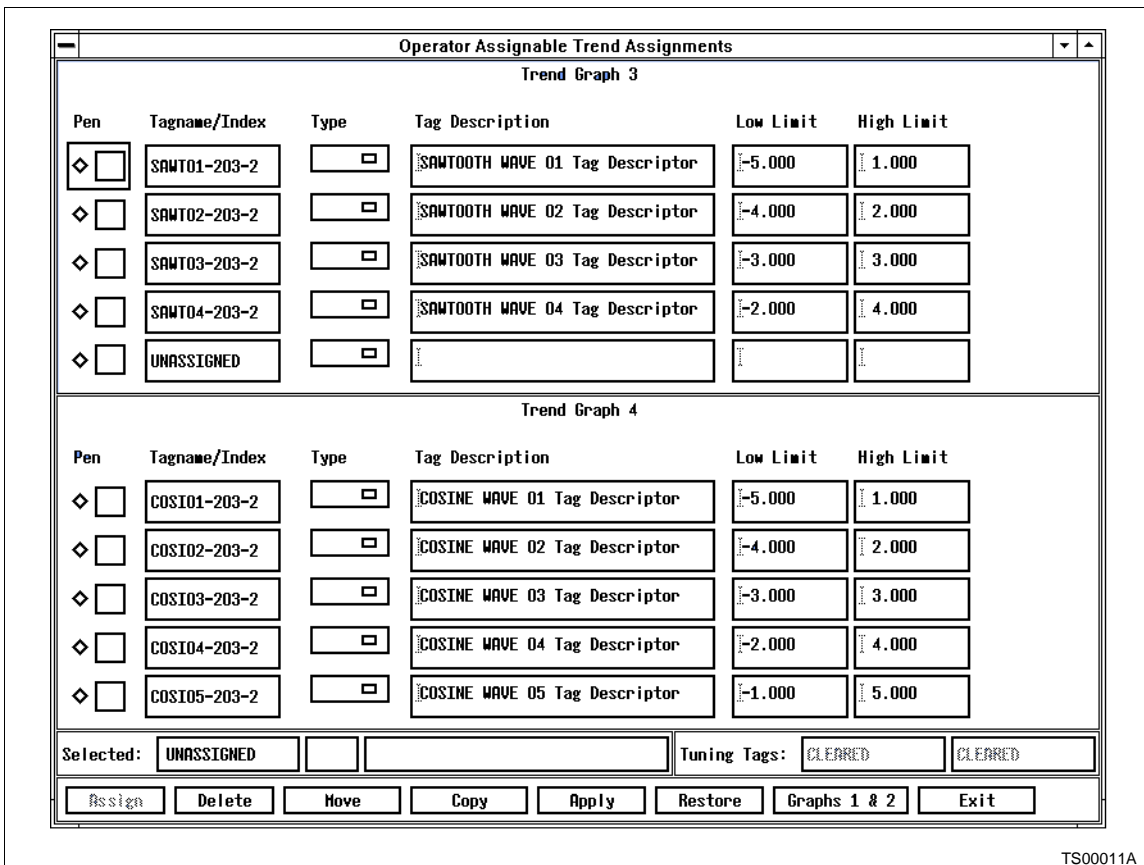

Figure 14-7. Operator Assignable Trend Assignments Window

OPERATOR ASSIGNABLE TREND ASSIGNMENTS WINDOW

To manually assign trends in the *Operator Assignable Trend Assignment* window select *Operator Trend Assignment* from the *Utilities* pull-down menu or touchpad key. The *Operator Assignable Trend Assignments* window will open with the tag list containing the first available pen. To switch to the tag lists for graph three and four click on *Graphs 3 & 4*.

The *Operator Assignable Trend Assignments* window displays the pen color, tag name index, type, tag description and high and low scale limits for each configured trend. There is two assignable tuning tags available.

Assigning a Trend

There are five assignable trends for each trend graph and four graphs. Each trend can be assigned a tag name or a block output.

To configure a trend:

1. Click on an unassigned button in the *Tagname/Index* list. This invokes the *Operator Assignable Trend Detail* dialog box (Figure 14-8).
2. For a **tag trend**, enter the tag name to be used as the source of data for the trend in the *Tagname/Index* field.

For a **block output**, enter the hardware address for the block in the *Loop, PCU, Module* and *Block* fields. These fields are only available only if the *Tagname/Index* field is left blank.

In the *Selected Pen Color* area is a series of color samples for the trends. Select a color by clicking on the toggle button beside the desired color sample. A pen icon in the color sample indicates that the color is being used for a trend in the selected graph.

Figure 14-8. Operator Assignable Trend Detail

Validate Trend After a trend has been entered *Validate* can be used to verify the information entered in the *Operator Assignable Trend Detail* fields. If a hardware address has been entered and it corresponds to a valid tag, the *Tagname/Index*, *Tag Description* and *Cust. Description* fields will be updated. If a valid block address that does not correspond to a tag address is entered, the address label appears in the *Tagname/Index* field. When a valid tag is entered, the tag information fields will be updated. If an invalid tag name or block address has been entered an error message will be displayed.

Clear Trend Click on *Clear* to erase the tag information for the configuration of a new trend.

Close Trend Detail Click on *Close* to return to the *Operator Assignable Trend Assignments* window. When the window is closed the tag information is verified as described in previously. If the *Tagname/Index* and *Block Address* fields are blank when close is clicked the trend will be deleted from the list.

Data Type Selection

Type is only enabled for STATION tags. Click on this button to display a list box of data types and select the desired one for the trend. The data types for each tag are shown in.

- SP - set point.
- PV - process variable.
- CO - control output.
- RI - ratio index.

The default value is process variable.

Low Limit/High Limit

The *Low Limit* and *High Limit* values set the scale limits of the trend. To edit the limits click on the field and enter the desired limits for the selected trend.

Copying

To copy the tag values of a configured trend:

1. Click on the toggle button of the trend that is to be copied.
2. Click on *Copy*.
3. Select the toggle button of the destination trend.
4. Click on *Assign*.

Moving

To move the tag values of a configured trend to another:

1. Click on the toggle button of the trend that is to be moved.
2. Click on *Move*.
3. Select the toggle button of the destination trend.
4. Click on *Assign*.

Deleting

To delete the tag values of a configured trend:

1. Click on the toggle button of the trend that is to be deleted.
2. Click on *Delete*. A confirmation pop-up displays.
3. Click on *OK*.

Deleting a Tuning Tag

A tuning tag must be deleted in some cases to define block output trends. Each tuning display counts as three block output trends. If a tag name appears in a *TUNING TAG* button, a tuning display is active for that tag. Refer to **TUNING DISPLAY** in Section 11 for information about a tuning display.

If six block output trends are active, a new block output trend cannot be defined. To make room to enter a block output trend, delete a tuning tag:

1. Click on the button of the tuning tag that is to be deleted. A confirmation pop-up displays.
2. Click on *OK*.

Restore Saved Trends

To restore the trends from the operator trend assignment configuration file:

1. Click on *Restore*. A confirmation pop-up displays.
2. Click on *OK*.

Saving Changes to the Trends

To save the changes to the operator trend assignment configuration file and apply the changes to the operator trend display:

1. Click on *Apply*. A confirmation pop-up displays.
2. Click on *OK*.

Calling the Trend Display

An operator assignable trends display can be called at any time by menu selections. Two separate trend displays can be called. The first is for *LIST 1* and *LIST 2* trends and the second is for *LIST 3* and *LIST 4* trends.

To call an operator assignable trend display, first press **GENL FCTNS MENU**, then select the following menu items in the sequence shown.

```

B OIS Utilities
  |
  |> E Operator Assignable Trends
      |
      |> B Trend Display List 1 & 2
  
```

- or -

```

B OIS Utilities
  |
  |> E Operator Assignable Trends
      |
      |> C Trend Display List 3 & 4
  
```

PRINT TREND LIST

A print trend list utility can be used to print a complete or partial list of trend definitions. The utility has several options to select which trends are to appear in the printout. The menu option determines the trend definition attribute that will be searched for when compiling the trend list. A list based on any of the following attributes can be compiled:

Tag name - process tag associated with a trend.

Trend type - normal (one-minute standard trends), fast (15-second standard trends), enhanced, or undefined.

Collection mode - sample, average, minimum, maximum, sum, or range.

Trend usage - display only, save to disk, archived, or external source trends.

Module address - all trends within a single module.

Tag type - either analog or digital trends.

A trend list printout occurs at the printer assigned to the window. Look at the keyboard status block to determine which printer.

Use the *Trend List* option to initiate a trend list printout. Figure 14-9 shows the display used. To call this display, first press **GENL FCTNS MENU**, then select the following menu items in the sequence shown.

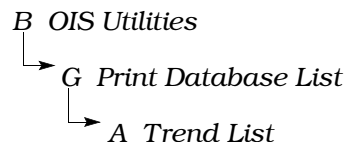

The trend list menu has options for specifying a trend index range. The fields at the top of the page indicate the current range. Use options *G* and *H* to set the range. Initially, the default is the entire trend index range.

Setting the Range

The trend index range can be used to limit the printout to only trend definitions within a certain index range. This is only necessary if the current range shown at the top of the page is not the desired range. To specify a range:

1. Select *G Enter Start Trend Index*. This positions an input cursor on the *Start Trend Index* field.

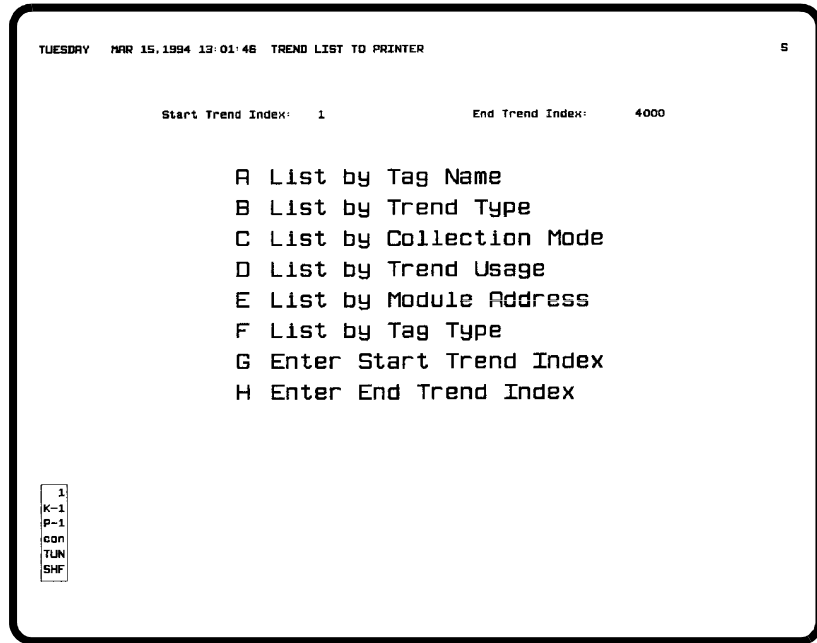

TPS0107C

Figure 14-9. Trend List to Printer Page

2. Enter the index number of the first trend definition that is to appear in the printout, then press **ENTER**
3. Select *H Enter End Trend Index*. This positions an input cursor on the *End Trend Index* field.
4. Enter the index number of the last trend definition that is to appear in the printout, then press **ENTER**. The index number of the ending trend definition must be equal to or greater than the starting index number.

The index range to print a complete trend list depends on the maximum number of trends.

Selecting the Trends to Print

Options *A* through *F* select the trend definitions that are to appear in the printout. A trend list is compiled by checking each trend definition for the selected attribute. The range is also referenced when compiling a trend list.

After initiating a trend list print, the list is compiled then formatted for printing. The following message indicates the page currently being processed:

Processing page n

Exiting after making a selection and while the message is displaying causes the printout to stop.

If trend definitions within the range that match the selected type cannot be found, the following message appears:

Nothing in Range to Print w/this Option

LIST BY TAG NAME

To compile a listing of trends by tag name:

1. Press **A**. A *Tag Name or Index* field appears.
2. Enter a tag name or index number, then press **ENTER**

LIST BY TREND TYPE

To compile a listing of trends by type:

1. Press **B**. A submenu appears.
2. Press one of the following keys:
 - A** - normal trends (one-minute standard trends).
 - B** - fast trends (15-second standard trends).
 - C** - enhanced trends.
 - D** - undefined trends.
 - ESC** - returns to the trend list menu.

LIST BY COLLECTION MODE

To compile a listing of trends by collection mode:

1. Press **C**. A submenu appears.
2. Press one of the following keys:
 - A** - sample collection mode trends.
 - B** - average collection mode trends.
 - C** - minimum collection mode trends.
 - D** - maximum collection mode trends.
 - E** - sum collection mode trends.
 - F** - range collection mode trends.
 - ESC** - returns to the trend list menu.

LIST BY TREND USAGE

To compile a listing of trends by usage:

1. Press **D**. A submenu appears.
2. Press one of the following keys:
 - A** - display only usage type trends.
 - B** - save to disk usage type trends.
 - C** - archived usage type trends.
 - D** - external source usage type trends.
 - ESC** - returns to the trend list menu.

LIST BY MODULE ADDRESS

To compile a listing of trends by module address:

1. Press **E**. The following prompt appears:

LOOP ___ PCU ___ MODULE ___
2. Enter the desired module address, then press **ENTER**

LIST BY TAG TYPE

To compile a listing of trends by tag type:

1. Press **F**. A submenu appears.
2. Press one of the following keys:
 - A** - analog tag type trends:

ANALOG	RMSC
DAANALG	STATION
DANG	
 - B** - digital tag type trends:

DADIG	MSDD
DD	RCM
DIGITAL	RMCB
 - ESC** - returns to the trend list menu.

SECTION 15 - XY PLOT OPERATIONS

INTRODUCTION

The XY plot function can be used to plot pairs of process variables in an x,y graph format for process analysis. The x-axis is determined by one process variable, the y-axis another.

Three types of plots can be created. The data source defined for a plot determines whether the data is exception reported tag values (tag source), distributed trend data (trend source), or values collected by a program running in a multi-function processor module (MFC source). The data source for a plot is selected during XY plot definition. Up to 80 indexed plots can be defined.

TAG OR TREND XY PLOT

The variables that appear in a tag or trend type of XY plot depend on the plot definition used in the display. Each plot definition defines the data for a single plot. The characteristics of a tag or trend plot are set up during plot definition. Specifically, plot definition identifies:

- Data source (tag data or trend data).
- Initial update mode.
- X-axis variable.
- Y-axis variable.
- Initial x-axis and y-axis high and low limits.
- Conditions that control plot clearing.
- Data collection resolution.
- Maximum number of samples.

Refer to the discussion on XY plot definition in the **Configuration** instruction for an explanation of data source and for the procedures to define a plot (Table 1-2 lists instruction numbers). Also, the instruction explains XY plot display configuration requirements.

Plot Display

Standard XY plot display templates in varying sizes are provided. These sizes range from a full size display to ½-size. An XY plot display is normally called by name, from a keyboard function key, and from an annunciator display panel pushbutton. Figure 15-1 is an example plot display. The display was created using the **XPFL5.DT** source file.

A single XY plot element can present data for up to five pairs of variables. The data plots as either a single point, a series of

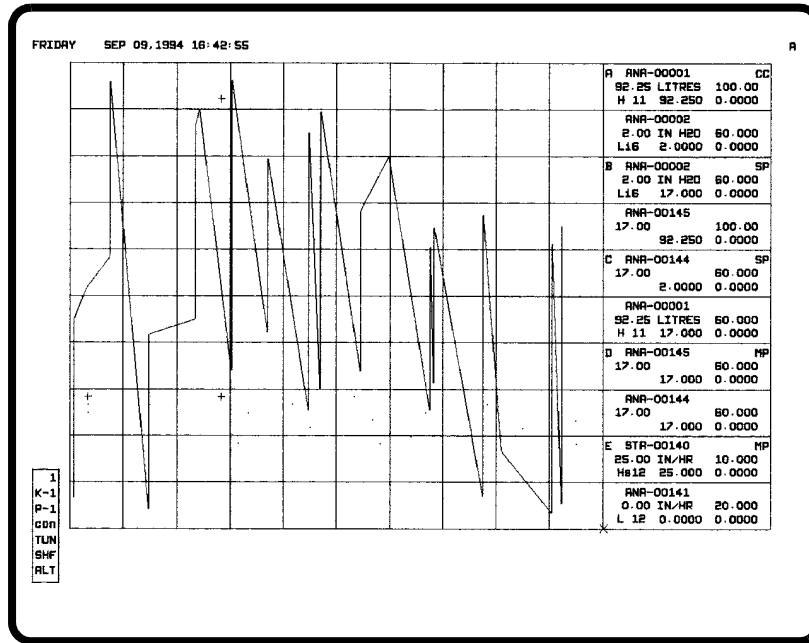

TPS0047C

Figure 15-1. XY Plot Display

dots, or a continuous line on an x,y graph. A cross hair (+) pointer indicates the most recently plotted point. The position of the pointer updates as new values are received. Each plot and its pointer are identified by a specific color on the graph.

The resolution of a plot determines how often the display updates. Data is collected at a rate set during plot definition. The definition pages allow activating or deactivating data collection. For a tag plot, the resolution can range from seconds to days. A trend plot resolution is either 15 seconds or one minute.

Plot Attributes

The attributes of a plot appear at the right of the display (Figure 15-1). The color of a plotted point associates it with a pair of attribute boxes. For example, a plot in green corresponds to the attribute boxes identified with a green selector. The top box in the pair contains the x-axis attributes. The bottom box in the pair contains the y-axis attributes. Figure 15-2 identifies the attributes that appear for each variable of a tag or trend plot.

During plot definition, two tag names are entered: One for the x-axis variable and the other for the y-axis variable. The name is of the tag that references the function block from which the plot is collecting data. These tag names are required to present real-time, dynamic information for each variable of a plot. The tags are required whether the plot is a tag or trend plot.

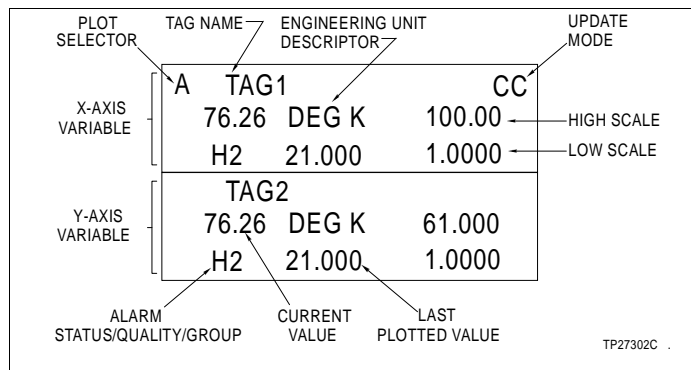

Figure 15-2. XY Plot Attributes

Alarm Status/Quality/Group

An alarm status/quality/group field shows the current alarm information being reported for the variable (tag). All normal alarm indications appear in this field. An alarm can be acknowledged using normal alarm processing procedures. Refer to [Section 12](#) for alarm processing procedures and for a description of alarm conditions and indications.

Current Value

The current value is the value currently being exception reported for the process point. The field updates to reflect any changes in the process variable.

Engineering Unit Descriptor

The engineering unit descriptor (EUD) is the unit of measurement for the variable. A PCU module reports an EUD index number to select the appropriate engineering unit descriptor.

High and Low Scale Limits

Initially, the scale limits are the high and low scale limits entered during plot definition. These limits can be changed to adjust the presentation after calling a display. These are local display changes only. A scale limit change does not affect the plot definition.

Last Plotted Value

The last plotted value is the most recently plotted value. The field updates as each new value is plotted.

Plot Legend

A legend can be incorporated into a custom XY plot display during its creation if desired. The plot definition defines the text of the legend.

Tag Name

The tag name is the name of the tag associated with the plot. This is the tag entered during plot definition.

Update Mode

An update mode indicator identifies the current mode for the plot. The initial indication is the update mode set during plot definition.

It can be temporarily changed using plot functions. The mode indicator appears as:

SP - single point
MP - multipoint
CC - continuous curve
OC - operating curve

Plot Control

XY plot control options can be used to adjust the plot presentation, specifically the scale limits and update mode. The changes made while a plot display is on the screen are temporary. After exiting, the display resets to its default presentation for the next call-up.

SELECTING A PLOT

The control features function on a per plot basis. To change the presentation with the control commands, select one of the plots. Press the key identified by the selector character or use a touch point. An *X TARGT MODE* field appears and the element highlights when selected. The control prompt location depends on parameters defined during display creation, but normally it appears under the attributes boxes. The *X* portion indicates the currently selected and active plot for control (i.e., *A*, *B*, *C*, *D*, or *E*). The following sections explain the control options for a plot.

SETTING THE SCALE LIMITS

The scale change command (SC) adjusts the high and low scale range. To change the scale limits for a selected plot:

1. Enter **SC** in the *X TARGT MODE* field, then press **ENTER**. An input cursor appears on the high scale limit of the plot. After the input cursor is enabled, it can be moved between the scale limits by pressing **TAB** or **TAB BACK**.
2. Enter a new high and low scale limit, then press **ENTER**. Both the high and low scale can be changed or only one limit if desired. Any current and historical values will conform to the newly entered range.
3. Press **ESC** to remove the input cursor.

CHANGING THE MODE

A plot defaults to the update mode set during its definition. Plot options allow changing the update mode while the plot is on the display.

The update modes are:

Single point (SP) - the plot is updated as a single point. The most recently plotted value is identified by the cross hair (+). Historical points do not appear in this mode.

Multipoint (MP) - all plotted points remain on the screen as a series of dots. The most recently plotted point is identified by the cross hair.

Continuous curve (CC) - all plotted points connect as a line. The most recently plotted point is identified by the cross hair.

Operating curve (OC) - all plotted points are connected in the order that they are received. The most recently plotted point is identified by the cross hair.

For the continuous curve and multipoint plots, up to 480 samples can appear on the graph at one time. When the maximum is reached, the last plotted point scrolls off the graph.

A clear feature can be implemented during definition to clear plotted values after a certain trigger condition is met. If enabled, a plot will clear after a certain number of samples, after a specified amount of time, or when a trigger tag trips.

To change the mode of a selected plot, enter one of the following commands in the *X TARGT MODE* field, then press **ENTER**

- SP** - single point mode
- MP** - multipoint mode
- CC** - continuous curve mode
- OC** - operating curve mode

CALLING HELP

A help option (HP) is available at any time to call a list of valid XY plot commands. To call a list of plot options, enter **HP** in the *X TARGT MODE* field, then press **ENTER**. A partial list of available commands appears at the bottom of the window. Press **NEXT PAGE** or **PREV PAGE** to view the complete list. The plot options are:

- | | | |
|------------------------------|--------------------------|-----------------------------|
| <i>SC - Scale Change</i> | <i>HS - History</i> | <i>BF - Background File</i> |
| <i>SF - Save into File</i> | <i>ED - Edit File</i> | <i>CL - Clear the Plot</i> |
| <i>HP - Help</i> | <i>SP - Single Point</i> | <i>MP - Multi Point</i> |
| <i>CC - Continuous Curve</i> | | |

Plot Data Background Curve

A snapshot of the currently plotted data can be saved. The data is saved in a file with a user-defined name. After being saved, the plot data can be called back to the display as a

background plot at any time by entering its name. Each plot file contains information for a single plot, not the entire display. An option for editing this data or creating this background data is also provided.

Commands for saving, viewing, and editing plot data files are entered in the *X TARGT MODE* field. The commands include:

- SF** - save collected plot coordinates to file
- ED** - edit a file
- BF** - display a background file of plotted coordinates
- CL** - clear the background curve from plot the display

SAVING PLOT COORDINATES TO A FILE

The save to file (SF) command saves plot data to a file. To save the plotted data for a selected plot:

1. Enter **SF** in the *X TARGT MODE* field, then press **ENTER**. A *FILE NAME* field appears.
2. Enter a file name of up to eight alphanumeric characters, then press **ENTER**. The name given to a background file should be meaningful. Control returns to the *X TARGT MODE* field after the operation is complete.

The background files are kept in a single directory ((DATA.USN59)) in order to group them for transfer.

EDITING A FILE

The edit (ED) command builds or modifies a background file. To edit:

1. Enter **ED** in the *X TARGT MODE* field, then press **ENTER**. A *FILE NAME* field appears.
2. Enter the name of an existing file to edit or enter a new name to create a background file, then press **ENTER**. If the file exists, it displays on the graph as a background curve. If the file does not exist, a curve can be built.

An *XY: XXXXXX YYYYYY* field appears after entering the file name. The *XXXXXX* portion is the x-axis value and the *YYYYYY* portion is the y-axis value. The input field is used to edit the x- and y-axis values to either change the background curve or to build a background curve.

To edit the coordinates of a background file:

1. Press:



To move the input field between the coordinate fields. Key in a new coordinate value if desired.

2. Press **TAB** and **TAB BACK** to view the next or previous coordinate pair respectively. The display updates after pressing either key.
3. Repeat Steps 1 and 2 for each coordinate pair until the desired presentation is created.
4. Press **ENTER** to save all changes to the background file. Press **ESC** to abandon the changes and return control to the *X TARGT MODE* field.

DISPLAYING A BACKGROUND FILE

The background file (BF) command calls a previously saved set of coordinates. To call a background file:

1. Enter **BF** in the *X TARGT MODE* field, then press **ENTER**. A *FILE NAME* field appears.
2. Enter the name of a file that was created using either the **SF** or **ED** command, then press **ENTER**.

A continuous curve is drawn from the data contained in the background file. Its color is always white. The data from only one file can display at a time.

A background file can be deleted from the hard disk at any time. Refer to the **File Utilities** instruction for a description of the delete command (Table 1-2 lists instruction numbers).

CLEARING A BACKGROUND CURVE

The clear command removes the background curve from the plot. To clear a background curve, enter **CL** in the *X TARGT MODE* field, then press **ENTER**.

Trend History

The history command (HS) calls historical trend data for a trend plot. The data plots as a background curve. To call historical trend data:

1. Enter **HS** in the *X TARGT MODE* field, then press **ENTER**. An *X START TIME* field appears.
2. Enter a starting time and date, then press **ENTER**. For example:

18:50:45 13-APR-96

The retrieved data appears in a background curve. Use the **CL** command to clear the background curve.

MFC DATA SOURCE XY PLOT

An MFC data source plot uses data collected by a program running in a multi-function processor (MFP) module. The variables that are plotted come from a data file transferred to the console from the module. Normally, the MFP module executes a C language program to collect data. It sends the data to the console in real-two format.

A plot definition determines which data file is associated with a given plot. Each plot definition has a unique index number. Parameters defined during plot display creation reference the index number of a plot definition. This determines the data that is initially displayed when the plot display is called. Another data file can be selected for the display, however, at any time after calling the display.

A data file resides in the [DATA.USN59] directory and is in the format:

XYxxnnnn.IF

where:

xx	Plot index number.
nnnn	File ID as defined in the plot definition.

For example, the file **XY151234.IF** corresponds to the plot definition with an index number of 15 and a file ID of 1234.

The characteristics of an MFC data source plot are set up during plot definition. Specifically, plot definition identifies:

- Data source as MFC.
- File ID.
- MFP module address.
- Trigger tag.
- Initial x-axis high limit and low limit.
- Border color.
- Reference line colors.
- Plot legend.

Refer to the discussion on XY plot definition in the **Configuration** instruction for an explanation of data source and for the procedures to define a plot (Table 1-2 lists instruction numbers). Also, the instruction explains XY plot display configuration requirements.

Plot Display

An XY plot display can contain up to three MFC data source plots. Each plot presents the data from a single data file. The data can be plotted as a smooth curve or in steps on an x,y graph. This is determined by the data file and not the console. A maximum of 480 samples can be plotted for a single plot.

The update of a plot depends on the program collecting the data. When the trigger tag of a plot goes from zero to some file size, the module sends a data file to the console. The trigger tag is an ANALOG type tag that references an analog exception reporting block in a PCU module.

A new data file from the module overwrites any existing data file. The new data file is read to update the display. If a data file for a plot has not been received, the display remains blank and the following message appears until the data becomes available:

No data from the module for plot index n

The data file contains parameters that set the high scale and low scale limits for a plot. Data values are plotted proportionally between the high and low scale limits. Any values that fall outside these limits are not plotted.

The module can mark a data point as being in alarm. The display shows an area on the plot line in red to indicate when a point was in alarm.

A single plot element can contain up to five reference lines. The lines can be drawn in either a vertical or horizontal direction. The data file enables the reference lines. The plot definition sets the color of each line.

Plot Attributes

The attributes that appear for an XY plot and where they appear on the display are determined during display creation. The values come from a data file. During display creation, the plot display can be designed to include the following information.

Description	The description is the text entered as the plot description during its definition.
Plot Legend	A plot legend can be incorporated into a display during its creation if desired. The plot definition defines the text of the legend.
Reference Line Value	Up to ten reference line values can be displayed. A reference line value field can show either the x-axis value or y-axis value for a reference line. Up to five reference lines are possible for a plot.

Update Mode	The initial update mode is the update mode set during plot definition. The continuous curve (CC) mode is recommended for MFC data source plots.
X-Axis and Y-Axis Scale Limits	The initial x-axis and y-axis scale limits are set during plot definition. The data file contains values that override these initial values.
X-Axis and Y-Axis Last Value	The x-axis and y-axis last value is the last value retrieved from the data file for either or both the x-axis and y-axis.

Plot Control

Using XY plot control, a plot display can be switched between different data files while the display is on the screen. This eliminates the need to have several dedicated displays for a set of plots if desired. The control features are set on a per plot basis.

Initially, a plot element of a display shows the data from a specific plot definition. A parameter defined during display creation selects the plot definition used by the element initially. At any time after calling an XY plot display, another active MFC data source plot definition (data file) can be called to the display to replace the current data file. Some restrictions apply, however, when selecting a different plot definition.

Selecting a different plot definition (data file) affects only one plot element at a time. The change is only temporary and after exiting, the element resets to the plot definition selected for it during display creation.

To call another data file from the current XY plot display:

1. Select one of the plot elements. Press the key identified by a selector character or use a touch point. An *X TARGT MODE* field appears. The *X* portion indicates the currently selected and active plot for control (e.g., *A*, *B*, or *C*). The control prompt location depends on display creation.
2. Enter the index number of an active MFC data source plot. A valid entry is from 1 to 80.
3. Press **ENTER**.

A plot must be active to call it to the display. Up to ten MFC data source plots can be active at one time. If the plot being called is not active, the following message appears.

Plot must be ACTIVE in order to continue

A plot must be of MFC data source type to call it to the display. If not, the following message appears.

Plot is not of MFC Data Source Type

Up to six plot elements can be on display at one time, but only three in a single window. If the entered plot index is already displaying in the current window, the following message appears.

Plot already on display

If the same display is called in a different window, changing plot index is not permitted. If an attempt is made to change the index, the following message appears.

Same display on CRT n cannot change plot

SECTION 16 - OPERATOR CONFIGURABLE DISPLAYS

INTRODUCTION

This section explains the operator configurable displays function. This function allows creating displays as needed from menu selections on the console. It gives the ability to create a group display without having to use the console configuration tools (WLDG). An operator configurable display is normally a temporary display and can be modified or deleted at any time. If desired, an operator configurable display can be made permanent, but then it can no longer be modified using the operator configurable displays function. Up to 25 displays can be created.

NOTE: The parameters controlling operator configurable displays operation can be seen by sequencing through the pages of the *Operator Displays' Faceplates* option.

OPERATOR DISPLAYS

The *Operator Displays' Faceplates* configuration procedure explained in the **Configuration** instruction selects the symbol files used to create operator configurable displays (Table 1-2 lists instruction numbers). The default operator configurable displays configuration uses standard control, data acquisition, alarm summary, and trend elements to create group displays. These elements are provided with the console. The default symbols can be changed to user-created symbols if desired.

Figure 16-1 is an example display that contains STATION, ANALOG, DIGITAL, RCM, and MSDD tag elements; a trend element; and an alarm summary element. Figure 16-2 shows the operator configurable displays setup for this example display.

Control and Data Acquisition Elements

Three types of variables fall under the control and data acquisition element category: Analog, digital, and text string. A control element added to an operator configurable display allows controlling and presenting information for the following types of tags:

DD	RMCB
MSDD	RMSC
RCM	STATION

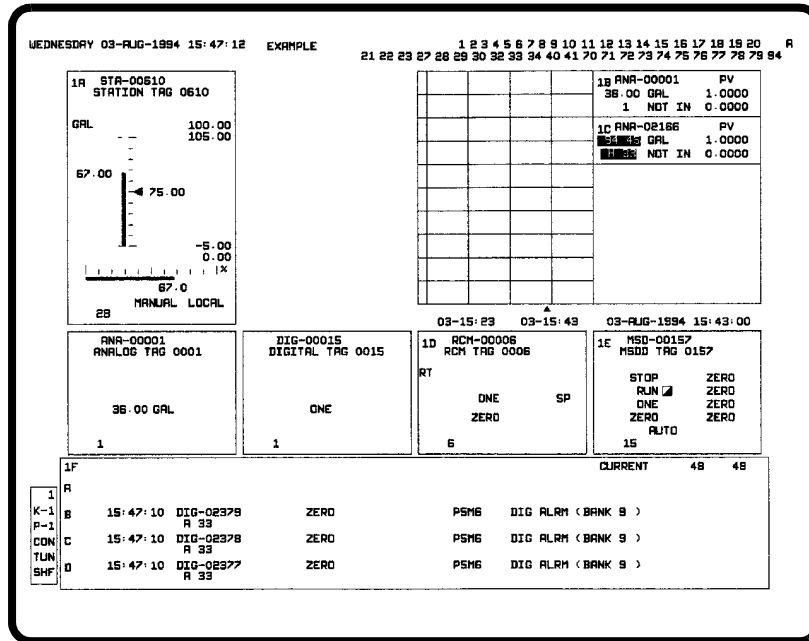

TPS0043B

Figure 16-1. Example Operator Configurable Display

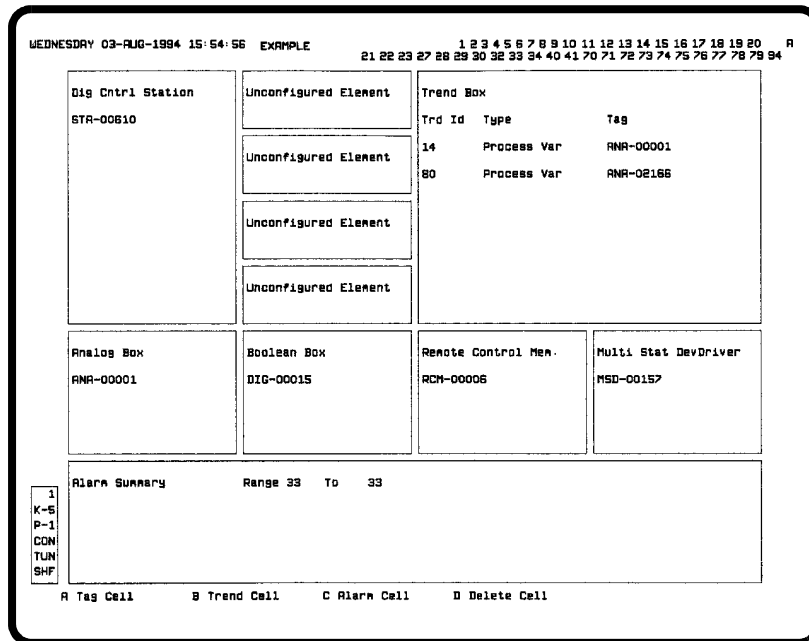

TPS0042B

Figure 16-2. Example Display Setup

A data acquisition element added to a display allows viewing a process variable reported for one of the following types of tags:

ANALOG	DANG
DAANALG	DIGITAL
DADIG	INTANG
DADIGTL	INTDIG

A TEXTSTR element added to a display allows viewing a text string sent to the console from a PCU module and entering a text string in response to the question or prompt introduced by the module. Refer to [Section 9](#) and [Section 10](#) for a description of the information presented and the control actions that can be performed from control and data acquisition elements.

Trend Element

A trend element as part of the display allows viewing distributed trend data. Several sizes are available. An operator configurable display references a trend definition to acquire data. Refer to **TREND CONTROL** in Section 14 for a description of the operations that can be performed from a trend element.

Alarm Summary Element

An alarm summary element provides all normal summary capabilities. Several sizes are available. The format used for each alarm line entry is selected during *Operator Displays' Faceplates* configuration. Refer to **ALARM SUMMARY** in Section 12 for a description of the operations that can be performed from an alarm summary element.

Creating a Display

An operator configurable display can be created in any format desired, but is limited to certain types of elements. Two pages are used to create a display: Directory and edit. The procedures to create a display include:

- Defining a display name.
- Entering display elements.
- Saving the display.

After being created, a display can be edited or deleted at any time.

Use the *Operator Configurable Displays* option to create temporary group displays. The directory page is the initial page when the function is first selected (Figure 16-3). To choose the

option, first press **GENL FCTNS MENU**, then select the following menu items in the sequence shown.

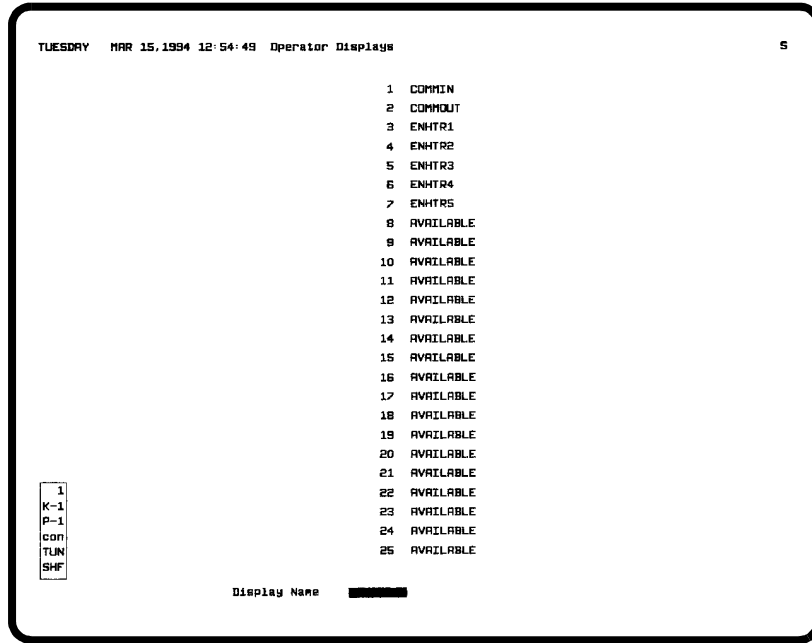
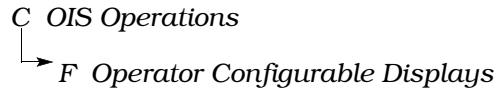

TPS0040B

Figure 16-3. Operator Configurable Displays - Directory Page

DIRECTORY PAGE

The directory page provides two functions. The first is a directory listing of both configured and unconfigured displays. The second is to call a configured display to either edit or delete it or to call a blank page to create a new display.

A display name appears for each configured display. This name or its index number is used to call a display for editing or deletion. An *AVAILABLE* appears for each unconfigured display. After creating then saving a display, its name replaces one of the *AVAILABLE* fields.

To modify or delete an **existing** display:

1. Enter the name or index number of the display in the *Display Name* field.
2. Press **ENTER**. The next page that appears shows the configuration for the display. Refer to Figure 16-2 for an example.

To create a *new* display:

1. Enter a name that does not already exist in the *Display Name* field. The name entered should be meaningful since this name also appears as the display title. Additionally, the name is used to call the configured display.
2. Press **ENTER**. If the display does not exist, an unconfigured page appears (Figure 16-4).

The following message appears if the name entered is of a display that cannot be modified with this function:

Display Requested Not Operator Configurable

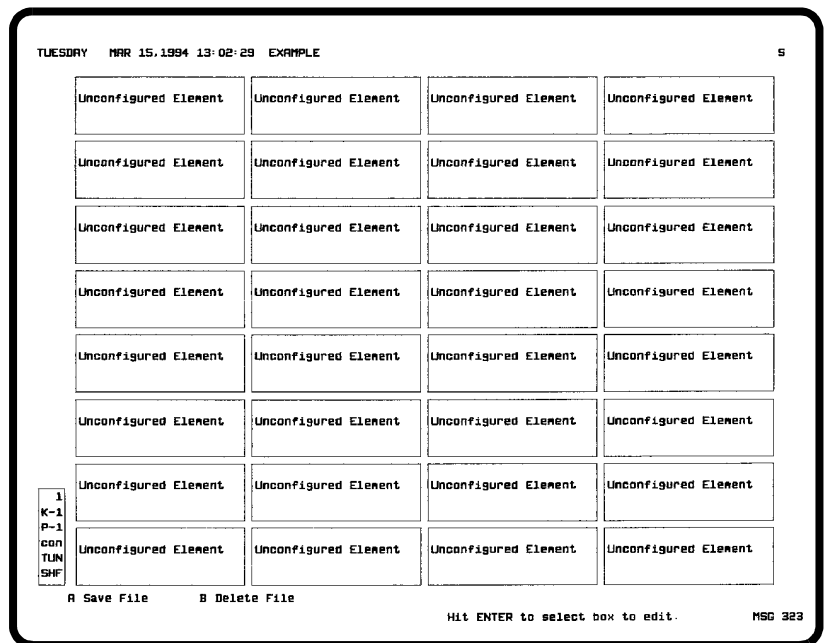

Figure 16-4. Operator Configurable Displays - Edit Page

EDIT PAGE

The actual display creation or editing is performed on the edit page. For an unconfigured display, the page appears as shown in Figure 16-4. The page contains 32 *Unconfigured Element* boxes. Each unconfigured box identifies an area of the display that is available for placing a tag, trend, or alarm summary element.

Each element that can be incorporated into a display consumes a specific number of unconfigured boxes. The number of elements that can be defined in a single display depends on the number of boxes each element type consumes. For example, the *Dig Cntrl Station* element in Figure 16-2 consumes four

vertical *Unconfigured Element* boxes, the *Alarm Summary* element consumes a total of eight boxes. Most element types come in varying sizes to help maximize the available space.

SELECTING A BOX

A cursor identified as a highlighted outline (cyan) appears and can be moved on this page. Initially, the cursor appears at the upper left corner.

When creating a display, the cursor allows positioning elements on the page by moving to, then selecting a specific box. It also allows redefining or deleting an existing element by positioning the cursor on the element. Options are presented at the bottom of the display to enable defining or deleting an element after making a box selection.

To select a box to edit:

1. Move to an *Unconfigured Element* box or any configured element box if editing or deleting that element. The selection determines where to begin drawing an element, not its actual size.
2. When the cursor is on the desired box, press **ENTER** to select it.

DEFINING AN ELEMENT

The options presented when defining an element depend on whether the selected box is an *Unconfigured Element* or a previously defined element. The type and specific symbol to insert is automatically selected based on user inputs. Figure 16-2 shows the options.

A configured box does not have to be deleted to redefine it. The function allows selecting a configured box, then redefining its attributes.

The following options are available after selecting a configured box. The *Delete Cell* option is not available if the box is an *Unconfigured Element* box.

Tag Cell Press **A** to select the *Tag Cell* option. A *Tag Name or Index* field appears. This is used to put a tag element into the display. The type of tag being entered determines the next prompts that appear.

Trend Cell Press **B** to select the *Trend Cell* option. This is used to put a trend element into the display. Each trend that is to appear in the trend element can be configured by entering either a trend index number or a tag name or index number, then selecting an element size.

- Alarm Cell** Press **[C]** to select the *Alarm Cell* option. This puts an alarm summary element into the display. Additional options select the element size and alarm groups that are to appear in the summary.
- Delete Cell** Press **[D]** to select the *Delete Cell* option. This option deletes an element making the area available as *Unconfigured Element* boxes.

Each option is explained in more detail in the sections that follow.

NOTE: The *Save File* and *Delete File* options are available initially and after completely defining an element.

SAVING TO A FILE

After a display is completely defined, it must be saved by using the *Save File* option. During a save, a configuration file (**CF**) and a display file (**DU**) are created. Press **[A]** when editing is complete to save a configured display. The following message appears:

Display being constructed, Please Wait

Do **not** press any keys while the display is being constructed. If the operator configurable displays function is exited while the display file is being constructed, the changes are not saved. When complete, the system returns to the directory page.

Press **[ESC]** before saving to abandon any edits. If changes were made to an existing file and the changes were not saved, the following message appears:

Change Made. <ENTER> to save, <ESCAPE> to abandon

Press **[ENTER]** to save the changes and exit. Press **[ESC]** to continue to exit without saving.

DELETING A DISPLAY FILE

The *Delete File* option clears the current operator configurable display. Both the configuration file and display file are deleted. This also removes the display name from the directory list and replaces it with an *AVAILABLE*. Press **[B]** to delete the current display.

It is suggested that any displays no longer in use be deleted. This frees up hard disk space for use by other console functions.

BOX OVERLAP

The size of each element being defined must be considered when creating a display. An overlap may occur when attempting to define an element and the chosen size of that element expands over part or all of another already defined element. The console will not draw one element over another.

The console looks for an open spot to place an element before indicating an overlap. Initially, the search is down and to the right. The search will continue up and to the left if an existing element is encountered. The search is always from the cursor location. The cursor determines the starting point for drawing an element and the console cannot reposition this cursor. If an open spot cannot be found, the following message appears:

Box Overlap: <ENTER> - accept, <ESC> - reject

A red outline is also drawn to show where the overlap occurred. The outline is in the size of the element being entered and causing the overlap error. Any configured elements that fall within this red outline are the overlapped elements.

Two choices are available to correct the error. The element being defined must be sized or positioned to eliminate the overlap. Or, the overlapped elements can be overwritten by the overlapping element, then the deleted elements redefined in a new position. The *Box Overlap* message enables these choices.

Press **ENTER** with the message on the screen to **accept** the overlap and overwrite any overlapped elements. The screen updates with the new element after accepting. The overlapped elements no longer appear. Press **ESC** to **clear** the overlap without overwriting. If rejected, the screen restores to its previous state.

Defining a Control or Data Acquisition Element

An operator configurable display can include a control or data acquisition element. A tag name or index number must be known to define this type of element. In some cases, the function requires selecting an element size.

A symbol file is automatically inserted based on tag type and size selection. The symbol must reside on the hard disk as an

assembled symbol file (**DL**), however. Table 16-1 lists the default source files used for each type of tag.

Table 16-1. Control or Data Acquisition Element Source Files

File Name (.DT)	Tag
ANALOG1	ANALOG, INTANG, DAANALG
ANCBOOL1	DIGITAL, INTDIG, DADIGTL (annunciator)
ANCREAL1	ANALOG, INTANG, DAANALG (annunciator)
ANLGCTL1	ANALOG (control)
ANLGHF1	ANALOG, INTANG, DAANALG (half size)
BOOLCTL1	DIGITAL (control)
BOOLEAN1	DIGITAL, INTDIG, DADIGTL
BOOLHF1	DIGITAL, INTDIG, DADIGTL (half size)
DADIG1	DADIG (full size)
DCSFULL2	STATION
DCSHALF1	STATION (half size)
DEVDR1	DD
DNGFULL1	DANG (full size)
DNGHALF1	DANG (half size)
MSDEVDR1	MSDD
RCM1	RCM
RMSC1	RMSC
RMCB1	RMCB
TEXTSTR1	TEXTSTR

Figures 16-5 and 16-6 show each tag type and the element sizes available.

To define an element:

1. Select an *Unconfigured Element* (or configured) box, then press **ENTER**. A bottom line menu appears.
2. Press **A** to select the *Tag Cell* option. A *Tag Name or Index* field appears.
3. Enter either a tag name or an index number, then press **ENTER**. The tag type is checked and if not allowed for this function, an error message will appear.

At this point, one of two things happens.

- If defining a DADIG, DD, MSDD, RCM, RMCB, RMSC, or TEXTSTR tag element, a configured box containing an element type descriptor and tag descriptor is drawn (Figures 16-5 and 16-6).

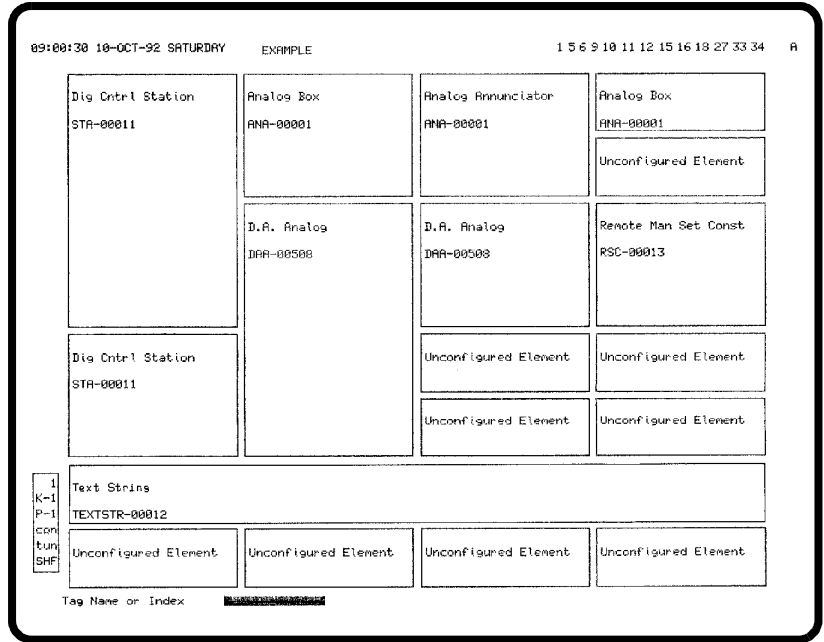

TPS0044B

Figure 16-5. Tag Elements (Page 1)

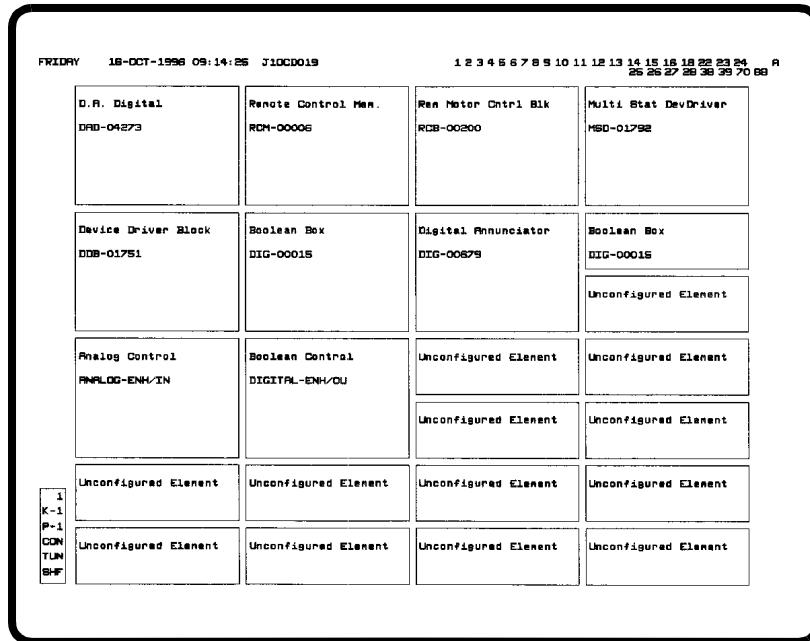

TPS0774B

Figure 16-6. Tag Elements (Page 2)

- Additional options are presented to indicate additional information is needed. This will occur for all remaining tag types.

4. Select the element type and size by performing one of the following procedures.

For an **ANALOG**, **INTANG**, or **DAANALG** tag the options are *A Analog*, *B Annunciator* and *C Control Box*. Both types can be seen in Figure 16-5.

Press **A** to select a regular analog element. Select its size by pressing **A** for *Full* size or **B** for *Half* size.

Press **B** to select an annunciator type analog element.

Press **C** to select an analog control element.

For a **DIGITAL**, **INTDIG**, or **DADIGTL** tag the options are *A Boolean*, *B Annunciator* and *C Control Box*. All types can be seen in Figure 16-6.

Press **A** to select a regular digital (boolean) element. Select its size by pressing either **A** for *Full* size or **B** for *Half* size.

Press **B** to select an annunciator type digital element.

Press **C** to select a digital control element.

For a **DANG** or **STATION** tag the options are *A Full* and *B Half*. Both types can be seen in Figure 16-5.

Press **A** for *Full*.

Press **B** for *Half*.

After making all selections for the element, a configured box containing an element type descriptor and tag descriptor is drawn.

5. Continue to configure all control or data acquisition elements that are to appear in the final display by repeating the previous steps. If only control and data acquisition elements are to appear in this display, continue with the next step. If trend and alarm summary elements are to be added, skip the next step and follow the procedures given in **Defining a Trend Element** and **Defining an Alarm Summary Element** in this section.

NOTE: If adding trend or alarm summary elements to this display, define those elements **before** saving the display.

6. Press **A** to select *Save File* to create the final display file. Press **ESC** to exit without saving or to abandon any edits.

Defining a Trend Element

An operator configurable display can include a trend element. The name or index number of a tag being trended or a trend index number must be known to define this type of element. The function also requires selecting an element size.

A symbol file is automatically inserted based on the type of trended variable (i.e., control output, set point, ratio index, etc.) and size selection. The symbol must reside on the hard disk as an assembled symbol file (**DL**), however. Table 16-2 lists the default source files used for each type of trended variable.

Table 16-2. Trend Element Source Files

File Name (.DT)	Trend ¹
TRNDCOFL	Control output (full)
TRNDCOHF	Control output (half)
TRNDDGFL	Digital (full)
TRNDDGHF	Digital (half)
TRNDPVFL	Process variable (full)
TRNDPVHF	Process variable (half)
TRNDRIFL	Ratio index (full)
TRNDRIHF	Ratio index (half)
TRNDSPFL	Set point (full)
TRNDSPHF	Set point (half)

NOTE:

1. The full and half do not refer to the element size, but rather the attributes that appear for each trend. When a half source file is used, the tag descriptor does not appear for the trend.

Colors for trends are set during *Operator Displays' Faceplates* configuration. The overall display resolution for a trend element is the maximum collection resolution of all trends included in the element when it contains standard trends only. The display resolution is either the least common multiple of all trend collection resolutions or the display resolution set in the definition of an enhanced trend if it is a valid multiple of all trends included in the element.

Figure 16-7 shows some available trend element sizes. The figure uses the 1/2 screen, 1/2 by 1/2 and 1/4 by 1/2 sizes.

To define a trend element:

1. Select an *Unconfigured Element* (or configured) box, then press **ENTER**. A bottom line menu appears.
2. Select the *Trend Cell* option. A list of size options then appears at the bottom of the window.

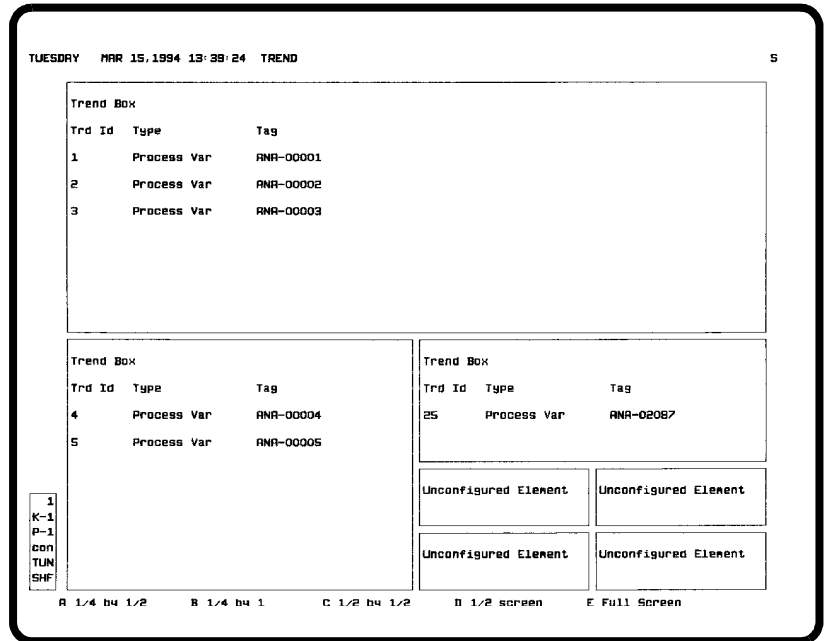

TPS0045B

Figure 16-7. Trend Elements

- A 1/4 by 1/2
- B 1/4 by 1
- C 1/2 by 1/2
- D 1/2 screen
- E Full Screen

3. Select the desired size then choose the bottom line:

- A By Tag Name
- B By Trend Index

4. A trend can be defined by entering a trend index number or by entering a tag name or index number.

Tag Name To select a trend using the *By Tag Name* option:

- a. Press **A**. A *Tag Name or Index* field appears.
- b. Enter a tag name or index number. The entry must be of a tag that is defined in a trend definition.
- c. The control output, process variable, ratio index, and set point of a STATION tag can be trended. A subtype selection is required when trending a STATION tag since there may be a trend defined for each tag variable. The spe-

cific variable being trended is identified by a subtype entered during trend definition. The options are:

- A *Process variable*
- B *Set point*
- C *Ratio index*
- D *Control output*

Choose one of the options. If a trend definition with the selected type of variable cannot be found, an error message appears.

d. If the trend element size selected previously was *1/2 by 1/2* or larger, up to five trends can appear in the element. To enter additional trends, press **TAB**. Continue to make entries in these fields until all desired trends are entered.

Trend Index To select a trend using the *By Trend Index* option:

- a. Press **B**. A *Trend Index* field appears.
- b. Enter a trend index number. Unlike the tag index method, this is the only information required. All information required by the function is available in the trend definition.
- c. If the trend element size selected previously was *1/2 by 1/2* or larger, up to five trends can appear in that element. To enter additional trends, press **TAB**. Continue to make entries in these fields until all desired trends are entered.

5. Press **ENTER**. A configured element box containing an element type descriptor and the following information for each trend will be drawn (Figure 16-5):

Trd Id - trend descriptor.

Type - process variable, set point, control output, ratio index, or digital value descriptor.

Tag - tag descriptor.

6. Continue to configure all trend elements that are to appear in the final display by repeating the previous steps. If only trend elements are to appear in this display, continue with the next step. If control, data acquisition, and alarm summary elements are to be added, skip the next step and follow the procedures given in ***Defining a Control or Data Acquisition Element*** and ***Defining an Alarm Summary Element*** in this section.

NOTE: If adding control, data acquisition, or alarm summary elements to this display, define those elements **before** saving the display.

7. Press **A** to select *Save File* to create the final display file. Press **ESC** to exit without saving or to abandon any edits.

Defining an Alarm Summary Element

An operator configurable display can include an alarm summary element. The alarm groups that are to appear in an alarm summary element must be identified and an element size selected to define this type of element.

The alarm summary line format chosen during *Operator Displays' Faceplates* configuration determines the size options. The maximum number of alarm entries that can appear in a single alarm summary is either 16 or 24 depending on the line format being used.

An alarm summary line format defines:

Attribute colors - color for each attribute of an entry.

Line attributes - specific data items that appear and their location in an entry.

Line option - number of display lines reserved for each entry in the summary.

Refer to the discussion on alarm summary configuration in the **Configuration** instruction for further explanation of alarm summary line formats (Table 1-2 lists instruction numbers).

Figure 16-8 shows some available alarm summary element sizes. The figure uses the *1/2 screen*, *1/4 screen* and *1/8 screen* sizes.

To define an alarm summary element:

1. Select an *Unconfigured Element* (or configured) box, then press **ENTER**. A bottom line menu appears.
2. Press **C** to select the *Alarm Cell* option. A list of size options then appears at the bottom of the window. The size options that are available for an alarm summary element depend on the line format being used. The following paragraphs show the options available based on the line option used in the selected line format.

Line option 0:

- A *1/8 screen*
- B *1/4 screen*
- C *1/2 screen*
- D *Full Screen*

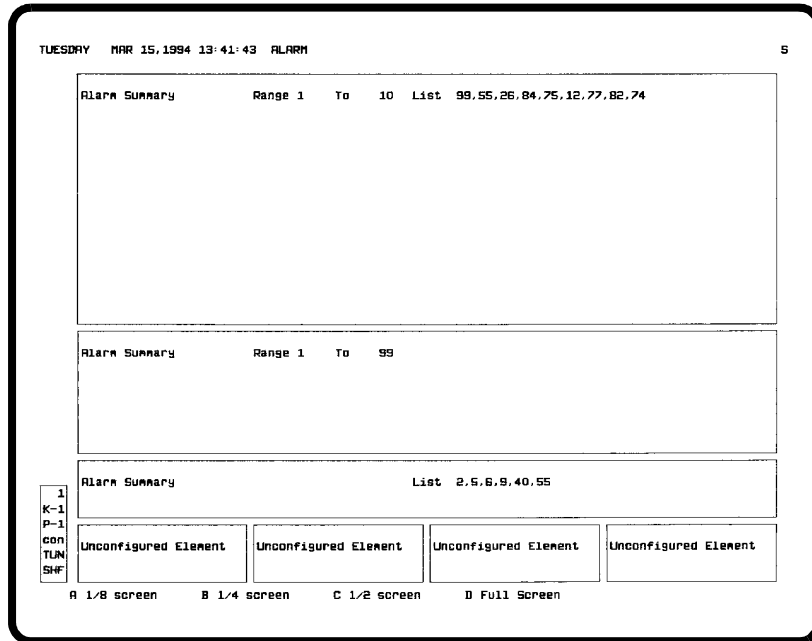

Figure 16-8. Alarm Summary Elements

Line option 1:

- A 1/4 screen
- B 1/2 screen
- C Full Screen

Line option 2:

- A 1/8 screen
- B 1/4 screen
- C 1/2 screen
- D Full Screen

After reaching the maximum number of alarm entries a display can present, the *C Alarm Cell* option is removed as a cell type option. No other alarm summaries can be defined in the display. When using line option two with a 4.5 millimeter character height, only a full size alarm summary can be created.

Table 16-3 gives a breakdown of the number of line entries each element size presents based on its line option.

Table 16-3. Alarm Summary Entries

Line Option	Number of Alarm Entries			
	1/8	1/4	1/2	Full
0	2	4	8	16
1	N/A	2	4	8
2	4	8	16	24

3. Press either **A**, **B**, **C**, or **D** to select the desired size. The following fields appear:

Range ___ *To* ___ *List* ___

4. The input fields allow entering an alarm group range, alarm group list, or both to select which tags are to appear in the summary based on alarm group assignment. Enter the alarm groups that are to appear in the summary.

Range The *Range* and *To* fields determine which tags appear in a summary by specifying an alarm group range. The range can include all alarm groups, which is a range of 1 to S. The range can also limit the number of groups. For example, enter **2** and **45** to show only those alarms for tags in alarm groups two through 45.

List The *List* field allows specifying up to ten alarm groups. Press **TAB** after the initial entry to specify up to nine additional groups.

The range and list options can be used together or separately if desired.

5. Press **ENTER** after all inputs have been made. A configured element box containing an element type descriptor and list of alarm groups will be drawn (Figure 16-8).

6. Continue to configure all alarm summary elements that are to appear in the final display by repeating the previous steps. If only alarm summary elements are to appear in this display, continue with the next step. If control, data acquisition, and trend elements are to be added, skip the next step and follow the procedures given in *Defining a Control or Data Acquisition Element*, and *Defining a Trend Element* in this section.

NOTE: If adding control, data acquisition, or trend elements to this display, define those elements *before* saving the display.

7. Press **A** to select *Save File* to create the final display file. Press **ESC** to exit without saving or to abandon any edits.

Making an Operator Configurable Display Permanent

The configuration files for each operator configurable display occupy 13 records on the disk along with the display file. It is recommended that an operator configurable display not be created for use as a permanent display as it consumes a considerable amount of disk space. An operator configurable display, however, can be made permanent by deleting its associated configuration file (**CF**) from the [DATA.USN53] directory. The display can then no longer be modified by using the operator configurable displays function.

Making Room for Additional Displays

When the 25 display limit is reached for operator configurable displays, perform the following to make room for additional displays without having to delete a display:

1. Save all or some of the configuration files (**CF**) located in the [DATA.USN53] directory to floppy disk.
2. Delete the **CF** files saved to floppy disk from the [DATA.USN53] directory.

Deleting the **CF** file for a display does not affect its **DU** counterpart. Since the **DU** file still exists on the hard disk the display can be called as normal. To modify a display originally created with the operator configurable displays function, its corresponding **CF** file must be copied back to the [DATA.USN53] directory. Make sure there are no more than 25 **CF** files in the directory.

SECTION 17 - OPERATOR ACTIONS AND INFORMATION

INTRODUCTION

This section explains the operator request for action page and the operator information page. These pages identify both current, successful console operations and operations that require some additional action to continue.

NOTE: Currently, the majority of information presented in these pages relates to archival storage and retrieval.

OPERATOR ACTION REQUESTS

The operator request for action page is used to inform of some action required to continue processing for a certain operation. The action indicated identifies the attempted action and after being selected provides options to respond to the action request.

An *A* appears at the title line to alert the operator that at least one action request is outstanding. The *A* blinks if any request has not been acknowledged. The indicator remains until all actions listed on the operator requests for action page have been cleared.

When the *A* appears, perform the following steps to process a request for action:

1. Call the operator requests for action page.
2. Acknowledge the request.
3. Respond to the request.

Calling the Operator Action Requests Page

Use the *Operator Action Requests* option to process all new and outstanding action requests. Figure 17-1 shows the display used. To call this page, first press **GENL FCTNS MENU**, then select the following menu items in the sequence shown.

C *OIS Operations*
└─→ B *Operator Action Requests*

Select *Operations* then *Action* from the menu bar to call a page containing a half-sized operator request for action element and a half-sized operator information element. The same information and functions available with the full-sized operator

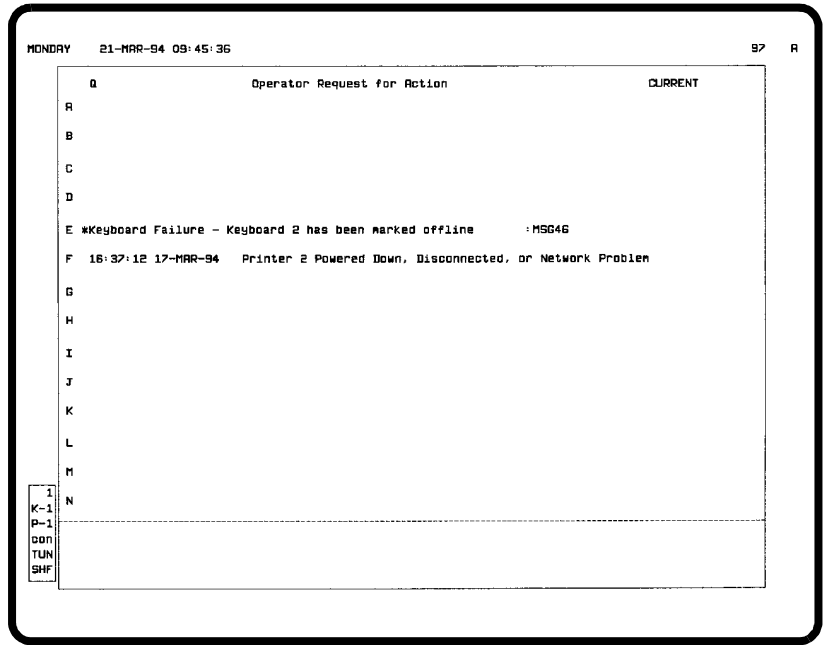

TPS0090B

Figure 17-1. Operator Action Request Page

request for action page can be seen and performed with the half-sized element.

The parts of the display are:

Action Item Selectors

Down the left side are action item selectors. The selectors are used to enable a request on which to act. They cannot be accessed until the page is frozen (enabled using the display selector). Initially, these selectors appear in cyan when the page is not frozen and change to red after display select.

Display Selector

A red Q at the upper left corner is the display selector. While the page is on the screen, additional action requests may appear. The selector both enables the page for operation and freezes it to prevent additional entries from appearing in the list. If any additional action requests occur during the time the page is frozen, they appear in the list as soon as the page is disabled (unfrozen).

Page Indicator

The operator request for action page maintains a list of all outstanding actions. A page indicator appears at the upper right corner to show whether the displayed actions are the most current or if they are older requests. The indication will be either *CURRENT* or *PAGING*. *CURRENT* appears when on the first page of actions. *PAGING* appears after the next or subsequent pages are on the screen.

Unacknowledged Indicator

A yellow asterisk (*) appears next to an action item and blinks if the request has not been acknowledged. The asterisk is removed after selecting an action item.

When on the *CURRENT* page, the top four lines are reserved for new requests that occur after the page has been called. As these lines fill, the page scrolls the oldest action item off the page and displays the ten most recent messages.

Processing an Action Request

The purpose of an action request is to identify a step or procedure that is required to continue with a certain operation. It is also, in some cases, used just to get an acknowledgment before performing an operation. For example, the need to install a new medium for archiving is identified with an action request. A prompt for approval to initialize a medium and a prompt to initiate a retry are also examples of action requests. Until a request is acknowledged then acted upon, the console cannot continue with an identified, attempted operation.

Example: An attempt is made to archive data to magnetic tape and the attempt was unsuccessful. The following message appears on the operator request for action page:

*TRYING TO ARCHIVE TO OPTICAL 'ALP1' 0003
VOLUME IS NOT INSTALLED*

After acknowledging the problem, the following message appears:

Press ENTER when volume is installed

To clear this action request, an optical disk medium must first be installed, then **ENTER** pressed. If the response to the action request was appropriate, then the archive to medium will begin. If not, another or the same action request will appear in the list.

Enabling the Action Requests Page

The operator request for action page must first be enabled to perform any acknowledgment or action request processing. After being enabled, the page freezes and no additional action requests will appear until the page is disabled (unfrozen).

Press **Q** to enable the page. The outline of the page highlights and the action selectors along the left edge change to red. The display selector (*Q*) disappears.

Press **ESC** at any time to disable the page. If any additional operator requests for action occur during the time the page is frozen, they appear in the list as soon as the page is disabled (unfrozen).

Paging Through Entries

The operator request for action function may have several pages of entries. The number of pages depends on the number of outstanding action items. Press **NEXT PAGE** or **PREV PAGE** after freezing the page to view additional pages. Press **HOME** to return to the *CURRENT* page.

Acknowledging a Request

The first step in processing a request is to acknowledge the request. After all action requests have been acknowledged, the title line indicator stops flashing. Two choices are available for acknowledging requests, either individually or an entire page. The unacknowledged indicator (*) for a request clears from the page after the request is acknowledged.

Press **PAGE ACK** with the request for action list enabled to acknowledge all requests on the current page. This can be performed if the requests have been viewed, but no action will be taken at this time.

To acknowledge and process a single action request, first enable the list then:

1. Select the action request to process by pressing the selector key for the request. The letter next to the request indicates the key to press. The selector letter changes to yellow to identify an action as being selected.

A response prompt appears at the bottom of the page that identifies the action to perform. In some cases, only an acknowledge, retry, or continue response is required to proceed. The type of response required to clear an action item depends on the type of request. Some examples are:

Press ENTER to acknowledge

- or -

Press ENTER to initialize magtape

Press **ESC** at any time to cancel. The request remains in the list as an outstanding action. The action selector for the request returns to its red color after pressing **ESC**

2. Take any necessary actions required to respond to the action request. For example, install a new medium if the message indicates the current medium is full.
3. Press the key indicated in the message. The action request then clears from the list.

- Press **ESC** to disable the page.

If the actions taken to clear a request were not sufficient to continue processing, the request will appear again as a new request in the list.

OPERATOR INFORMATION EVENTS

The operator information events function provides a chronological, running list of operations performed by the console. Use the *Operator Information Events* option to call the list. Figure 17-2 shows the page used. To choose the option, first press **GENL FCTNS MENU**, then select the following menu items in the sequence shown.

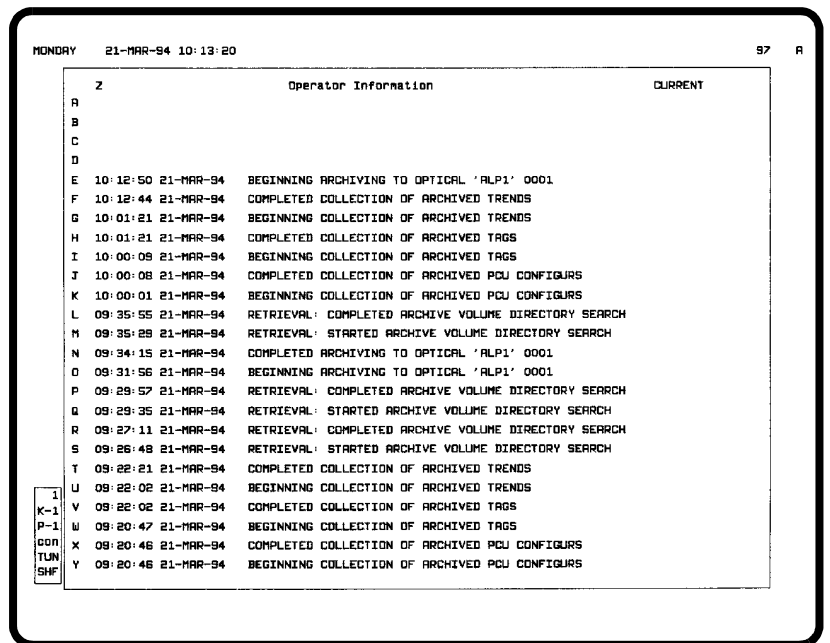
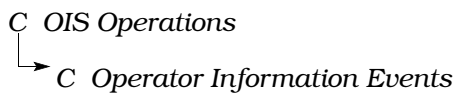

TPS0221B

Figure 17-2. Operator Information Events Page

Select *Operations* then *Action* from the menu bar to call a page containing a half-sized *Operator Request for Action* element and a half-sized *Operator Information* element. The same information and functions available with the full-sized *Operator Information Events* page can be seen and performed with the half-sized element.

The parts of the display are:

Event Selectors

Down the left side are selectors used to delete events. They cannot be accessed until the page is frozen. Initially, these

selectors appear in cyan when the page is not frozen and change to red after display select.

Display Selector A red Z at the upper left corner is the display selector. While the page is on the screen, additional information events may appear. The selector both enables the page for operation and freezes it to prevent additional entries from appearing in the list. If any additional information events occur during the time the page is frozen, they appear in the list as soon as the page is disabled (unfrozen).

Page Indicator A page indicator appears at the upper right corner of the page to show whether the displayed events are the most current or if they are older events. The indication will be either *CURRENT* or *PAGING*. *CURRENT* appears when on the first page. *PAGING* appears after the next or subsequent pages are on the screen.

When on the *CURRENT* page, the top four lines of the page are reserved for new events that come in after the page has been called. As these lines fill, the page scrolls the oldest event item off the page and displays the most recent messages.

Enabling the Information Events Page

The operator information events page must first be enabled to perform any operations. After being enabled, the page freezes and no additional information events will appear until the page is disabled (unfrozen).

Press **Z** to enable the page. The outline of the page highlights and the action selectors along the left edge change to red. The display selector (Z) disappears.

Press **ESC** at any time to disable the page. If any additional information events occurred during the time the page was frozen, they appear in the list as soon as the page is disabled (unfrozen).

Paging Through Entries

The operator information page may have several pages of entries. Press **NEXT PAGE** or **PREV PAGE** after freezing the page to view additional pages. Press **HOME** to return to the *CURRENT* page.

Deleting Entries

The only operation to perform from this page is to delete event entries. Two options are available for deleting entries, either individually or an entire page. In either case, the page must first be enabled.

Press **PAGE ACK** to delete all entries on the current page.

Press the key indicated by the letter next to an entry to delete the entry. The entry clears from the list as soon as the selector key is pressed.

SECTION 18 - LOGS

INTRODUCTION

The console provides the ability to record process related information. One method of recording the data is in a hard copy log. The other is digitally on a storage medium explained in [Section 19](#).

Data collection and printing of a log normally occurs at a set schedule or after a certain process event occurs. Completed logs can also be stored for later printing. An option to print the current data collected for a log prior to completion of a collection period and printing schedule is provided.

This section explains the procedures to initiate a printout of a log using the *Log by Name* function. It also explains the functions used to view and change the status for certain types of logs.

LOGGING

The logging functions provide automatic collection capabilities for recording data. Normally, a log begins its scheduled collection period after being configured then activated. Depending on configuration and the type of log, a log normally prints after it completes its collection period or at a specific time. There are three types of logs: System events, custom, and sequence of events (SOE).

System Event Log

The system event log continues to collect data after being activated. The information recorded in this type of log relates to console operations and process changes.

Events can be printed as they occur and can be saved to disk for scheduled periodic printing. Up to 1,000 events can be saved to disk. The printing and saving of events occurs continuously as long as the system event log remains active. The system event log is made active during configuration. A periodic printout occurs at intervals set during configuration. The system event log can be separated into an event log and operator actions log during configuration.

Refer to the discussion on system event log configuration in the **Configuration** instruction for more information and for the procedures to activate and deactivate event log collection and periodic printing (Table 1-2 lists instruction numbers).

Custom Logs

Custom configured logs begin their data collection at a schedule defined during configuration or when operator demanded. This type of log collects process related information such as analog values, digital states, and trend data. Calculations can also be performed in the log.

A custom log begins its collection period at a scheduled time and at time intervals, after a specific process event occurs, or as soon as it is activated. The collection period can be zero for snapshot values to over one month. Printing can also take place after the same type of occurrences or immediately after a log has completed its collection period. A log must be activated to begin any data collection and printing. A log can be made active as the last step during its creation or later by using the *Log Status* function.

For each custom log, up to nine most recently generated can be retained for later printing. This is set up during log configuration.

Refer to the discussion on custom log configuration in the **Configuration** instruction for further explanation of custom logs and for the procedures to set up a log (Table 1-2 lists instruction numbers).

SOE Logs

The console provides the ability to retrieve and print data collected by:

- Sequential events recorders (SER).
- Sequence of events log slave (FC 210) function blocks in multi-function processor (MFP) or multi-function controller (MFC) modules.
- INSEM01 Sequence of Events Modules.

The recorders are capable of collecting data for several different types of sequence of events (SOE) logs. These include standard, summary, pre-fault, post fault, and snapshot type logs. The SOE (FC 210) function block and SEM module can collect data for either a snapshot or summary log.

For each type except summary, data collection and printing is automatic after activating a log. A log can be made active as the last step during its creation or later by using the *Log Status* function.

The MFP or MFC module directing the recorder operation reads data from the recorder and notifies the console when it

has data to send. The SOE (FC 210) function block and SEM module also notify the console of data. After being notified, the console then collects the data, formats a log, and directs the log to one of its printers. This is only true, however, for log types other than summary.

For a summary log, the state of the RCM tag associated with the log must be changed to trigger data collection. This is the same for either a recorder, SOE (FC 210) function block, or SEM module. Refer to **Generating Sequence of Events Summary Logs** in this section for further explanation and for the procedures to initiate data collection for a summary log.

For each SOE log, up to nine most recently generated can be retained for later printing. This is set up during log configuration.

Refer to the discussion on sequence of events log configuration in the **Configuration** instruction for further explanation of SOE logs and for the procedures to set up a log (Table 1-2 lists instruction numbers).

PRINTING AND DISPLAYING LOGS

The system event, custom, and SOE logs can all be set up to automatically print after completing their data collection. A *Log by Name* option allows printing any of these logs again if a copy has been retained on the hard disk. It can also be used to print the initial log if a log does not implement the automatic print feature (i.e., demand print type).

A log may or may not be configured to retain a copy of previously generated logs. In the case of a custom or SOE log, the *Number of Retentions* configured for the log determines if and how many generations are to be retained. This must be set to at least one to save a copy of a log for later printing and viewing. A log is saved only after it completes its entire collection period.

For the system event log, the number of events that can be printed or displayed depends on the number of events being saved to disk. The *Total Number of Events/Actions Saved To Disk* field on the event log configuration page determines this number.

Access to the *Log by Name* function can be gained in two ways: By using the miscellaneous functions menu or by using the command line menu. Perform either of the following to access the function.

To access the *Log by Name* function from the miscellaneous menu:

1. Press **MISC MENU**.
2. Select *B Log by Name*.

To access the *Log by Name* function from the command line menu:

1. Press **COM'D LINE MENU**.
2. Select *E LOG/NAME*.

In either case, the following prompt appears:

Log Name/Index ___ Retention ___ Print/Display ___

An index number can only be entered to identify a custom log or the event log, not an SOE log or the operator actions log. Refer to the sections that follow for further explanation. For any log type, a printout occurs at the logical printer defined during log configuration.

Use the *Log Status* function to view a list of currently configured custom logs and SOE logs. This function also indicates and allows changing the status of a log.

Display Log Operations

When displaying a log, it appears in the same format as the printed version. Only previously completed SOE and custom logs can be displayed. For display purposes, the system event log is not separated into an event log and an operator actions log. The event log can display in either a real-time mode or a snapshot mode. Search criteria can be defined, however, to select the type of data to display for the system events log. The search criteria only affects the real-time mode event log.

The window supports a maximum width of 300 characters. When the entire log contents cannot be displayed, the presentation can be repositioned. Press the double arrow keys or single arrow keys in the cursor and trend control block keyboard section to change the display presentation. Each press of a double arrow key moves the presentation $\frac{1}{4}$ -screen. The number of horizontal columns or vertical rows each press of a single arrow key is to shift the presentation can be defined. Press **NEXT PAGE** or **PREV PAGE** to also change the presentation.

To define the single arrow keys:

1. Select the *A Define Single ARROW Key* option.

2. Enter a number from 1 to 18. The default is 10.
3. Press **ENTER**.

When moving the presentation, the end of the log is identified with:

End of File

Since the same data appears in a display log as in the printed log, the order in which entries appear is the same as in the printed version.

The initial information displayed for a log is the same as the first page of the printed log (i.e., oldest information). Press **NEXT PAGE** to view newer data. Continue to press **NEXT PAGE** until the *End of File* appears to view the most recent entry in the log.

The display log function provides additional methods for moving the presentation for a displayed system events log. Refer to **CALLING IN SNAPSHOT MODE** in this section for an explanation of these additional methods.

Custom Configured Logs

For custom logs, the *Log by Name* function gives the ability to:

- Demand a printout of a retained log.
- Initiate a print for a log having a demand print type.
- Print the data currently collected for a log before it has completed its collection period.
- Display the contents of a custom log retained on the hard disk.

Custom log retentions are saved in individual files for each configured log. The file name identifies the log and retention of that log. The file name format is **LOGnnnn.Ln**. For example, the log file **LOG0012.LO** identifies custom log index number 12 and retention one. The most recently completed log is retention number one (e.g., **LO**). The retention number increases to correspond to chronologically older retentions with a maximum of nine (e.g., **L8**). The oldest saved copies are removed as new ones are created.

A printout automatically occurs for all logs that have either time, event, or collect print types. A log that has a demand print type requires using the *Log by Name* option to get the initial hard copy printout.

A printout of data already collected by an active log can be demanded at any time during the collection period. The printout contains only the data that has already been collected up to the current time and date. The log resumes with its normal scheduled collection after processing any demanded print.

To print or display a custom log:

1. After selecting the *Log by Name* option, the following prompt appears:

Log Name/Index ___ *Retention* ___ *Print/Display* ___

Key in a name or index number of a log in the *Log Name/Index* field. Use the log status function to find the name or index number of a custom log. Refer to **LOG STATUS** in this section for the procedures.

The name for a log is defined during its configuration. When entering a name, it must be completely spelled out. An index number can range from 1 to 300. The number is the log number assigned during configuration.

2. Enter a number from 0 to 9 in the *Retention* field to determine which log to print or display. Use 0 to print the current data collected for the log or if the log has a demand print type. The log must be active to obtain the current data. Use 1 to print the most recently saved copy or any number from 2 to 9 for older saved copies.
3. Enter either **PRINT** or **DISPLAY** in the *Print/Display* field.
4. Press **ENTER** to initiate the request. A printout occurs at the printer designated in the log configuration.

Refer to **Display Log Operations** in this section for information on how to move the display presentation.

Generating Sequence of Events Summary Logs

There are several different types of SOE logs. The standard, pre-fault, post fault, and snapshot SOE logs are all automatically generated after being setup. Generation of an SOE summary log, however, must be operator initiated.

An RCM tag allows the automatic collection and generation of a log. It also allows the operator to manually initiate data collection if the SOE log is set up as a summary log. An RCM element must exist for a summary log and be part of either a user-created display or an operator configurable display for the operator to initiate collection for the log. The tag used in the element is the tag that references the SOE function block

(FC 99 or FC 210) in an MFP or MFC module or fixed block 5000 or 5001 in an SEM module.

To generate an SOE summary log:

1. Call the display that contains the RCM element for the report to generate.
2. Select the RCM element for control.
3. Set the RCM tag to its one state. Refer to **RCM CONTROL** in Section 9 for the procedures.

NOTE: If using a multi-function controller module having firmware revision below F.0, set the target state to zero. The state changes identified in the following explanation should be reversed.

The RCM tag changing to show a one state indicates a response from the module. If the RCM tag remains in its zero state while the *TARGET:* is a *ONE*, check the module configuration. When the module completes the summary report and all data is sent to the console, the RCM tag returns to its zero state. A summary report is in progress while the RCM tag remains in its one state.

Data collection ends for a report after the age time set in the module elapses. The time in the age specification of an SOE log function block sets this age time. It determines when the RCM tag goes back to the zero state and how much data is expected from the recorder or function block for a summary report. The longer the age time, the more data the module handles. The log does not print until the module sets the RCM tag back to its zero state. Therefore, the longer the age time, the longer the wait for data.

The SOE log function block only responds to a control command initiated from the console (or some other host) to initiate data collection. This block cannot be directly changed to trigger data collection. After transferring data, the function block clears itself to allow another summary report request.

When a summary report is in progress and the module accepts another summary report request, the report initiated by the new request is appended to a report already in progress. The age timer for the report is reset every time the module accepts a summary report request. The log does not print until the age time elapses.

Guidelines

Normally, request a summary report only when none are already in progress. The RCM tag in a zero state identifies this condition. Do not set an RCM target state to zero if it is currently set to a one state while the module is processing a requested report.

Sequence of Events Logs

The *Log by Name* function gives the ability to print or display SOE logs that are retained on the hard disk. An SOE log, no matter what type, is identified by the file name assigned to it by the console. SOE logs are saved in individual files for each configured log.

The file name identifies the log and retention of that log. The file name format is **SOECL nnn .Ln**. For example, the log file **SOECL012.LO** identifies SOE log index number 12 and retention one. The most recently completed log is retention number one (e.g., **LO**). The retention number increases to correspond to chronologically older retentions with a maximum of nine (e.g., **L8**). The oldest saved copies are removed as new ones are created.

To print or display a copy of an SOE log:

1. After selecting the *Log by Name* option, the following prompt appears:

Log Name/Index ___ *Retention* ___ *Print/Display* ___

Enter the log name in the *Log Name* field. The log name must be completely spelled out. It must also follow the format:

SOECL nnn

where:

nnn Log number to print. For example, enter **SOECL012** for SOE log number 12.

2. Enter a number from 1 to 9 in the *Retention* field to determine which retained log to print or display. Use 1 to print the most recently saved copy or any number from 2 to 9 for older saved copies.
3. Enter either **PRINT** or **DISPLAY** in the *Print/Display* field.
4. Press **ENTER** to initiate the request. A printout occurs at the printer designated in the configuration of a log.

Refer to **Display Log Operations** in this section for information on how to move the display presentation.

Printing the Events and Operator Actions Logs

Both system events and operator actions must be saved to the hard disk for either periodic printing or *Log by Name* printing. The events log configuration allows separating event items and

operator action items into an event log and an operator actions log for printing purposes.

The events saved to disk capacity is approximately 1,000 most recent events (minimum of 1,000 events). An option available during event log configuration allows scheduling an automatic print cycle for the event log and operator actions log. Use the *Log by Name* function at any time to print a current list of saved events even if the logs are scheduled to print automatically. The *Log by Name* function prints the most recently saved events.

To print the event log:

1. After selecting the *Log by Name* option, the following prompts appears:

Log Name/Index ___ *Retention* ___ *Print/Display* ___

Enter **0** or the name **EVENT** in the *Log Name/Index* field. These are reserved to identify the event log.

Enter **ACTION** to print the operator actions log.

2. In the *Retention* field, enter the number of most recently saved events to print. This number is an approximation. At a minimum, that many events appear in the printout if that many were saved. Use 0 to print all saved events. Also, if the entered number is greater than the actual number of saved events, all events print.

3. Enter **PRINT** in the *Print/Display* field.

4. Press **ENTER**. The printout occurs at the printer designated in the event log configuration.

Displaying the System Event Log

The *Log by Name* option gives the ability to display the system event log. The display can operate in two modes: Real-time and snapshot. System event log configuration determines the types of events that appear on the display (and in the printed log). Only those events defined to print or save to disk appear in the display of the event log.

The display log function allows specifying search criteria to limit the information displayed. This does not affect the snapshot version of the displayed event log or the printed or saved version.

Refer to ***Display Log Operations*** in this section for information on how to move the display presentation. Refer to ***CALLING IN SNAPSHOT MODE*** in this section for an explanation of

additional methods for moving the presentation available only for the snapshot event log.

NOTE: The system event log can be separated into an event log and operator actions log during configuration. If this option was chosen, operator actions do not appear in the display of the event log.

CALLING IN REAL-TIME MODE

When in real-time mode, the screen updates with new events as they occur similar to the continuously printing event log. Events appear on a single page, with each event occupying one or two lines on the page. After the page becomes full, new events begin to scroll older events off the page. A new event can be identified by the greater than (>) symbol appearing in the margin. Figure 18-1 shows the display log function in real-time mode.

```

FRIDAY SEP 23, 1994 15:28:07 DISPLAY LOG FUNCTION
EVENT LOG DISPLAY - Realtime Mode
15:27:49 Output of Periodic Print of Alarm Summary at printer 3 was cancelled by OPERATOR at
15:27:49 Output of Periodic Print of Alarm Summary at printer 3 was cancelled by OPERATOR at
15:27:49 Output of Periodic Print of Alarm Summary at printer 3 was cancelled by OPERATOR at
15:27:49 Output of Periodic Print of Alarm Summary at printer 3 was cancelled by OPERATOR at
15:27:49 Output of Periodic Print of Alarm Summary at printer 3 was cancelled by OPERATOR at
>15:27:49 Output of Periodic Print of Alarm Summary at printer 3 was cancelled by OPERATOR at
15:25:16 F-Trend Config: List 4 Entry 7; Low Limit is 0.00 was by OPERATOR at 5
15:25:16 F-Trend Config: List 4 Entry 7; High Limit is 100.00 was by OPERATOR at 5
15:25:42 F-Trend Config: List 4 Entry 8; Tag Name is RNR-00002 was by OPER
15:25:42 F-Trend Config: List 4 Entry 8; Low Limit is 0.00 was by OPERATOR at 5
15:25:42 F-Trend Config: List 4 Entry 8; High Limit is 60.00 was by OPERATOR at 5
15:26:03 F-Trend Config: List 4 Entry 8; is DELETED by OPERATOR at 5
15:26:17 F-Trend Config: List 4 Entry 7; is DELETED by OPERATOR at 5
15:27:18 Output of Tag or Trend Summary at printer 3 was cancelled by OPERATOR at
15:27:49 Output of Periodic Print of Alarm Summary at printer 3 was cancelled by OPERATOR at
15:27:49 Output of Periodic Print of Alarm Summary at printer 3 was cancelled by OPERATOR at
15:27:49 Output of Periodic Print of Alarm Summary at printer 3 was cancelled by OPERATOR at
15:27:49 Output of Periodic Print of Alarm Summary at printer 3 was cancelled by OPERATOR at

1
K-1
P-1
CDN
TUN
SHF
A Define Single ARROW key Col C Create a New SNAPSHOT D Toggle Search Criteria OFF
B Previous SNAPSHOT Mode E Define Search Criteria
  
```

TPS0767B

Figure 18-1. Event Log Display - Real-Time Mode

CALLING IN SNAPSHOT MODE

In snapshot mode, the page presents both the current events at the time of the request and all events currently saved on the hard disk. A snapshot file of the event log is created when the display is called or is switched to snapshot mode. The snapshot file contains the information that is seen on the screen. The snapshot file contents is not updated unless the *C Create a New SNAPSHOT* option is chosen or the display is called up again in the new snapshot mode. When either is performed,

the following message appears while the data for the snapshot log is being compiled:

EVL processing copy request

Refer to **CALLING THE DISPLAY AND SELECTING THE MODE** in this section for the procedures to call the event log display in the new snapshot mode. Figure 18-2 shows the display log function in snapshot mode.

```

FRIDAY  SEP 23,1994 15:51:42 DISPLAY LOG FUNCTION
FILE : 0.3F:DLG-EVTS.TP
SEP 23,1994 DIS UNIT 2 EVENT LOG
15:39:28 Output of Tag or Trend Summary at printer 3 was cancelled by OPERATOR
15:39:28 Output of Tag or Trend Summary at printer 3 was cancelled by OPERATOR
15:39:28 Output of Tag or Trend Summary at printer 3 was cancelled by OPERATOR
15:39:28 Output of Tag or Trend Summary at printer 3 was cancelled by OPERATOR
15:39:29 DRD-04669 138 P198M10 DRDIG#2
15:39:34 DRD-05065 139 P198M20 DRDIG#1
15:39:34 DRD-05069 139 P198M20 DRDIG#2
15:39:40 D0188180685 170 INDEX 8763
15:39:44 ANALOG-0001 0 L 99 LITRES ANALOG TAG 0001
15:39:44 DIG-00065 ZERO 111 DIGITAL TAG 0065
15:39:44 DIG-00020 ONE R111 50 SECOND STATE CHANGER
15:39:49 STR-02077 57 LD 24 P205M8 BASIC STATION #1
15:39:49 DRD-04669 138 P198M10 DRDIG#2
15:39:50 STR-02077 0 L 24 P205M8 BASIC STATION #1
15:39:54 DRD-05065 139 P198M20 DRDIG#1
15:39:54 DRD-05069 139 P198M20 DRDIG#2
15:40:00 D0188180685 R170 INDEX 8763
1
K-1
P-1
CON
TLN
SHF
A Define Single ARROW key Col C Create a New SNAPSHOT ARROW keys, NEXT/PREV PAGE,
B Switch to REALTIME mode and HOME key position file.

```

TPS0768B

Figure 18-2. Event Log Display - Snapshot Mode

The initial information displayed is the top of the snapshot file which is the oldest information chronologically. Press **NEXT PAGE** to view newer entries. Continue to press the key until the *End of File* appears. This marks the bottom of the snapshot file. The events at the end of the file are the most recent entries in the log. Press **PREV PAGE** to view older events.

Press **HOME** while at the top or anywhere in the middle of the snapshot file to quickly move to the bottom of the file. Middle refers to anywhere in the file except the top or bottom. Press **HOME** while at the bottom of the file to quickly move to the top of the file.

CALLING THE DISPLAY AND SELECTING THE MODE

To display the event log:

1. After selecting the *Log by Name* option, the following prompt appears:

Log Name/Index ___ *Retention* ___ *Print/Display* ___

Enter a **0** or the name **EVENT** in the *Log Name/Index* field. These are reserved to identify the event log.

2. In the *Retention* field, enter one of the following selections depending on the desired mode for the display log:

R - real-time mode.

P - calls a previous snapshot. Use this to call the initial or last updated version of the snapshot file.

S - initiates a new snapshot. Use this to update the snapshot file and call the new version.

Leaving the *Retention* field blank calls the display log in real-time mode.

3. Enter **DISPLAY** in the *Print/Display* field.

4. Press **ENTER**.

Select Mode

Choose option *B* after calling the display log in either mode to switch between real-time mode and previous snapshot mode. Choose option *C* while in either real-time mode or snapshot mode to update the snapshot file and to switch to new snapshot mode.

SPECIFYING A SEARCH CRITERIA

A search criteria can be defined when displaying the event log. The search criteria can be used to limit the information to only a single type of event or to several types of events. The search criteria affects the data presented in real-time mode only.

The search criteria can be turned on or off using an option available while the page is in real-time mode (Figure 18-1). It can be turned on or off at any time. Choose *D Toggle Search Criteria ON/OFF* to toggle the search criteria.

To specify search criteria:

1. Either call or put the display log in real-time mode. Refer to **CALLING THE DISPLAY AND SELECTING THE MODE** in this section for the procedures.

2. Choose *E Define Search Criteria*. Figure 18-3 shows the page that appears next.

```

FRIDAY JUL 08, 1994 14:18:59 DISPLAY LOG FUNCTION
Search Criteria
From MON 13 1994 08:00:00
To JUN 20, 2004 08:00:00

Tag Name : *
Tag Index : 1 to 10000
Alarm Group : 1 to D
Tag Type :
Ring : Node : Mod : Block :

-----EVENT TYPE-----
State Change YES Operator Action YES
Alarm Event YES Operator Notes YES
Information YES

-----ALARM STATE-----
No Alarm YES High YES Good YES
Digital Alarm YES Low YES Bad YES
Bad Quality YES Two High YES Disestablished YES
High Deviation YES Two Low YES Substituted YES
Low Deviation YES Three High YES Suspect YES
Hardware Alarm YES Three Low YES Alarm Inhibited YES

-----TAG QUALITY-----
1
K-B
P-1
con
tun
SHF
ALT

```

TPS0769C

Figure 18-3. Event Log Display - Search Criteria

3. Enter the appropriate data into each field of the page. Refer to Table 18-1 when defining the fields of the search criteria page.

4. Press **ENTER** to update the search criteria.

5. Press **ESC** to return to the previous page.

Table 18-1. Display Log - Events Retrieval Page Fields

Field	Description
From	Starting time and date at which to begin a search for events.
To	Ending time and date at which to stop a search for events.
Tag name ¹	Name of the tag for which to retrieve events. Wild card characters (i.e., * and ?) can be used when specifying a tag name. Enter an asterisk or clear the field to not use tag name as a search constraint. An asterisk specifies all tag names.
Tag index: __ to __ ¹	Range of tag index numbers to retrieve. A valid entry is from 1 to 30,000. Enter the maximum range or clear the fields to not use tag index number as a search constraint.
Alarm group: __ to __ ¹	Range of alarm groups to retrieve. Valid range entries are 1 to 99, and S. The complete alarm group range is from 1 to S. Enter the maximum range of 1 to S or clear the fields to not use alarm group as a search constraint.
Tag type	Enter any valid tag type. Clear the field or leave it blank to not use tag type as a search constraint.

Table 18-1. Display Log - Events Retrieval Page Fields (continued)

Field	Description
Ring ___ node ___ mod ___ block ___	Enter a valid loop, node, module, and block address to which to limit the search. Clear the fields or leave them blank to not use tag address as a search constraint.
Event type	YES = search for event type. NO = do not search for event type. NOTE: At least one event type field must be set to YES.
Alarm state	YES = search for alarm state type. NO = do not search for alarm state type.
Tag quality	YES = search for tag quality type. NO = do not search for tag quality type.

NOTE:

1. At least one of these fields must have an entry.

LOG STATUS

The *Log Status* function provides a status overview of both configured custom logs and SOE logs. It also allows changing the status and canceling queued (pending) prints for individual or an entire group of these types of logs. Each entry in a log status page details the information pertaining to a single log.

A log must be turned on or made active to begin its data collection. When to activate a log depends on its purpose. A log can be activated as the last step when configuring if desired. It also can be left inactive at the time of configuration and made active later using log status functions.

Taking a log from an active status to an inactive status ceases any further data collection. When data collection is no longer required or a log is to be reconfigured, it must be made inactive.

The log status function provides two methods for changing the status of a log. It can be changed directly from the *TARGET STATUS* field of a status page or it can be changed from an action menu.

The action menu appears after making a menu selection from the opening page of the log status function or by pressing **ESC** from any log status page. The action menu has the following options:

Activate - changes status to *ACTIVE*, which turns data collection on.

Deactivate - changes status to *INACTIVE*, which turns data collection off.

Cancel reports waiting to print - cancels queued prints.

All log status operations start from the log status menu (Figure 18-4). To call the menu:

1. Press **MISC MENU**.
2. Select *A Log Status*.

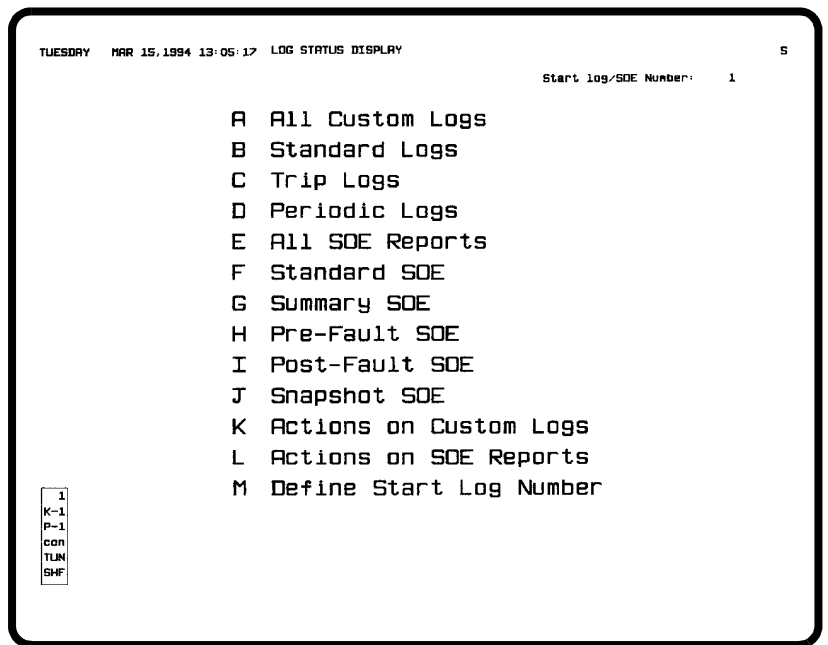

Figure 18-4. Log Status Menu

Options *A* through *D* call a status page for all or a specific type of custom log. Options *E* through *J* call a status page for all or a specific type of SOE log. After selecting one of the options, a status page containing a list of requested logs appears. The status page allows directly activating or deactivating individual logs or an action menu can be called from the page.

The log status function can show the status of up to 300 custom logs or 160 SOE logs. Each status page for a custom log displays eight log entries. Each status page for an SOE log displays 16 log entries.

Options *K* and *L* call an action menu. This gives the ability to change the status and to cancel any queued print for a log without having to call a status page. Refer to **Action Menu Operations** in this section for an explanation of operations performed from this menu. Refer to **Selecting a Start Log** for a description of option *M*.

Selecting a Start Log

The log that is to appear as the first entry on a status page is selectable. This prevents having to press the paging keys several times to find a desired entry.

To select the start log:

1. From the log status menu (Figure 18-4), select *M Define Start Log Number*. A *Select the Start Log Name/Index* field appears.
2. Enter the name of a custom log or its number from 1 to 300. Or, enter the number of an SOE log from 1 to 160. Enter a name for a custom log only. If an undefined log name or an invalid log number is entered, an error message requesting a valid log name or number appears.
3. Press **ENTER**.

The *Start Log/SOE Number* field at the top of the log status menu page (Figure 18-4) updates to show the index number of the starting log. Initially, the log status function defaults to *1*. When selecting items *A* through *E*, the first entry that appears on the status page is the one shown in this field. If the number is greater than the 160 limit for SOE logs, the status page defaults to entry number one.

Custom Logs Status Page

A status page for a custom log contains the same information whether selecting the *All Custom Logs* option or one of the specific log type options. Figure 18-5 shows an example of a custom log status page. Select any custom log option to call a display similar to the one shown in this figure. The log status functions performed from this page are explained later in this section.

The top lines of the page provide an explanation of the information detailed in each log entry. From left to right, top to bottom, the information for each entry includes:

LOG NUMBER - number assigned during configuration. The log numbers range from 1 to 300. Enter this number when using the *Log by Name* function. Refer to **PRINTING AND DISPLAYING LOGS** in this section for a description of the log by name function.

TARGET STATUS - any requested status change. A log status change can be made directly from this field or by using the action menu activate or deactivate options.

WEDNESDAY 17-AUG-1994 08:29:47 ALL CUSTOM LOGS 1 2 3 4 5 6 7 8 9 10 11 12 13 14 15 16 17 18 19 20 A

LOG NUMBER	TARGET STATUS	CURRENT STATUS	LOGNAME	LOG DESCRIPTOR	COMPLETION TIME	COLLECTION PERIOD	LOG TYPE			PRINT TYPE	
							AA	BB	CC		
30	INACTIVE	ACTIVE	LOG30	LOG ALL TAG TYPES	17-AUG-1994 13:20:00	20 MINUTES	PERIODIC	NO	2	4	COLLECT
31	ACTIVE	ACTIVE	LOG31	TREND LOG TEST	17-AUG-1994 09:30:00	1 HOURS	STANDARD	NO	1	4	COLLECT
32	ACTIVE	ACTIVE	LOG32	TREND LOG TEST WITH FORMULAS	17-AUG-1994 13:25:00	1 HOURS	STANDARD	NO	0	4	COLLECT
33	ACTIVE	ACTIVE	LOG33	TRIP LOG TEST WITH FORMULAS		40 MINUTES	TRIP	NO	0	4	COLLECT
34	ACTIVE	ACTIVE	LOG34	TRIP LOG TEST WITH FORMULAS		10 MINUTES	TRIP	NO	0	4	COLLECT
35	ACTIVE	ACTIVE	LOG35	POST-TRIP TREND LOG WITH FORMULA		0 MINUTES	TRIP	NO	0	4	COLLECT
36	ACTIVE	ACTIVE	LOG36	TRIP LOG TEST WITH FORMULAS		6 MINUTES	TRIP	NO	0	4	COLLECT
37	INACTIVE	INACTIVE				0 UNDEF	UNDEF	NO	0	1	COLLECT

1
K-1
P-1
CON
TUN
SHF

TPS0182B

Figure 18-5. Log Status Display - Custom Logs

CURRENT STATUS - actual log status. The field remains at its current indication after a status change has been requested until processing of the change request has completed. The field normally updates after a short time to show the same status as the targeted status.

LOGNAME - name assigned to the log during its configuration. Enter this name when using the *Log by Name* function. Refer to **PRINTING AND DISPLAYING LOGS** in this section for a description of the log by name function.

LOG DESCRIPTOR - log description as defined during configuration.

LOG TYPE - type as defined during configuration. The types are either standard, periodic, or trip.

COMPLETION TIME - estimated time of log completion. Either a start time defined for the log or the time the log was triggered plus its collection period determines the completion time. If the log is set to repeat its collection cycle, this field updates as each new collection period starts.

COLLECTION PERIOD - collection period defined during configuration. The collection period is the amount of time the log collects data. This field is not used for a trip log.

AA - repeat cycle status. It indicates whether the *Repeat Collection Cycle?* is enabled or disabled in the log configuration. If enabled, the log performs its data collection repeatedly. The log

stops collecting data after completing its initial collection period if the repeat cycle is disabled.

BB - number of logs waiting to print. If a designated printer is currently busy, this field will identify the number of logs that are queued but not printed.

CC - logical printer where the printout is to occur. This is defined during configuration.

PRINT TYPE - print type as either collect, event, demand, or time. The print type is defined during configuration. A collect type log prints as soon as it completes its collection period. An event type log prints after being triggered by a specific process event. A demand type does not print until initiated with the *Log by Name* function. Refer to **PRINTING AND DISPLAYING LOGS** in this section for a description of the log by name function. A time type log prints at a defined time.

SOE Logs Status Page

A status page for an SOE log contains the same information whether selecting the *All SOE Reports* option or one of the specific log type options. Figure 18-6 shows an example of an SOE log status page. Select any SOE log option to call a display similar to the one shown in this figure. The log status functions performed from this page are explained later in this section.

WEDNESDAY 03-AUG-1994 09:18:11 ALL SOE REPORTS R

SOE NUMBER	TARGET STATUS	CURRENT STATUS	REPORT TITLE	REPORT TYPE	SER #	REPORTS WAITING	PRINTER #
1	ACTIVE	ACTIVE	SOE REPORT 1	SUMMARY	1	0	2
2	ACTIVE	ACTIVE	SOE REPORT 2	SUMMARY	2	0	2
3	ACTIVE	ACTIVE	SOE REPORT 3	SUMMARY	3	0	2
4	ACTIVE	ACTIVE	SOE REPORT 4	SUMMARY	4	0	2
5	ACTIVE	ACTIVE	SOE REPORT 5	SUMMARY	5	0	2
6				UNDEF			
7				UNDEF			
8				UNDEF			
9				UNDEF			
10				UNDEF			
11				UNDEF			
12				UNDEF			
13				UNDEF			
14				UNDEF			
15				UNDEF			
16				UNDEF			

1
K-1
P-1
CDN
TLN
SHF

TPS0183C

Figure 18-6. Log Status Display - SOE Logs

The top lines of the page provide an explanation of the information detailed in each log entry. From left to right, top to bottom, the information for each entry includes:

SOE NUMBER - number assigned during configuration. The SOE numbers range from 1 to 160.

TARGET STATUS - any requested status change. A log status change can be made directly from this field or by using the action menu activate or deactivate options.

CURRENT STATUS - actual log status. The field remains at its current indication after a status change has been requested until processing of the change request has completed. The field normally updates after a short time to show the same status as the targeted status.

REPORT TITLE - log title defined during configuration. The title also appears in a printout.

REPORT TYPE - type of log as defined during configuration. The type appears as either standard, summary, predefault, post fault, or snapshot.

SER # - SER number assigned during configuration. An SER number associates a list of tags to a particular recorder, SOE (FC 210) function block, or SEM module.

REPORTS WAITING - shows the number of logs waiting to print. If a designated printer is busy, this field will identify the number of logs that are queued but not printed.

PRINTER # - identifies at which logical printer the printout is to occur. This is defined during configuration.

Status Page Operations

Options *A* through *J* of the log status menu call the status page for all or a selected group of custom logs or SOE logs (Figure 18-4). Press **NEXT PAGE** and **PREV PAGE** to view additional pages after selecting any of these options.

The status page provides two options for changing log status. The first is by changing the *TARGET STATUS* column of a log entry to either active or inactive. The second is from an action menu.

After calling a status page, an input cursor appears in the *TARGET STATUS* column of the first log entry. The input cursor allows changing the status of the log on which it is positioned.

To change the status:

1. Move the cursor within the *TARGET STATUS* column. When on the desired log, enter **ACTIVE** or **INACTIVE** to change the status.
2. Press **ENTER** after making all status changes to initiate a change request. As soon as processing of the request is completed, the *CURRENT STATUS* column will update to the targeted status.

Press **ESC** to call the action menu. Refer to **Action Menu Operations** in this section for an explanation of action menu options.

Action Menu Operations

An action menu is called in two different ways. From the log status menu page, select *K Actions on Custom Logs* or *L Actions on SOE Reports* (Figure 18-4). Or, press **ESC** from any status page.

The action menu is basically the same for both a custom log and an SOE log. The only difference is that the custom log menu items use the term *Log(s)* and the SOE log menu items use the term *SOE(s)*. The action menu options include:

- A Activate Log(s)*
- B Deactivate Log(s)*
- C Cancel reports waiting to print*
- D Activate all Logs displayed*
- E Deactivate all Logs displayed*

Options *D* and *E* do not appear when calling the action menu from the log status menu.

ACTIVATING LOGS

To activate custom or SOE logs:

1. Call the action menu. Refer to **Action Menu Operations** in this section for the methods.
2. Enter **A** in the input field.
3. Press **ENTER**. One of the following prompts appears depending on the type of log:

Activate Log Number ___ thru ___

- or -

Activate SOE Number ___ thru ___

The input fields allow specifying either a single log or a range of logs to activate.

4. Key in the starting log number in the first input field. If a single log is being activated, skip the next step.
5. Key in an ending log number in the second input field.
6. Press **ENTER**. The following message appears as each status change request is processed for each log in the range:

Activation Submitted for log/SOE # nnn

A status change request can be seen in the *TARGET STATUS* column of a status page. The *CURRENT STATUS* column will verify the completion of a requested status change.

To activate the eight currently displayed custom logs or 16 SOE logs from a status page:

1. Press **ESC** to call the action menu.
2. Enter **D** to select *Activate all Logs displayed*.
3. Press **ENTER**.

DEACTIVATING LOGS

To deactivate custom or SOE logs:

1. Call the action menu. Refer to **Action Menu Operations** in this section for the methods.
2. Enter **B** in the input field.
3. Press **ENTER**. One of the following prompts appears depending on the type of log:

Deactivate Log Number ___ thru ___

- **or** -

Deactivate SOE Number ___ thru ___

The input fields allow specifying either a single log or a range of logs to activate.

4. Key in the starting log number in the first input field. If a single log is being deactivated, skip the next step.
5. Key in an ending log number in the second input field.

6. Press **ENTER**. The following message appears as each status change request is processed for each log in the range:

Deactivation Submitted for log/SOE # nnn

A status change request can be seen in the *TARGET STATUS* column of a status page. The *CURRENT STATUS* column will verify the completion of a requested status change.

To deactivate the eight currently displayed custom logs or 16 SOE logs from a status page:

1. Press **ESC** to call the action menu.
2. Enter **E** to select *Deactivate all Logs displayed*.
3. Press **ENTER**.

CANCELING WAITING LOG PRINTS

The *Cancel reports waiting to print* option cancels all or selected reports waiting to print for a log. The *BB* column for custom logs or *REPORTS WAITING* column for SOE logs identifies the number of logs waiting to print. The cancel print function can be used to cancel any print jobs currently in process or any number of older reports waiting to print.

To cancel queued prints for a log:

1. Call the action menu. Refer to **Action Menu Operations** in this section for the methods.
2. Enter **C** in the input field.
3. Press **ENTER**. The following prompt appears:

Cancel from Report # ___ to Report # ___ for Log # ___
4. In the first input field, enter the number of the first waiting log to cancel.
5. In the second input field, enter the number of the last waiting log to cancel.
6. Enter the name (custom logs only) or the number of the log for which to cancel waiting print jobs in the last input field.
7. Press **ENTER** to initiate the cancellation.

Example: A status page indicates a 4 in the report waiting column for log number five. Of the four, the oldest three waiting to print are to be canceled. Enter a 2 in the first input field and a 4 in the second field. This specifies all waiting reports from two to four.

Enter a **5** in the last field to designate log number five. After entering, reports two through four clear leaving report one as the only queued report waiting to print.

SECTION 19 - ARCHIVE DATA

INTRODUCTION

The console provides the ability to record process related information. One method of recording the data is digitally on a storage medium. The other is in a hard copy log explained in [Section 18](#).

This section explains data archiving, the data types that can be archived, and the procedures to retrieve stored data. The archiving function provides an integrated method for storing and retrieving process information and both console and INFI 90 OPEN operational information.

ARCHIVING

Archiving extends normal console storage of logs, PCU configurations, system events, trends, and tag data indefinitely. After archiving is set up, data is automatically collected and stored to an archive medium. The medium is either magnetic tape or optical disk. After data is archived, archival retrieval functions or tag historian functions can be used to retrieve data for printing or display. The *Archival Storage/Retrieval* option gives access to both archive data storage functions and archive data retrieval functions.

NOTE: Magnetic tape refers to digital audio tape or TK50 cartridge. This console does not support the nine-track magnetic tape or floppy disk for archiving.

Logs and events can be archived to an open access system (OAS). The open access system provides the ability to archive data to magnetic tape or optical disk medium.

The archive data storage functions turn on storage for individual data types and automatically direct archiving of data to a specific storage medium or to an open access system. In some cases, a manual store of data or use new volume action may be required during archival storage to prevent data loss.

The archive data retrieval functions provide directory and retrieve data options. A directory of either an archived volume of data or retrieved data can be viewed. A retrieve data option provides a method of retrieving any type of data from a medium for display and printing.

The operator information and operator request for action pages work directly with the archiving functions. The operator information events page provides a running list of archival operations for both storage and retrieval requests. Refer to

OPERATOR INFORMATION EVENTS in Section 17 for more information. The operator request for action page is used to indicate that some action is required before processing of an archive operation can be continued. An operator action request indicator (flashing A) appears at the title line to indicate a request for action. The operator request for action page normally indicates what the attempted operation was, then allows continuing after satisfying the request. Refer to **OPERATOR ACTION REQUESTS** in Section 17 for more information.

The different data types that can be archived include:

- Logs (after collection period completion).
 - Trend log (standard type custom log).
 - Trip log (trip type custom log).
 - Snapshot log (periodic type custom log).
 - Sequence of events log.
- Trends.
 - Enhanced.
 - Standard.
- Events (list of system events and operator actions).
- Tag data.
 - Analog tag snapshots.
 - Digital tag exceptions.
 - Alarms.
- PCU configurations.

Any of the data types in any combination can be put on any single medium. However, individual data types cannot be split up to go to more than one medium. Only logs and events can be archived to an open access system.

ARCHIVE DATA STORAGE

The setup of archival storage directs several operations:

- Allocates disk space for temporary storage.
- Enables each data type for storage.
- Schedules archiving.

Archiving should be considered prior to trend, tag, and log configuration since attributes set during these configurations relate to archiving. Archiving can, however, be enabled at any time. Complete archival storage configuration requires first defining archival operating parameters, then configuring individual data types to be archived.

The *Archival Configuration* option sets up the operating parameters as they pertain to archival storage. This must be

completed first since attributes set during this configuration allocate hard disk space for archived data storage and turn archiving on for each data type to be archived.

The configuring of individual data types establishes the specific logs, events, PCU configurations, tags, and trends that are to be archived. These configurations define the data that is collected and stored in hard disk files for eventual transfer to a medium or open access system.

Not all data types have to be set to archive when archiving is being configured. Therefore, not all of the procedures that follow are always required. Either one data type, several data types, or all data types can be stored in a single archive to medium if desired.

Disk Space

A function of archival storage is to allocate hard disk space used for temporary storage of archived data. Any data to be archived is stored in an archival storage directory. The data remains in this directory until being transferred to a storage medium or an open access system. Data that was previously stored for transfer is overwritten with new data after it has been transferred to a medium. This is done in preparation for the next archive to medium.

Data Type Storage

A function of archival storage is to enable each data type that is to be eventually archived. However, archival storage enables an entire type of data for storage rather than specific data. The actual data that archives depends on the configuration of individual functions and tag historian configuration. These configurations determine the specific data that archives. For example, each configured custom log can be set to either archive or not archive based on its *To Be Archived?* attribute.

Log configuration enables the storage of individual custom, SOE, and system event logs. Trend definition enabled trend data storage. PCU management functions store PCU configurations that are to be archived. The tag historian function provides the capability to store tag data (i.e., exception reports and tag database data).

Scheduling an Archive

The last responsibility of archival storage is to schedule when and to which type of medium data is transferred. Data transfer can occur from every four hours to every 99 weeks. Scheduling depends on the amount of data being stored. Some data types, such as tag data, consume a large amount of hard disk space and require a shortened archive to medium schedule.

After archival storage is set up, it becomes automatic except for an occasional requirement to install a new storage medium. The operator actions function prompts to identify any archival requirements such as installing or initializing a new medium, disk space allocation reaching maximum capacity, a failed attempt to archive, etc.

Data stores to media in volumes of data. A volume name defined during data type to volume definition identifies information stored on a medium. A hexadecimal sequence number is assigned to each medium. The sequence number increments for each new medium being used to store data. The sequence number also increments when using the archival menu *Use New Volume* option. This function is explained later in this section.

For example, the medium storing a volume named *TAGS* becomes full. The console had assigned a sequence number of 0003 to that medium. The new medium installed to continue with the archival storage of volume *TAGS* will be assigned a sequence number of 0004.

The sequence number and volume name do not apply for data being archived to an open access system. The open access system does not use nor require either. The volume name defined during archival storage is therefore only informational, but still required by the console. The open access system assigns a volume name and sequence number to data it stores to medium. The data stored to an archive medium by an open access system can be retrieved from the medium with the console by specifying a sequence number and volume name.

In cases where data has been stored by an open access system or another console and the data is to be retrieved by this console, the volume name and sequence number must be known to retrieve the data. Use the *Directory of Archive Volume* option to acquire this information from a particular medium.

Although data archiving is normally automatic, there may be some instances when forcing data to store to medium or an open access system or when forcing the console to use a new medium is required. The *Store Data* and *Use New Volume* options provide these capabilities.

Setting Up Archival Storage

Three procedures are required to set up archival storage. All work together to establish archiving operating parameters:

- Data type to volume definition.
- Volume to media definition.
- Miscellaneous definitions.

HARD DISK DATA STORAGE

Archival storage must be set up to automatically store data to the console hard disk for eventual transfer to a storage medium or to an open access system. The data, established during configuration of the individual types of data, stores in archive data files. These files contain the data collected that will eventually be archived.

The parameters defined while setting up archival storage affect all data types. Archived data resides temporarily in a reserved area on the hard disk. The amount of hard disk space reserved for archiving is established when setting up archiving. Each data type competes for this reserved space. Storage to hard disk of trend, tag, event, log, or PCU configuration data must be enabled before any data can be archived.

The tag historian function provides the capability for storing, archiving, and retrieving tag data (i.e., exception reports and configuration data). Since the initial archival storage and retrieval of tag data is handled the same as other types of data, the same media and options are available. Archived tag data that has been retrieved can be printed for up to 100 tags at a time.

Hard disk storage for archived data is temporary. After being configured, specific data is collected and saved in hard disk files until a scheduled archive time or time interval is reached. The data is then archived to a storage medium. After archiving all saved data, old data in these archive data files is overwritten with new data in preparation for the next archival storage. This sequence repeats until archiving is disabled. When archived to medium, process data storage becomes more permanent.

The amount of hard disk space that can be used for archival storage depends on the total amount of unused disk space available. A disk space for archiving allocation and a disk space for data retrieval allocation are made with the miscellaneous definitions function.

To limit storage of archived data to a reasonable amount, the disk space for archiving allocation is used as a limit for data storage. To prevent data loss, additional hard disk space will be used as necessary. This is done in anticipation of some data files being deleted after archiving to medium. If for some reason archiving to medium cannot take place (e.g., medium not installed or wrong volume), new data begins to overwrite old data resulting in loss of archived data.

MEDIA STORAGE

Archived data automatically stores to a medium after reaching a defined time or time interval. An archive to medium consists of only the data saved during the defined time interval. The files for archived data contain only one type of data. Any combination of these data files can be stored on any one medium. Two options are used to determine which data stores on a particular medium: data type to volume definition and volume to media definition.

OPEN ACCESS SYSTEM STORAGE

Archived logs and events automatically store to an open access system after a defined time or time interval. Before an automatic archive can occur, the following are required:

1. Identifying the OAS node with OAS definition procedures. Refer to the discussion on open access system configuration in the **Configuration** instruction for the procedures (Table 1-2 lists instruction numbers).
2. Identifying the type of data that is to store to the open access system (i.e., events and logs) during archival storage setup.

As with archiving to medium, the files for archived data to be sent to an open access system contain only one type of data. Two options are used to determine the data that stores to an open access system: data type to volume definition and volume to media definition.

DATA TYPE TO VOLUME DEFINITION

Data type to volume definition does three different things:

- Turns archiving on or off for each data type.
- Assigns a volume name to each data type.
- Sets the console overwrite priority.

An on/off attribute acts as a master switch to enable or disable archiving of each type of data. Archiving can be enabled or disabled for individual data types. This affects both media storage and hard disk storage.

Each archived data type requires a volume name. This is used to group individual data types into a single volume for archiving to a single medium. All data types to be included in a single volume should have the same volume name.

Archiving hard disk space is limited. If this space is completely consumed, new data begins to overwrite old data. An overwrite

priority sets the order used to overwrite old data. The lowest numbered data type is overwritten first.

Use the *Data Type to Volume Definition* option to set the data type to volume definitions. Figure 19-1 shows the display used. To choose the option, first press **GENL FCTNS MENU**, then select the following menu items in the sequence shown.

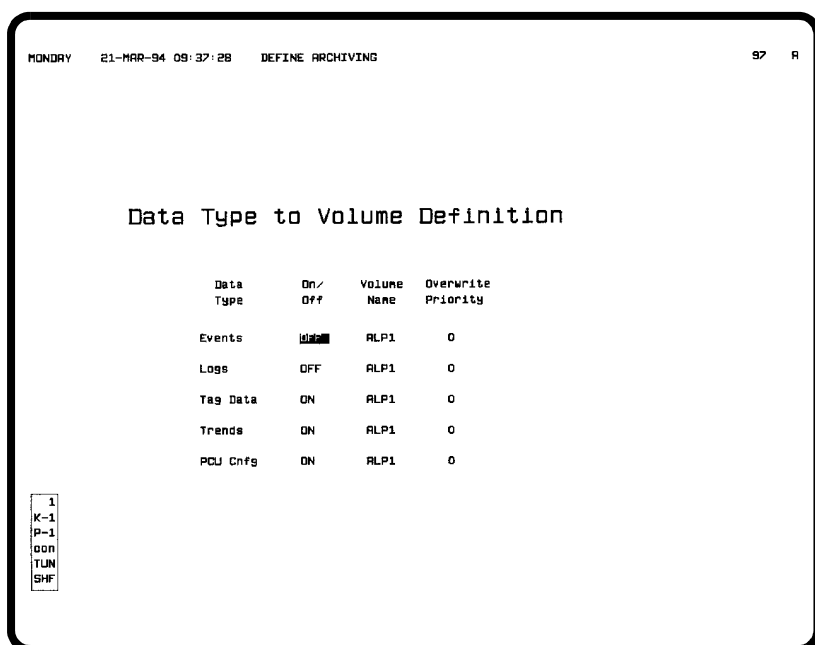
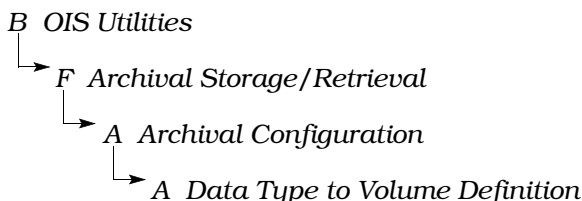

TPS0010C

Figure 19-1. Data Type to Volume Definition

The data types (*Events*, *Logs*, *Tag Data*, *Trends*, and *PCU Configuration*) can be segregated as individual volumes of data or consolidated in any combination into one volume of data. However, a data type cannot be split between volumes.

When changing a data type from on to off, all files containing data already collected for the data type are deleted from the hard disk. This data then does not archive at any time to a storage medium. To prevent loss of archived data, it is suggested that this change not be made until after a scheduled archive to medium completes or the *Store Data* option is used to force data storage. Refer to **Store Data** in this section for an explanation.

To define a data type to volume definition:

1. Enter **ON** in the *On/Off* field for the data type to enable archiving of that type of data; enter **OFF** to disable archiving. This acts as the master switch for the data type.

For example, the *Trends* field is *ON*; the *Logs* field is *OFF*. All trends that are set to archive in their definition will archive, while logs do not archive even if they are set to archive in their configuration.

If the *On/Off* field is turned on for a data type, the *Volume Name* cannot be left blank. An error message appears if the name is blank and **ENTER** is pressed.

2. Enter a four-character volume name in the *Volume Name* field. The name appears when performing volume name to media definition.

For archiving to medium, the *Volume Name* field defines the name assigned to a volume of data archived to the medium. Assigning the same volume name to other data types groups them for transfer to a single medium. When archiving data to an open access system, the name is used only to group data types and is not required for OAS purposes. This is **not** the type of medium. The type of medium a volume of data stores to is determined during volume to media definition.

If the volume name of data stored on an installed medium does not match the name configured here when it is time to archive data, an operator action request is used to prompt for the correct volume.

If the *Volume Name* field was previously defined, it cannot be cleared at any time in the future. The volume name can be changed, however, at any time. If attempting to clear the name, the following message appears:

Volume Name previously defined cannot be blank

3. In the *Overwrite Priority* field, enter a priority. This determines the order in which old data is overwritten in the event archiving exceeds its allocated disk space. The lowest numbered data type is overwritten first.
4. Press **ENTER**.

VOLUME TO MEDIA DEFINITION

After the volume names are defined in data type to volume definition, volume to media definition:

- Assigns the type of medium to which a volume of data archives.
- Assigns descriptive text to identify a volume of data.
- Sets the time of day that archiving to medium occurs.
- Sets the time interval between each archive to medium after the initial start time.

A medium type must be assigned to each volume of data. This determines to which medium the volume stores. Remember that a volume of data includes all data types that have the same volume name.

When attempting to archive a volume of data, the storage device is first checked for an installed medium. The installed medium is then checked for a volume name. If the medium was previously used and contains a volume of data with a name that does not match the volume being archived, the console generates an operator action request to install the correct volume. This can be a medium that contains previously archived data with the same volume name or a blank tape or optical disk.

The directory of an installed medium can be read by the console. The directory gives:

- Type of archive medium.
- Volume name.
- Sequence number.
- Beginning and ending time of each archived period.
- Number of events, logs, trends, tag data files, and PCU configurations stored during each archive period.

Refer to **Requesting a Directory of an Archive Volume** in this section for more information.

Use the *Volume to Media Definition* option to set the volume to media definitions. Figure 19-2 shows the display used. To choose the option, first press **GENL FCTNS MENU**, then select the following menu items in the sequence shown.

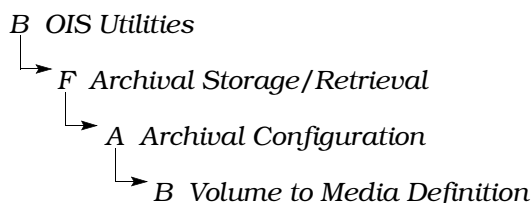

```

MONDAY 21-MAR-94 09:37:17 DEFINE ARCHIVING 97 R

Volume to Media Definition

Volume Name      Volume Descriptor      Media Type      Time Span      Time of Day
to Output Data
ALP1             MAG TRENDS AND LOGS    OPTICAL        4 HOURS        10:00

1
K-1
P-1
COM
TUN
SHF

```

TPS0225C

Figure 19-2. Volume to Media Definition

The page is used to configure each volume of data. It defines to which medium (i.e., magnetic tape, optical disk, or open access system) a volume should archive. The *Volume Name* field cannot be changed and reflects a volume name configured in data type to volume definition.

To create a volume to media definition:

1. In the *Volume Descriptor* field, assign a meaningful descriptor of up to 20 characters to describe the purpose of this volume of data. For example, it can show the type of data being stored such as *TRENDS AND LOGS*.
2. In the *Media Type* field, enter the type of medium to which this volume of data is to be stored. A valid entry is **MAGTAPE** or **OPTICAL** for all data types or **OAS** for the *Events* and *Logs* data types. The magnetic tape and optical disk options require additional hardware.

NOTES:

1. Examples of *Time Span* and *Time of Day to Output Data* field interaction and setting are given in **ARCHIVE SCHEDULING USING VOLUME TO MEDIA** in this section.
2. Magnetic tape (MAGTAPE) refers to digital audio tape. This console does not support nine-track magnetic tape.
3. The *Time Span* field determines how often the data will be written to storage medium or to an open access system. A valid entry is **4 HOURS**, **6 HOURS**, **8 HOURS**, **12 HOURS**, *nn DAYS*, or

nn **WEEKS**, where *nn* is a maximum of 99. Longer time spans require more hard disk space than shorter time spans.

4. In the *Time of Day to Output Data* field, enter a time that archiving to storage medium is to occur each day.

5. Press **ENTER**.

Considerations

The shortest valid time span for archiving is four hours. Some data types have special requirements when setting the time span for archiving.

The time span set in the definition of a standard trend must be at least the archive time span set during volume to media definition plus two hours. This provides some margin between trend storage and archive storage to prevent loss of archived data. It is the responsibility of the person setting up archiving to insure that this requirement is met.

If archiving an enhanced trend, the time span for archiving must be set to a value equal to or greater than the maximum event recording time (S8) for FC 179 set in the control configuration. This will guarantee that at least one new event will occur during an archival period. If it is not, gaps could appear in the trend line for historical data. It is the responsibility of the person setting up archiving to insure that this requirement is met.

ARCHIVE SCHEDULING USING VOLUME TO MEDIA

A time of day attribute sets the start time for archiving. A time span attribute sets the interval between archives. The frequency can be every four, six, eight, or 12 hours or any multiple of one day or week. The start time and the interval operate in conjunction with each other.

Time Span ≤ One Day

A time span equal to or less than one day (i.e., 24 hours) causes an initial archive of data to occur at a specified time of day, then at regular intervals after the initial archive. For example, an archive has a *Time of Day to Output Data* set for 13:00 (i.e., 1:00 P.M.). It also has a 12-hour *Time Span*. The first archive to storage medium does not take place until 13:00. The data in this initial archive is all data saved between the time starting at completion of archiving setup and 13:00. Additional archives continue to occur at 1:00 and 13:00 daily. The initial archive does not contain a full 12 hours of data, but subsequent archives contain 12 complete hours of data.

Time Span > One Day

A time span greater than one day causes the initial archive to occur at the defined time of day after completing the initial time span period. Additional archives occur regularly at the defined time span interval and at the defined time of day. For example, an archive has a *Time of Day to Output Data* set for

17:30 (i.e., 5:30 P.M.). It also has a seven-day *Time Span*. The first archive to storage medium does not take place until 17:30, six days after the first 17:30 time passes. This is because the first day in the seven-day count is from the time starting at completion of archiving setup to 17:30 of the same day. The first day of the initial archive is not a complete 24-hour collection. Additional archives occur at seven-day intervals and at 17:30. These subsequent archives contain seven complete days of archived data.

An operator action request is generated if archiving does not take place at its scheduled time. The action request will identify the specific actions that must be taken to continue processing. If no action is taken, new data will begin to overwrite old data resulting in loss of archived data.

Considerations

Because the amount of tag data that stores on the hard disk can be considerable, the recommended frequency for tag data archiving to medium is at least once a day. The time interval between archives determines the amount of hard disk space files containing tag data consume. Tag data is automatically archived more frequently when necessary (e.g., no more hard disk space available). The storage medium must already be installed, however, when an attempt to archive data is made.

MISCELLANEOUS DEFINITIONS

Miscellaneous definitions:

- Allocates hard disk space for archival storage.
- Sets a disk fullness warning level.
- Allocates disk space for archive data retrieval.

Up to 40 megabytes of hard disk space can be reserved for archived data storage during setup. This allocation limits hard disk space consumed by archive data files, which prevents the archiving function from using so much space that other operations would not function properly. The amount to reserve depends on the amount of data being archived, the time span between archives, and the amount of available unused hard disk space. Additional hard disk space will be used if required to prevent data loss; however, there is still a limit to the amount of space available for temporary use.

A fullness warning level is used to notify when archived data has consumed a certain percentage of the disk space allocated for storage. When the percentage is reached, the following message appears on the operator information events page:

*ARCHIVAL: APPROACHING CONFIGURED DISK SPACE ALLOT-
MENT*

Use the *Store Data* option to force storage to a medium to prevent data loss. Some steps can be taken to prevent this message from appearing. If the fullness level is set to 90 percent and the storage allocation is maximum, the time span for archiving should be decreased. If the time span is already at its minimum of four hours, the only other option is to decrease the amount of data to be archived (e.g., turn off archiving for some data).

The following message appears if the allocated hard disk space fills completely:

Fullness warning level/100

If this occurs, some action must be taken to prevent loss of archived data. The action can be to decrease the amount of data being archived, decrease the time span, or increase the amount of hard disk space allocated for data storage. Decreasing the time span causes archiving to storage medium to occur at closer intervals reducing the amount of data stored on disk. A temporary solution is to force data to be archived by using the *Store Data* option. This removes the message temporarily but does not fix the problem.

Use the *Miscellaneous Definitions* option to set the operating parameters for archiving. Figure 19-3 shows the display used. To choose the option, first press **GENL FCTNS MENU**, then select the following menu items in the sequence shown.

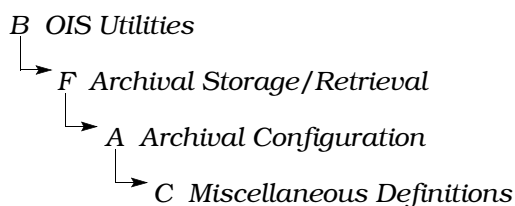

To define the operating parameters:

1. In the *Disk Space for Archiving* field, enter the amount of space to use for data storage. This limits the maximum amount of disk space that archival storage uses. A valid entry is from 1 to 40.

The value to enter depends on the quantity of data to be archived and the time span between each data type archive. The more data to be archived and the longer the time span, the larger this field should be. It should allow enough hard disk space for four archiving periods. After the fourth period, files for the oldest archiving data are replaced by the newest archived data. A starting value of five megabytes is suggested.

The amount of hard disk space used for tag data storage varies. The space tag data occupies depends on the number of

```

MONDAY 21-MAR-94 09:37:35 DEFINE ARCHIVING 97 R

Miscellaneous Definitions

Disk Space for Archiving 30.0 M
Fullness Warning Level 80 %
Disk Space for Retrieval 40.0 M

1
K-1
P-1
CON
TUN
SHF

```

TPS0227C

Figure 19-3. Miscellaneous Definitions

exception reports received for each tag, the amount of configuration data of each tag, and the amount of time between archives to medium. For example, at a rate of ten exception reports every second collected over 24 hours with a tag type distribution of 50 percent analog, 30 percent digital, and 20 percent station, 1,000 tags generate approximately 17 megabytes of data in one day.

2. Enter a percentage of disk space in the *Fullness Warning Level* field. The entry in this field determines when the following message appears on the operator information events page:

ARCHIVAL: APPROACHING CONFIGURED DISK SPACE ALLOTMENT

The level is based on the amount of *Disk Space for Archiving* that archival storage has consumed.

3. The *Disk Space for Retrieval* field limits the amount of disk space that archival retrieval uses. A valid entry is from 1 to 40. The value to assign to this field depends on how much data is to be retrieved and depends on how many other functions are competing for disk space. A starting value of one megabyte is suggested. Refer to **Retrieving Data by Type** in this section for the data retrieval procedures.

4. Press **ENTER**.

Setting Up Data to be Archived

Some data types must be properly configured to archive when scheduled. In most cases, this requires setting an archive attribute to enable storing the data to hard disk for eventual transfer to a storage medium. The following sections describe the configuration requirements. Refer to the **Configuration** instruction for the actual configuration procedures (Table 1-2 lists instruction numbers).

EVENTS

Events and operator actions related to tags defined in the database can be archived. Individual types of events can be enabled for archiving during tag configuration. These event types include alarms, digital state changes, and operator actions. Each is enabled separately. After tag configuration is complete, system event log configuration then provides the master switch for enabling storage to the hard disk.

The same data that appears in a periodic printout of a system event log (or operator actions log) appears in an archive of events. Operator actions and system events are not separated in an archive as can be when printing. Before any archiving of events can occur, first each tag event must be saved to disk, then archiving of those events saved must be turned on.

NOTE: Changes made to these configuration pages also affect printing of events and operator actions logs.

To set up archiving of events:

1. Enable events for tags to be archived.
 - a. Follow the procedures for editing a tag given in the **Configuration** instruction. The tag configuration page has three attributes that enable storing tag events for a tag: *Alarm - Save*, *State Change - Save* and *Optr Acts - Save*. These fields also enable saving data for periodic printing of events and operator actions.
 - b. Enter **YES** in the *Save* field for each type of tag event to enable storing that type of event; enter **NO** in the field to disable storing the type of event. This must be performed for all tags that are to have events or operator actions archived.
2. Enable event log operating parameters for archiving.
 - a. Follow the procedures for defining the system event log operating parameters given in the **Configuration** instruction.

b. At the top of the event log configuration page are fields that enable or disable the different types of tag events for saving to disk. An event must be saved for both periodic printing and archiving of events.

Enter **YES** in the *Save* field for each type of event to enable saving that type of event to disk. Enter **NO** in the *Save* field for an event type to disable saving that type of event to disk. If a *Save* field is set to *NO* for a type of event, that type of event will not be saved even if it is enabled in the configuration of a tag.

c. Enter **YES** in the *Archive Items Saved to Disk?* field to enable archiving of all events being saved. Enter **NO** in the field to disable archiving.

TREND DATA

Trends can be archived on a per trend basis. To set up a trend to archive:

1. Follow the procedures for trend definition given in the **Configuration** instruction.
2. Enter **ARCHIVED** in the *Trend Usage* field for the trend. This must be performed for each trend that is to be archived.

NOTE: Trend resolution defined in a trend definition for storing data is the resolution used in archiving.

CUSTOM LOGS

Custom logs can be archived on a per log basis. To set up a log to archive:

1. Follow the procedures for custom log configuration given in the **Configuration** instruction.
2. Enter **YES** in the *To be Archived?* field for the log to enable archiving. Enter **NO** in the field to disable archiving for the log. This must be performed for each custom log that is to be archived.

In order for the log to print and be archived, it must be active. A log can be activated from the log definition page during initial configuration or later with log status operations. A log archives only after completing its entire collection period.

SEQUENCE OF EVENTS LOGS

SOE logs can be archived on a per log basis. To set up archiving for an SOE log:

1. Follow the procedures for SOE report definition to configure a log to archive.
2. Enter **YES** in the *Archive* field for the log to enable archiving. Enter **NO** in the field to disable archiving for the log. This must be performed for each log that is to be archived.

PCU CONFIGURATIONS

Besides turning PCU configuration archiving on with data type to volume definition, there is no other configuration to perform to enable archiving of configurations. After being turned on, saving a configuration with PCU management functions automatically stores the configuration in an archive data file. The configuration is then archived to medium when scheduled in volume to media definition or after using the *Store Data* option.

TAG DATA

NOTES:

1. This section discusses the *Historian Group Configuration* option of the tag historian only. This option defines the tag data that is to archive. Refer to **Tag Historian** later in this section for information on the *Tag Historian Retrieval* and *Print/Delete RDF* options.
2. The tag historian does not support TEXTSTR tags.

The *Tag Historian* option sets up tag data for archiving. To collect and store tag data for archiving, a tag must be part of a tag historian group. Up to ten groups can be defined, each group containing up to 100 tags. Both exception reported data and database configuration data are recorded for a tag. Recording both allows data to be recalled regardless of database changes. Data archives to medium automatically at a frequency defined while setting up archival storage.

Tag historian functions also provide tag data retrieval and printing abilities. Retrieval is performed by alarm group, historian group, specific tag names, or wild card tag names.

Collection for a tag historian group can be activated or deactivated at any time. A group can be modified while active (i.e., tags can be added or deleted).

Use the *Historian Group Configuration* option to enable and define tag data archiving. To choose the option, first press

GENL FCTNS MENU, then select the following menu items in the sequence shown.

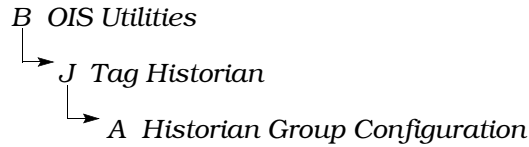

To define or edit a tag historian group:

1. Select a group.
 - a. In the *Enter Historian Group Number* field, enter the number of a group. A valid entry is from 1 to 10.
 - b. Press **ENTER**. Figure 19-4 shows an example of the configuration page. If the group has previously been defined, the name of each tag assigned appears. Also, the *Group Status* field may indicate *ACTIVE*. A group can be edited while it is active.

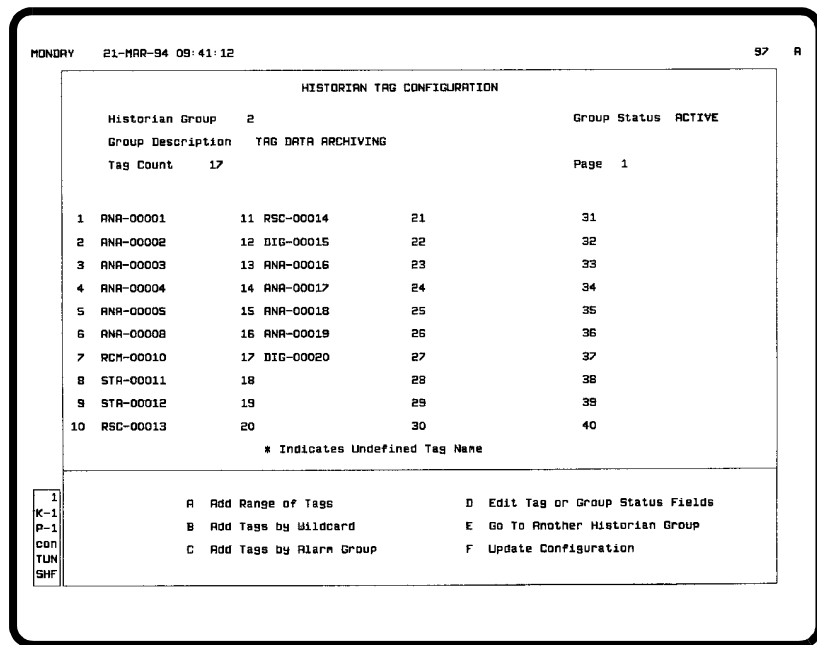

TPS0049B

Figure 19-4. Historian Group Configuration

2. Use one of the add options or the edit option from the menu to enter tags into the historian group list. These options are explained in the sections that follow.

When tags are added, the *Tag Count* field increments to indicate the current number of tags in the list. An asterisk (*) appears next to the name of a tag in the list if that tag has been either renamed or removed from the database.

3. After editing or entering all tags in a list, select *D Edit Tag or Group Status Fields*. This places the input cursor on the *Group Status* field.
4. If *INACTIVE*, enter **ACTIVE** to start data collection and storage for this group. If already *ACTIVE* go to the next step.
5. Select *F Update Configuration* to save any changes and to begin data collection. If edits are made without saving, the following prompt appears:

Edits Were Made - Update Configuration!!

If another group requires editing, select *E Go To Another Historian Group*. Or, press **NEXT PAGE** or **PREV PAGE** to go to the next or previous group respectively.

Add Options

Use the add options to add a new list of tags or to append to an existing list of tags. Adding tags by specifying a range, wild card name, or alarm group does not duplicate tags that already appear in a historian group.

If more than 100 tags are specified, the tag list is updated, but any tags over the 100 limit are not added. A warning appears if this occurs. Control returns to the bottom line menu.

Any option can be used after calling a specific group with the *Enter Historian Group Number* field. This input field appears when the function is first called or after selecting *E Go To Another Historian Group*. The definition of the current group must be saved (i.e., option *F*) before using the *Go To Another Historian Group* option. If the current group is not saved first, the following prompt appears:

Edits Were Made - Update Configuration!!

This message appears when attempting to exit without saving. If no changes have been made to the group, either exit or select option *E* without saving first.

Add Range of Tags

Use the *A Add Range of Tags* option to specify a consecutive range of tags or a single tag to add. After selecting the option, the following prompt appears:

Tag Index ___ To ___

To enter a range, specify the first tag in the range in the first input field. Enter the last tag in the range in the second field.

To enter a single tag, enter the same tag index number in both fields.

Press **ENTER** to add the specified tags to the group and to update the page. Press **ESC** before pressing **ENTER** to cancel all inputs and return control to the options menu.

Add Tags by Wild Card

Use the *B Add Tags by Wildcard* option to enter tags by specifying a search pattern and range. Select the option; the following prompt appears:

Wildcard Pattern ___, Tag Index ___ To ___

Enter the wild card pattern to be used when searching for tag names, then enter a tag range. The tag range is optional. The default is the entire tag database range.

The asterisk (*) and question mark (?) are reserved for wild card use. The asterisk represents multiple characters, the question mark a single character. For example, ABC*XYZ retrieves any tag beginning with ABC and ending with XYZ with any number of characters in between. ABC?XYZ retrieves any tag beginning with ABC and ending with XYZ and only one character in between. Any combination of * and ? can be used. The system supports multiple occurrences of ?. Multiple occurrences of * are treated as ? after the first *.

Press **ENTER** to add the specified tags to the group and to update the page. Press **ESC** before pressing **ENTER** to cancel all inputs and return control to the options menu.

Add Tags by Alarm Group

Use the *C Add Tags by Alarm Group* option to enter tags by specifying an alarm group range and tag range. Select the option; the following prompt appears:

Alarm Group ___ to ___, Tag Index ___ To ___

The entire tag range is from 1 to S (i.e., 1 to 99, and S). To enter an alarm group range, specify the starting alarm group of the range in the first input field. Enter the last alarm group of the range in the second input field. To enter a single alarm group, enter the same alarm group number in both fields. The tag range is optional. The default is the entire tag database range.

Press **ENTER** to add the specified tags to the group and to update the page. Press **ESC** before pressing **ENTER** to cancel all inputs and return control to the options menu.

Edit Tag or Group

Use the *D Edit Tag or Group Status Fields* option to view the entire list of tags in the group and to modify the list. Also, use the option to activate or deactivate the group. Select the option; the input cursor is initially positioned on the *Group Status* field. The *Tag Count* field increments or decrements to show the current number of tags in the list as tags are added or deleted. There are three pages associated with each group. Press **ESC** at any time to cancel all inputs and return control to the options menu.

To view the entire list of tags in the group:

1. Select *D Edit Tag or Group Status Fields*.
2. Press **NEXT PAGE** or **PREV PAGE**. The *Page* field indicates the current page.

Enter **ACTIVE** in the *Group Status* field to activate the current group and enable data collection.

Enter **INACTIVE** in the *Group Status* field to deactivate the current group and disable data collection.

To delete a tag:

1. Move to a specific tag name in the list.
2. Press **CLEAR** to delete the tag name.
3. Select *F Update Configuration*.

To add or change a tag:

1. Move to an available location in the list to add a tag. Move to a specific tag name in the list to change the name.
2. Enter the name or index number of the tag to add. Type a new tag name or index number to change the current tag to another.
3. Select *F Update Configuration*.

If the entered tag name or index number is invalid, an error message appears and the input cursor positions on the tag in error.

Store Data

The *Store Data* function can be used to manually initiate a data archive to medium or to an open access system. After

archiving is properly configured, this function should not be necessary at any time unless forcing data storage is desired.

This function is usually not required as long as archival storage has been set up to allow enough storage space on the hard disk and the time span between archives to medium is not too great. Both must be considered when initially setting up archiving. Archiving to an open access system only requires considering the hard disk space available for archiving. Some data types require more temporary storage space on the hard disk than others. Refer to **ARCHIVE DATA STORAGE** in this section for further explanation.

One example of when this function would be required is if the following message appears on the operator information events page:

ARCHIVAL: APPROACHING CONFIGURED DISK SPACE ALLOTMENT

This message indicates that the hard disk space allocated while setting up archival storage has reached a certain fullness level. If this occurs, the data must be stored immediately or soon after to prevent data loss.

Another example of a use for the *Store Data* option is to archive PCU configurations. Since PCU configurations cannot be set to save automatically with PCU management, a scheduled archive to medium may not always be desired. In this case, any configurations saved for archiving can be forced to store to medium immediately after being saved using PCU management.

A store data menu provides options for storing events, logs, tag data, trend data, or PCU configurations (Figure 19-5). To call this menu, first press **GENL FCTNS MENU**, then select the following menu items in the sequence shown.

```
B OIS Utilities
  |
  |→ F Archival Storage/Retrieval
      |
      |→ E Store Data
```

To store data:

1. Select any option *A* through *E* depending on the desired data type to store. A *Press ENTER to archive data* prompt appears after making a selection.
2. Press **ENTER** to confirm the store data request or **ESC** to cancel. Archive data storage activates for the selected data type and all other data types that archive to the same volume (have the same volume name assigned).

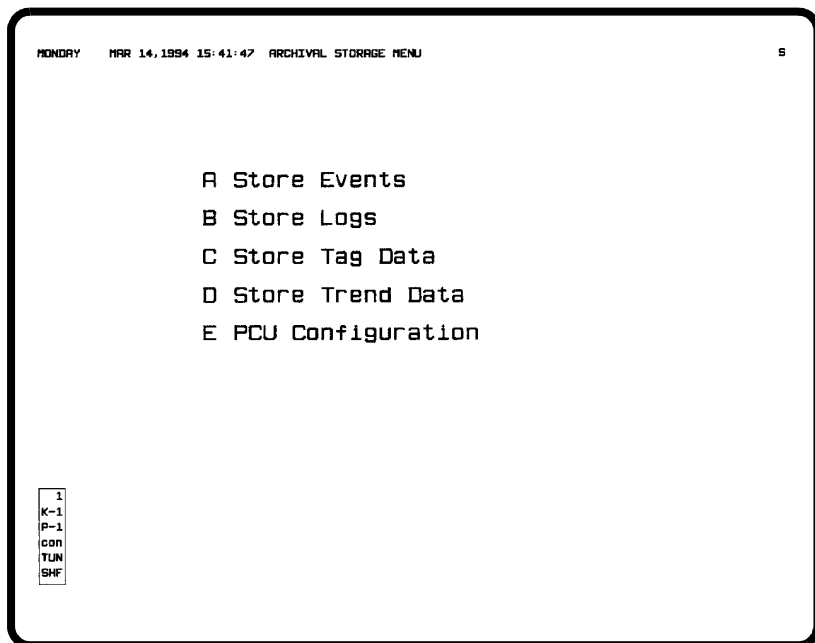

TPS0184B

Figure 19-5. Store Data Menu

If desired, call the operator information events page to view the progress of the store data operation.

Use New Volume

The *Use New Volume* option can be used to request that archiving for a selected data type be directed to a new volume (or medium). This action is usually only required when responding to an operator request for action or in an attempt to recover from an error. An example would be when the console tries to archive to a volume and an error occurs which cannot be resolved by retrying.

A use new volume menu provides options for requesting a new volume for either events, logs, tag data, trend data, or PCU configurations (Figure 19-6). To call this menu, first press **GENL FCTNS MENU**, then select the following menu items in the sequence shown.

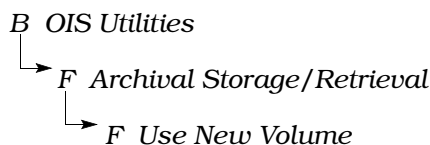

To use a new volume:

1. Select any option *A* through *E* depending on the desired data type for which to use a new volume. A *Press ENTER for action, ESC to cancel* prompt appears.

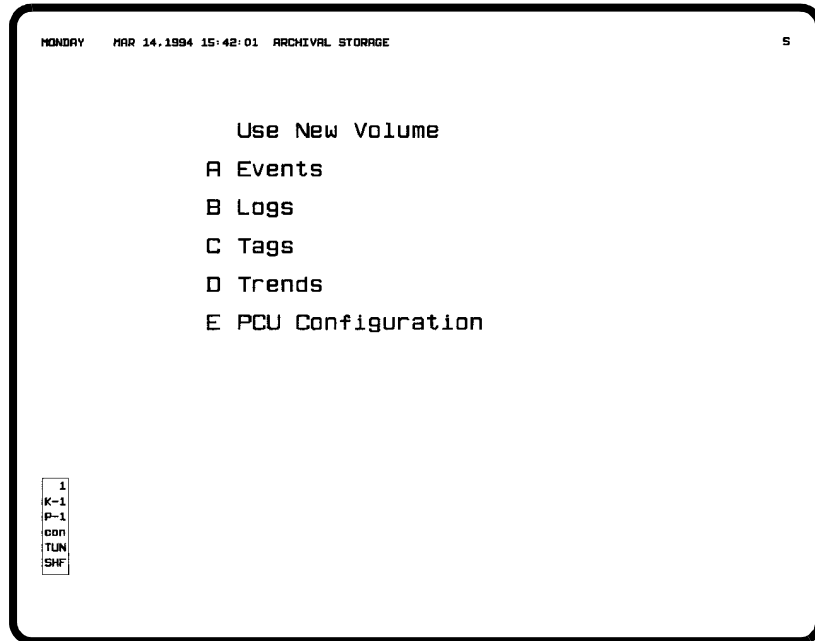

TPS0185B

Figure 19-6. Use New Volume Menu

2. Press **ENTER** to confirm the use new volume request or **ESC** to cancel. A new volume is used to store the selected data and all other data types that archive to the same volume (have the same volume name assigned).

After selecting any of these options, a request for action is made when the console is ready to archive to the new volume. The request will be to initialize a new installed medium. The request also identifies the name and sequence number that will be assigned to the volume of data upon initialization. The operator request for action must be processed completely before an archive to that medium occurs.

Responding to an Action Request

When the archive system tries to write to a volume and cannot for some reason, an operator action request is made. The request can be seen on the operator request for action page. The request may be to install the volume the console is trying to archive to or it may be to install a new medium if the current medium is full.

In the first case, the request can be satisfied by installing the medium that is to contain the volume of data, then processing the operator request for action. Responding to the action request is usually enough to continue. This assumes the medium has been used previously and has been initialized.

In the second case, a medium must be installed, then it must be initialized. After installing a new medium, then processing the operator request for action, another action request to initialize the volume is made. Responding to the initialize request is usually enough to continue.

Whenever archiving wants to initialize a new volume, it makes an operator action request stating the identity of the volume to be initialized and the identity of the volume mounted. A specific request to initialize the volume must be made.

Refer to **OPERATOR ACTION REQUESTS** in Section 17 for the procedures to process an action request.

Archival Error Recovery

Certain error indications during archiving may indicate a condition that cannot be corrected. Table 19-1 lists the error codes.

Table 19-1. Archiving Nonrecoverable Error Codes

Code	Cause
12	Trying to rewrite file. OIS application was reset during archiving.
283	Nonrecoverable hardware error. Bad spot on the medium.
284	Nonrecoverable hardware error. Bad spot on the medium.

If the error persists after retrying the operator action request, request that archiving use a new volume by using the *Use New Volume* option. After requesting a new volume, return to the operator request for action page and retry the action request. This time the console should respond with a request to initialize a volume for archiving.

ARCHIVE DATA RETRIEVAL

Archive data retrieval functions can be used to view or print data previously archived to medium during archival storage operations. The pages used to define data retrieval determine which data type and specific data to retrieve.

Data can be retrieved directly from a medium to which this console previously archived data or to which another console archived data. Data archived to an open access system cannot be directly retrieved from the open access system. It can, however, be retrieved from the medium to which the open access system archived the data. In these cases, the volume name and sequence number of the stored data may need to be specified.

For some data types, data is transferred back to the hard disk during retrieval. The retrieved data stores in archival retrieval directories.

The functions used to view or print retrieved data reference these directories. The data types transferred to the hard disk include:

Tag data - requires further retrieval by using the tag historian.

Trend data - viewed in a configured trend display.

PCU configurations - used in PCU management functions to download or verify configurations. PCU management also provides the ability to print retrieved configurations.

Any retrieved events or logs are printed when retrieved. No data is transferred to the hard disk. The printout is directed to the printer assigned to the window. Look at the keyboard status block to determine which printer.

Requesting a Directory of an Archive Volume

The console provides an archive directory function to view the contents of a volume of data stored on a medium. The information presented identifies the volume name and sequence number for the stored data. For each archive to medium, the directory also indicates the time span of data collected and the number of events, logs, trends, tags, and PCU configurations stored during that time span. The information is helpful and in some cases required when retrieving any data. Options for either printing or displaying a directory listing are provided.

A directory request is initiated from menu selections (Figure 19-7). To call the menu used, first press **GENL FCTNS MENU**, then select the following menu items in the sequence shown.

```

B OIS Utilities
  |
  |→ F Archival Storage/Retrieval
      |
      |→ B Directory of Archive Volume
  
```

Options *B* and *C* call a directory listing to the screen; options *E* and *F* print a listing. After selecting any of these, a volume search begins.

NOTE: Options *A* and *D* do not function for this console.

A magnetic tape or optical disk directory takes several minutes to complete. It is suggested that a printout of a directory be maintained with an archive medium to identify the volume of data stored.

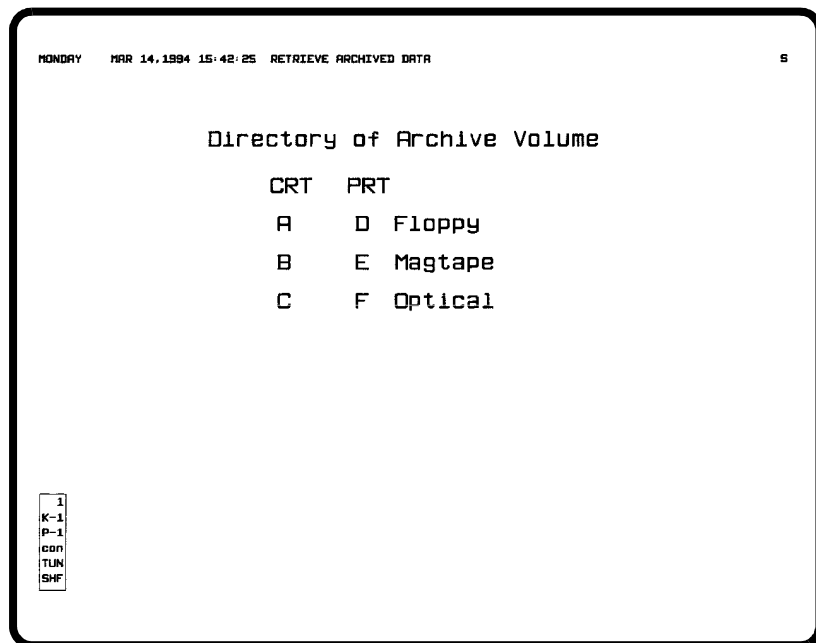

Figure 19-7. Directory of Archive Volume Menu

After selecting a display option, the following message appears:

Selection Made - Please Wait . . .

If the selected type of medium is not installed or the installed medium does not contain an archived volume of data, the following message appears:

Install Archive Volume and try again

After selecting a print option, the following message appears:

Retrieve archived data request queued

If the selected medium type is not installed or the installed medium does not contain an archived volume of data, the following message appears on the operator information events page:

Retrieval: No Valid Archive Volume is Installed

Figure 19-8 is an example of a displayed directory. The directory provides information necessary when performing archive data retrieval. The same information appears in a printout of the directory. Specifically, the information provided in a directory includes:

Archive Medium Type

The *Archive Media* field shows the type of medium chosen from the directory menu. The type appears as either *MAGTAPE* or *OPTICAL*.

```

MONDAY 21-MAR-94 14:22:43 RETRIEVE ARCHIVED DATA 97 A
                                DIRECTORY OF ARCHIVE VOLUME

Archive Media  OPTICAL
Volume installed RLP1 0001

Begin Time      End Time      Number  Number  Number  Number  Number
Events          Loss          Trends  Tags    PCU
                Configs

02:00:00 21-MAR-94   0        0       39      2       0
06:00:00 21-MAR-94   0        0       41      2       2
10:00:00 21-MAR-94  43       10      41      2       2
    
```

1
 K-1
 P-1
 con
 TUN
 SHF

TPS0226B

Figure 19-8. Example Archive Volume Directory Page

Volume Name and Sequence Number

The *Volume installed* field shows the volume name and sequence number of data stored on the medium. This name and number is searched for when retrieving data.

Archive Time

The *Begin Time* and *End Time* fields indicate the time that data collection began and ended for the data stored. Refer to this information when entering a from time and to time constraint for data retrieval.

The time span shown normally is the time span defined for data collection. This is set during volume to media definition. The exceptions to this are the initial data collection period and any forced data storage. The initial data collection in most cases does not contain data for a complete time span. Data can be forced to store to medium prior to completion of a defined time span by using the *Store Data* option. In this case, the time range is the beginning and ending times based on the time that data was stored by using the *Store Data* option.

Number Stored

The number of events, logs, trends, tags, and PCU configurations columns indicate the number of each data type stored during the time span.

Retrieving Data by Type

Archival retrieval functions allow directly printing archived logs and system events or transferring archived tag, trend, and PCU configurations back to the hard disk for use in other functions. All data types compete for the hard disk space

reserved for archival retrieval. The amount of space reserved is set with *Miscellaneous Definitions*. Refer to **MISCELLANEOUS DEFINITIONS** in this section for further explanation of disk space allocation.

After data is transferred to the hard disk, it resides in an archival retrieval directory. Each data type stores in its own directory. The functions that allow printing or viewing any retrieved data stored on the hard disk reference one of these directories to get the data. The archival retrieval function provides a directory function to view the contents of these directories.

Each data type has a separate retrieve data selection on the retrieve archived data menu (Figure 19-9). To call this menu, first press **GENL FCTNS MENU**, then select the following menu items in the sequence shown.

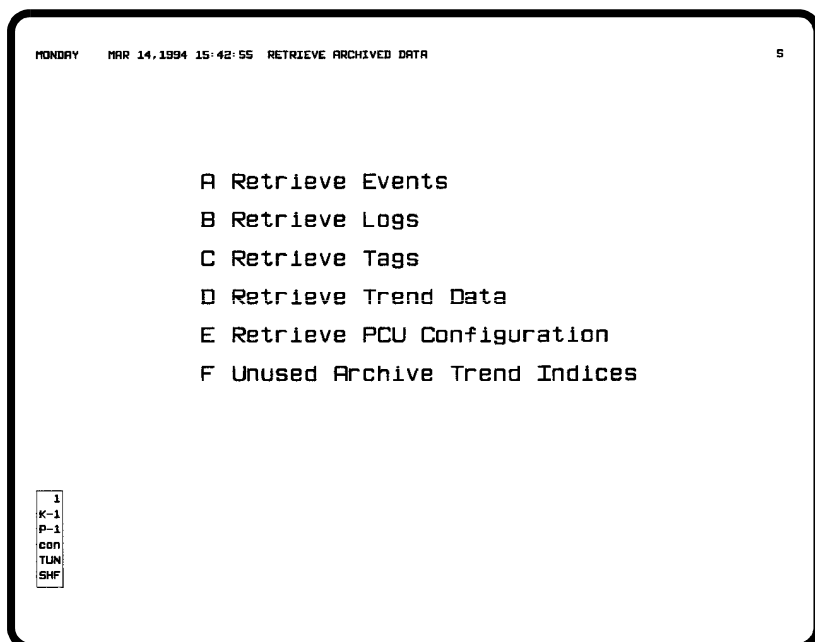
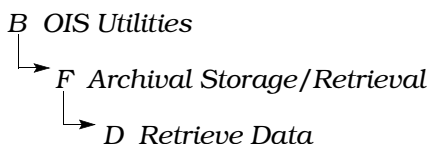

TPS0187B

Figure 19-9. Retrieve Data Menu

An archive medium search is based on constraints set on a retrieve data page. The page for a specific data type is called from a menu selection. Entered search constraints limit retrieval to certain types or ranges of stored data. Only data that matches or falls within the constraint limits set for the data type is retrieved.

To retrieve data:

1. Select any option *A* through *E*. The selection determines which type of data to retrieve. A retrieve data page for the selected data type appears after selection. The page allows entering the constraints used when retrieving data.

Use the *Directory of Archive Volume* option to determine the time span, volume name, and sequence number associated with data stored on a particular medium if unknown. Refer to ***Requesting a Directory of an Archive Volume*** in this section for the procedures.

2. Each data type has its own page and has different input requirements. Enter the appropriate data for the particular data type. Refer to ***Retrieving Data by Type*** in this section for an explanation of each field for each type of retrieval page.

NOTE: An entry in the *Media Type*, *Label*, and *Number* fields is usually only necessary when the installed medium to search is from another console. If retrieving from a medium that this console archived to, leave all three fields blank unless changes have been made to volume names since the original archiving. The console references its own archiving attributes when these fields are left blank. An entry must be made in all three fields or all must be left blank.

3. Press **ENTER** to initiate a retrieval request. Do **not** press **ENTER** until all constraint fields have been defined. The following message appears to indicate the start of a retrieval:

Retrieve Archive Data request queued

A medium is searched based on the entered constraints. Retrieval takes several minutes to complete. Press **ESC** at any time before pressing **ENTER** to exit the page without initiating a retrieval request.

NOTE: The retrieval operation initiated here can take a variable amount of time depending on the request and system load. The retrieval function runs as a background program. This allows exiting the page to perform other operations while a retrieval request is being processed.

If all inputs are valid, the request is processed. If not, the input cursor positions on the field in error. The status of a retrieval request can be seen on the operator information events page. The operator request for action page is used to indicate any required operator actions necessary to complete the processing of a data retrieval request.

After an installed medium is searched, an attempt to search the next or previous sequence numbered volume may be made. An operator action request message appears on the operator request for action page to identify the attempt. If this occurs, access the operator request for action page. A message

indicating which volume and sequence number the console is attempting to retrieve from appears on the page. When processing the action request, two options are available to continue the retrieval request. Either install the indicated volume or cancel the action request. Canceling clears the action request and causes the data that was retrieved from the currently installed medium to be stored onto the hard disk. Refer to **OPERATOR ACTION REQUESTS** in Section 17 for the procedures to process an action request.

Use the *Directory of Retrieved Data* function to view a listing of retrieved data. Refer to **Requesting a Directory of Retrieved Data** in this section for the procedures.

SYSTEM EVENTS

When system events are set to archive, all events archive. Archival storage does not allow storing only selected types of events. The archival retrieval function does, however, provide the capability to retrieve only specific types of events. The events related to a single or group of tags can be retrieved.

NOTE: Retrieved system events print only. They do not store on the hard disk in an archival retrieval directory.

Each retrieval request requires entering a time range, tag name, range of tag indexes, range of alarm groups, tag type, and tag address. The retrieve events page also requires selecting which types of events and the alarm conditions and qualities reported with each tag event to retrieve. The alarm condition and quality can be used to limit the events that are retrieved. An archived event must match or fall within **all** entered constraints to be retrieved.

Figure 19-10 shows the page used to retrieve events, which appears after selecting *A Retrieve Events* from the retrieve archived data menu. Table 19-2 explains each field of the page.

LOGS

Custom and sequence of events (SOE) logs are archived as log images. A log image is a completely formatted report ready for print. Archives are on a per log basis. A log does not archive until after completing its entire collection period. When retrieved, a log prints in the same format as when it was stored.

NOTE: Retrieved logs print only. They do not store on the hard disk in an archival retrieval directory.

The archival retrieval function provides the capability to retrieve either a single or range of stored custom and SOE logs. Each log retrieval request requires entering a time range, log

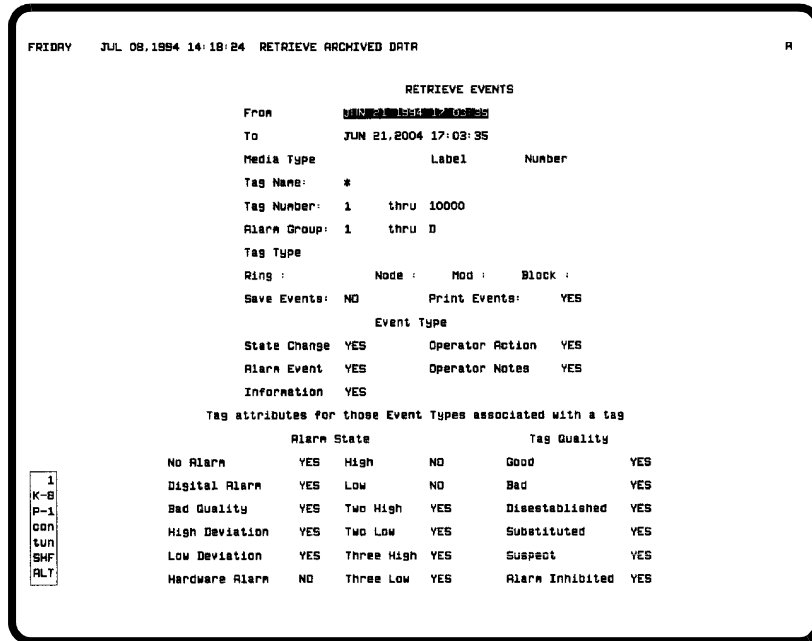

TPS0188C

Figure 19-10. Retrieve Events Page

Table 19-2. Events Retrieval Page Fields

Field	Description
From	Starting time and date from which to begin a search for events.
To	Ending time and date at which to stop a search for events.
Media type ¹	A valid media type is MAGTAPE or OPTICAL.
Label ¹	Volume name assigned to the events data type during <i>Volume to Media Definition</i> .
Number ¹	Sequence number assigned to the volume of data when stored.
Tag name ²	Name of the tag for which to retrieve events. Wild card characters (i.e., * and ?) can be used when specifying a tag name. Enter an asterisk to not use tag name as a search constraint. An asterisk character specifies all tag names.
Tag number __ thru __ ²	Range of tag index numbers to retrieve. A valid entry is from 1 to 30,000. Enter the maximum range to not use tag index number as a search constraint.
Alarm group __ thru __ ²	Range of alarm groups to retrieve. Valid range entries are 0 to 99, and S. The complete alarm group range is from 1 to S. Enter the maximum range of 1 to S to not use alarm group as a search constraint. Use 0 when the event is for a tag that is not assigned to an alarm group.
Tag type	Enter any valid tag type. Clear the field or leave it blank to not use tag type as a search constraint.
Ring __ node __ mod __ block __	Enter a valid loop, node, module, and block address to which to limit the search. Clear the fields or leave them blank to not use tag address as a search constraint.
Save events	Default is NO; leave this field at its default.
Print events	Default is YES; leave this field at its default.

Table 19-2. Events Retrieval Page Fields (continued)

Field	Description
Event type	YES = retrieve event type. NO = do not retrieve event type. NOTE: At least one event type field must be set to YES.
Alarm state	YES = retrieve alarm state event. NO = do not retrieve alarm state event.
Tag quality	YES = retrieve tag quality event. NO = do not retrieve tag quality event.

NOTES:

1. If retrieving from a medium archived to by another console, the media type, volume name, and sequence number are required. If retrieving from a medium that this console archived to, leave all three fields blank unless changes have been made to volume names since the original archiving.
2. At least one of these fields must have an entry.

type, log name, and range of log index numbers. An archived log must match or fall within **all** entered constraints to be retrieved.

Figure 19-11 shows the page used to retrieve log images, which appears after selecting *B Retrieve Logs* from the retrieve archived data menu. Table 19-3 explains each field of the retrieval page.

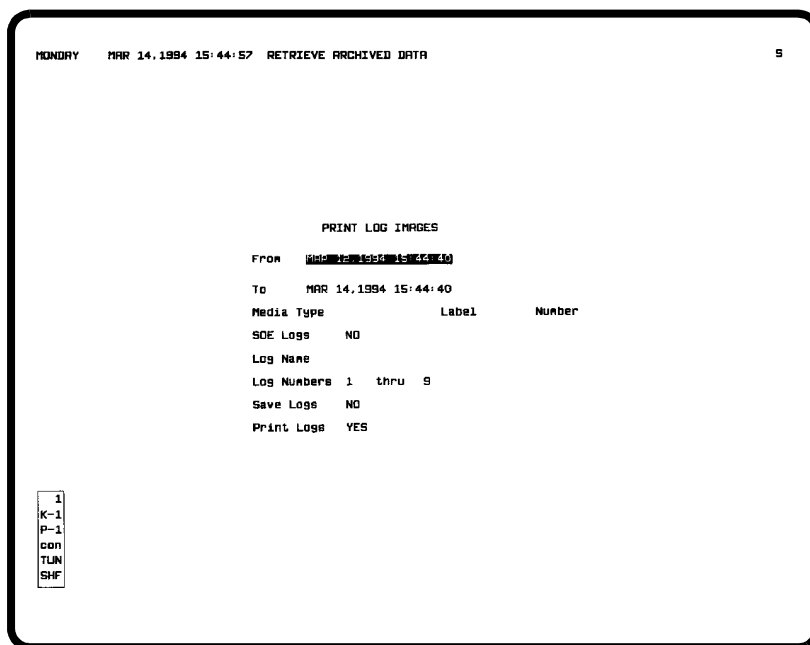

TPS0189B

Figure 19-11. Print Log Images Page

Table 19-3. Log Image Retrieval Page Fields

Field	Description
From	Starting time and date from which to begin a search for logs.
To	Ending time and date at which to stop a search for logs.
Media type ¹	A valid media type is MAGTAPE or OPTICAL.
Label ¹	Volume name assigned to the logs data type during <i>Volume to Media Definition</i> .
Number ¹	Sequence number assigned to the volume of data when stored.
SOE logs	YES = retrieve SOE logs. NO = retrieve custom logs.
Log name ²	When retrieving a custom log, enter the name defined for the log during its configuration. Enter the name in the format SOECL <i>nnn</i> where <i>nnn</i> is the report number for SOE logs. Wild card characters (i.e., * and ?) can be used when specifying a log name. Enter an asterisk to not use log name as a search constraint. An asterisk wild card character specifies all log names.
Log numbers _ thru _ ²	Range of log numbers to retrieve. Each log is assigned a log number during its configuration. Valid range entries are from 1 to 300 for custom logs or 1 to 160 for SOE logs. Enter the maximum range to not use log number as a search constraint.
Save logs	NO = default; leave this field at its default.
Print logs	YES = default; leave this field at its default.

NOTES:

1. If retrieving from a medium archived to by another console, the media type, volume name, and sequence number are required. If retrieving from a medium that this console archived to, leave all three fields blank unless changes have been made to volume names since the original archiving.
2. The log name and log number range entries can be used in conjunction or separately. For example, a log number range can be set to limit a search while the log name can be set to the wild card asterisk, which does not limit a search.

TAG DATA

The tag data that archives to storage medium depends on tag historian setup. The retrieval function transfers the tag data from the medium to the console hard disk. From there, further retrieval procedures must be performed by using the tag historian function. This function determines the exact data that is retrieved for printing. Refer to **Tag Historian** in this section for an explanation and for the procedures to perform the retrieval.

NOTE: The tag historian does not support TEXTSTR tags.

The archival retrieval function provides the capability to retrieve tag data by entering a time range. Archived tag data must fall within the entered time constraint to be retrieved.

Figure 19-12 shows the page used to retrieve tag data, which appears after selecting *C Retrieve Tags* from the retrieve archived data menu. Table 19-4 explains each field of the retrieval page.

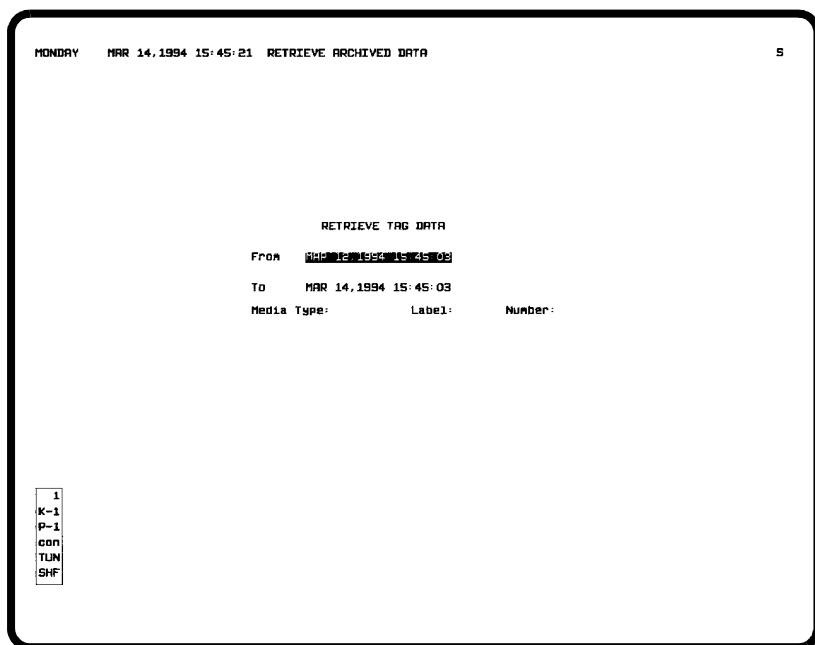

TPS0190B

Figure 19-12. Retrieve Tag Data Page

Table 19-4. Tag Data Retrieval Page Fields

Field	Description
From	Starting time and date from which to begin a search for tag data.
To	Ending time and date at which to stop a search for tag data.
Media type ¹	A valid media type is MAGTAPE or OPTICAL.
Label ¹	Volume name assigned to the tag data type during <i>Volume to Media Definition</i> .
Number ¹	Sequence number assigned to the volume of data when it was stored.

NOTE:

1. If retrieving from a medium archived to by another console, the media type, volume name, and sequence number are required. If retrieving from a medium that this console archived to, leave all three fields blank unless changes have been made to volume names since the original archiving.

TREND DATA

Trend data is archived on a per trend basis. During trend definition, the *Trend Usage* field for each defined trend determines whether its data stores for archiving or not. Trend data stores at the same resolution as set in the trend definition. The data can be retrieved, however, at a different resolution.

A trend does **not** have to be defined in the console to retrieve trend data and have it store in an archival retrieval directory. A trend definition is required, however, to view the data in a trend display. After a trend is retrieved and stored on the hard disk, it is referred to as a retrieved trend. The archival retrieval function provides the capability to retrieve either a single or range of trends.

Figure 19-13 shows the page used to retrieve trend data, which appears after selecting *D Retrieve Trend Data* from the retrieve archived data menu.

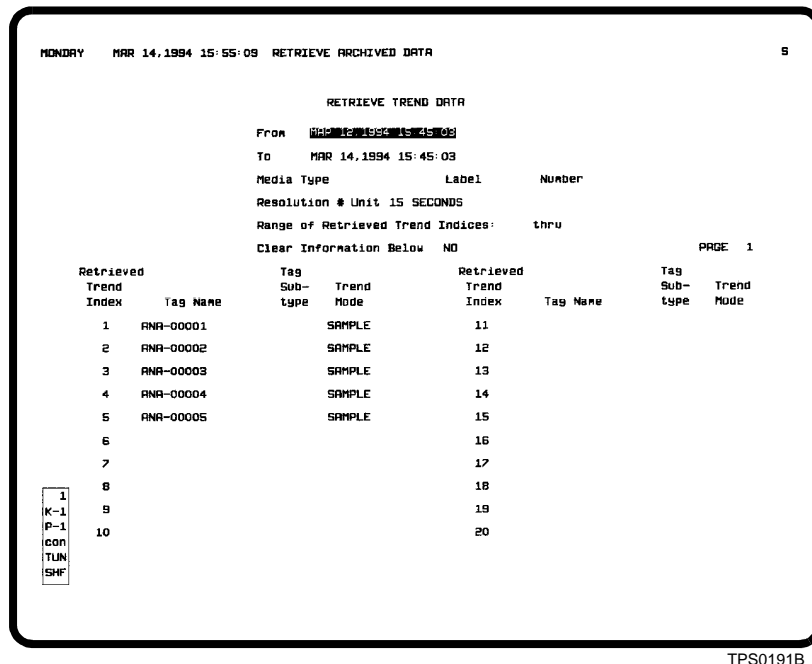

Figure 19-13. Retrieve Trend Data Page

Defining the Trend Retrieval List

The first step in trend data retrieval is to determine which trends to retrieve. Up to 80 trends can be retrieved at one time. When a trend is retrieved, it stores in its own file. Each trend is identified by an archive trend index number.

The fields at the bottom of the retrieve trend data page (Figure 19-13) define which trends will eventually be retrieved. Each trend in this list must correspond to a trend that has previously been archived. The trend retrieval list can be created at any time.

One way to define the retrieval list is to set it up at the same time as trend data storage. All trends (up to 80) that have their *Usage Type* field set to *ARCHIVED* can be included in the list. The print trend list utility allows printing a list of all trends having their *Usage Type* field set to *ARCHIVED*. All information required to add a trend to the retrieval list appears in the printout.

The archive index number assigned to a retrieved trend depends on its position in the trend retrieval list. The archive trend index number is only used by the archiving function and

is not the same as the trend index number assigned to a trend during its definition.

To enter a trend into the retrieval list:

1. An input cursor positions on the *From* field after initially selecting the *Retrieve Trend Data* option. Move the input cursor down the page to access the trend list fields.

Only 20 trend index numbers appear on a single page. Press **NEXT PAGE** or **PREV PAGE** to view the next or previous 20 entries.

2. Enter the name of the tag associated with the trend in the *Tag Name* column. The name must be the same as the tag name defined for the trend during its definition. Enter a tag name, not a tag index.

3. Enter the subtype in the *Tag Subtype* column if the trend is a STATION tag trend:

CO - control output (station)
PV - process variable (station)
RI - ratio index (station)
SP - set point (station)

Access to this field is not given unless the trend is a STATION tag trend.

Each variable related to a station block can be trended. A single station block may have several trends defined for that one block. The subtype entry is required to determine which trended variable of a station block to retrieve. In the case of a station trend, the trend list may contain several entries each having the same *Tag Name*, but each having a different *Subtype* entry.

4. Enter the data collection mode of the trend in the *Trend Mode* column. Enter either **AVERAGE**, **MINIMUM**, **MAXIMUM**, **RANGE**, **SAMPLE**, or **SUM**.

The *Tag Name*, *Tag Subtype*, and *Trend Mode* entries must match a stored trend exactly for the trend data to be retrieved.

Clearing the Trend Retrieval List

The trend retrieval list can be cleared at any time. This allows clearing the previous entries to redefine a new retrieval list. To clear the retrieval list:

1. Enter **YES** in the *Clear Information Below* field.
2. Press **ENTER** to initiate the clear.

Setting the Search Criteria

Table 19-5 explains the remaining retrieve trend data page fields that appear at the top of the page. Each retrieval request requires entering a time range, resolution, and range of trend indexes. Archived trend data must match or fall within all entered constraints to be retrieved.

Table 19-5. Trend Data Retrieval Page Fields

Field	Description
From	Starting time and date from which to begin a search for trend data.
To	Ending time and date at which to stop a search for trend data.
Media type ¹	A valid media type is MAGTAPE or OPTICAL.
Label ¹	Volume name assigned to the trends data type during <i>Volume to Media Definition</i> .
Number ¹	Sequence number assigned to the volume of data when stored.
Resolution # unit	Determines the resolution of the retrieved data. This does not have to match a trends defined resolution. If it does not, however, it should be a resolution that is greater than and a multiple of the resolution of the stored data. A valid entry is an integer from 1 to 99 and either SECONDS, MINUTES, HOURS, or DAYS. The console trend displays cannot display units in days. If the retrieval resolution is less than the resolution in which the data was stored, the data is retrieved at the resolution in which it was stored.
Range of retrieved trend indices ___ thru ___	Range of trend indices from the trend retrieval list (bottom of page) to be retrieved. A valid entry is from 1 to 80. Enter the same index number in both fields if retrieving data for only one trend. The range can include blank, undefined index numbers. Leave these fields blank to retrieve all trends defined on the current page of the trend retrieval list. NOTE: Any existing retrieved data files within this range are replaced with the newly requested data.

NOTE:

1. If retrieving from a medium archived to by another console, the media type, volume name, and sequence number are required. If retrieving from a medium that this console archived to, leave all three fields blank unless changes have been made to volume names since the original archiving.

Considerations Disk space for retrieved trends is established based on retrieval resolution. This is done since the trend type, either standard or enhanced trend, is not known at the time a request is made.

If a retrieval resolution for a standard trend is less than the resolution in which it was stored, disk space will be wasted. If it is known ahead of time that all trends being requested are standard trends, the retrieval resolution should be specified as the minimum resolution required, but a resolution equal to or a multiple of the stored resolution.

For an enhanced trend, the disk space allocation is adjusted to free up space when it is determined that the trend is an enhanced trend. If it is known ahead of time that all trends requested are enhanced trends, a large retrieval resolution

(i.e., ten minutes or greater) should be specified to minimize the amount of disk space initially allocated.

The display resolution for a trend element that is to display retrieved data must be:

- Same as the resolution of the data retrieved.
- Least common multiple of the resolution of the data retrieved.
- Any multiple of the resolution of the data retrieved.

Example: The display used to present trend data retrieved at five-minute resolution must be set up for five-minute display resolution or some multiple of five minutes (e.g., ten minutes). A resolution of less than five minutes is not valid.

Requesting a Trend Retrieval

A single, range, or all trends defined in the trend retrieval list can be retrieved in a single retrieval request. The recommended method to use when making a request is to retrieve fast trends (15-second), normal trends (one-minute) and enhanced trends in separate requests. This allows setting the resolution to retrieve data most efficiently to preserve hard disk space.

After initiating a retrieval request, any files containing previously retrieved data are deleted. The files that delete are only those for trends currently being retrieved in the current request. All other data files remain intact. A data file is also deleted if a *Retrieved Trend Index* entry is made blank and that index number is then requested for retrieval.

Define a new trend to retrieve in any unused *Retrieved Trend Index* number to leave a data file containing trend data from a previous retrieval request intact. An unused index number is any that has not been part of a previous retrieval request and does not have data stored in a data file on the hard disk. Refer to ***Displaying Unused Archive Trend Indices*** in this section for the procedures to obtain a list of unused, available trend index numbers.

Displaying Unused Archive Trend Indices

Use the *Unused Archive Trend Indices* function to determine which trends have already been retrieved and reside in a file on the hard disk. This should be performed before making a retrieval request to prevent deleting any previously retrieved data.

Select *F Unused Archive Trend Indices* from the retrieve archived data menu. A page similar to the one shown in Figure 19-14 appears. The information is the archive index numbers that do not currently have data stored in a file on the hard disk.

PCU CONFIGURATIONS

PCU configuration archives are on a per module configuration basis. A retrieved PCU configuration can be used to verify or load the configuration of a module. PCU management functions also allow printing a retrieved configuration.

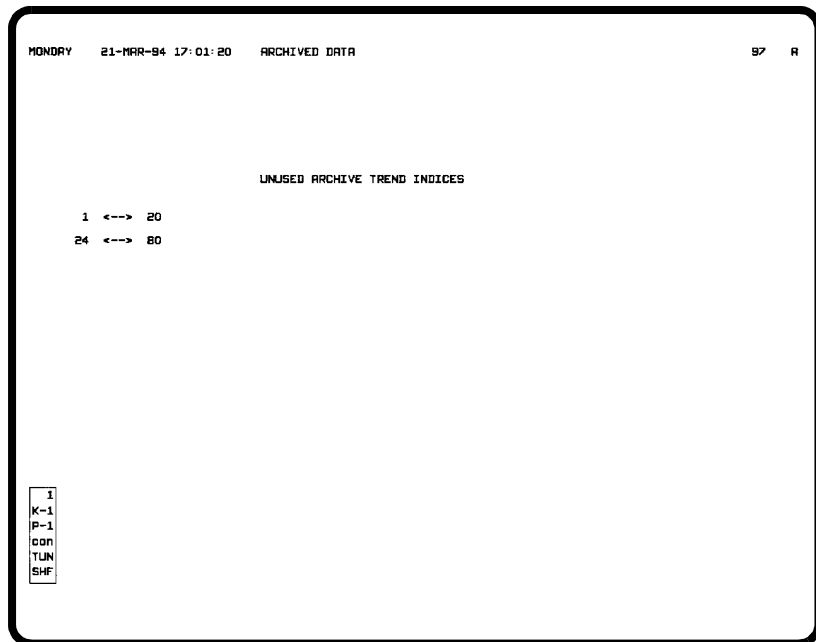

TPS0193B

Figure 19-14. Unused Archive Trend Indices Page

The archival retrieval function can retrieve either a single or range of stored configurations. Each PCU configuration request requires entering a time range and loop, PCU, and module address range. An archived PCU configuration must match or fall within **all** entered constraints to be retrieved.

Figure 19-15 shows the page used to retrieve PCU configurations, which appears after selecting *E Retrieve PCU Configuration* from the retrieve archived data menu. Table 19-6 explains each field of the retrieval page.

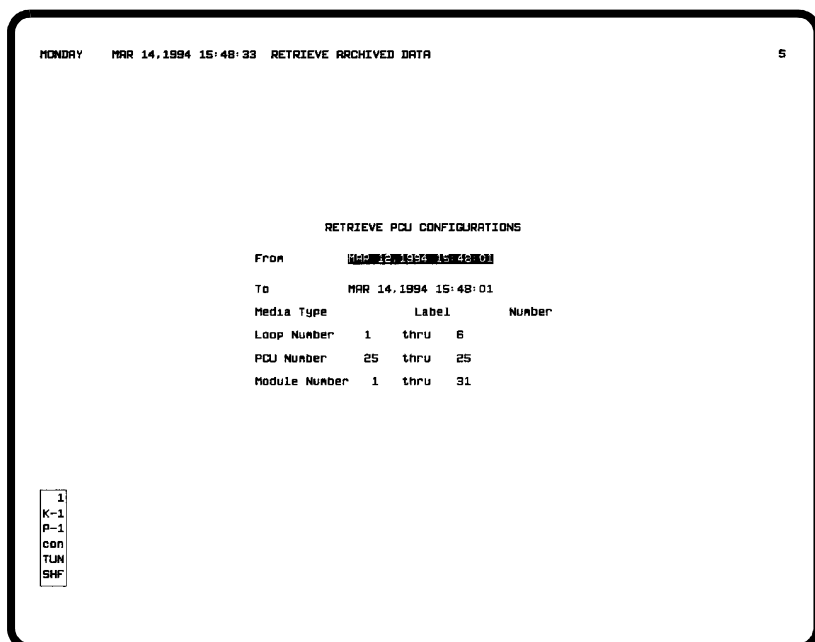

TPS0192B

Figure 19-15. Retrieve PCU Configurations Page

Table 19-6. PCU Configurations Retrieval Page Fields

Field	Description
From	Starting time and date from which to begin a search for PCU configurations.
To	Ending time and date at which to stop a search for PCU configurations.
Media type ¹	A valid media type is MAGTAPE or OPTICAL.
Label ¹	Volume name assigned to the PCU configurations data type during <i>Volume to Media Definition</i> .
Number ¹	Sequence number assigned to a volume of data when stored.
Loop number ___ thru ___	Range of loop addresses for which to search. A valid entry is from 1 to 250. Enter the same address in both fields to search for a single loop address.
PCU number ___ thru ___	Range of PCU addresses for which to search. A valid entry is from 1 to 250. Enter the same address in both fields to search for a single PCU address.
Module number ___ thru ___	Range of module addresses for which to search. A valid entry is from 0 to 31. Enter the same address in both fields to search for a single module address.

NOTE:

1. If retrieving from a medium archived to by another console, the media type, volume name, and sequence number are required. If retrieving from a medium that this console archived to, leave all three fields blank unless changes have been made to volume names since the original archiving.

Requesting a Directory of Retrieved Data

The *Directory of Retrieved Data* function can be used to view the contents of each archival retrieval directory. The function also allows deleting retrieved data files from the hard disk by deleting an entry from the directory listing.

Each data type has a separate selection on the directory of retrieved data menu page (Figure 19-16). To call this menu, first press **GENL FCTNS MENU**, then select the following menu items in the sequence shown.

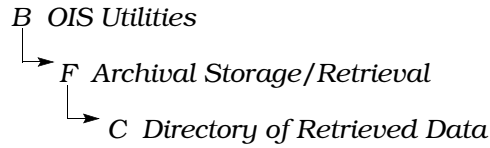

TAG DATA

A tag data directory listing appears after selecting *A Tag Data* from the retrieved data directory menu (Figure 19-17). Each entry in the directory shows the time range of data stored during a retrieval request, number of tag data files retrieved, and the amount of hard disk space the files occupy. The number of retrieved tag data files cannot exceed 240. The entries are arranged chronologically by the starting time. A maximum of 15 directory entries display per page. Press **NEXT PAGE** or **PREV PAGE** to view additional pages.

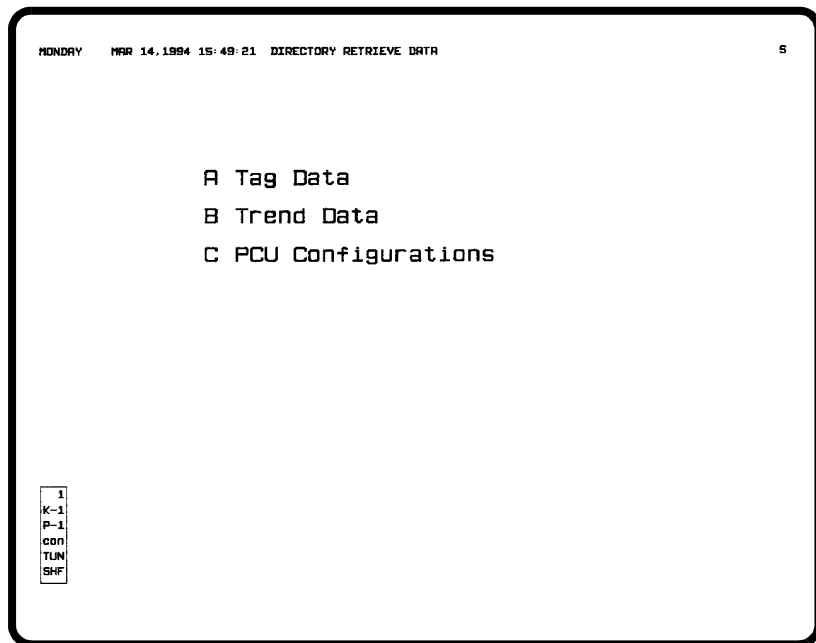

Figure 19-16. Directory of Retrieved Data Menu

TUESDAY 22-MAR-94 08:43:57 RETRIEVE ARCHIVED DATA R

DIRECTORY OF RETRIEVED TAGS

	FROM TIME	TO TIME	DESCRIPTOR DATA		SIZE (MB)
			FILES	FILES	
A	08:57:06 21-MAR-94	10:00:07 21-MAR-94	2	2	0.12
B	10:00:08 21-MAR-94	14:00:05 21-MAR-94	1	1	0.18
C					
D					
E					
F					
G					
H					
I					
J					
K					
L					
M					
N					
O					
			TOTALS	3 3	0.30 (MB)

1
 K-1
 P-1
 CON
 TLUN
 SHF

X Delete Selected Y Delete Page

TPS0195B

Figure 19-17. Directory of Retrieved Tags Page

TREND DATA

A trend data directory listing appears after selecting *B Trend Data* from the retrieved data directory menu (Figure 19-18). Each entry in the directory shows:

ARCHIVE TREND INDEX - corresponds to the trend retrieval list index number, not the index number assigned to the trend during its definition.

TAG NAME - name of the tag associated with the trended variable.

TAG SUBTYPE - CO, PV, RI, or SP appears if the trend is a STATION tag trend.

TREND MODE - collection mode as either sample, maximum, minimum, average, range, or sum.

FROM/TO - time span of the retrieval request.

RESOLUTION - resolution of the retrieved data as determined by the retrieval request. This can range from seconds to days.

The number of retrieved trend data files cannot exceed 80. The entries appear chronologically by index number. The trends that are retrieved depend on the trend retrieval list defined on the trend data retrieval page. A maximum of 15 directory

MONDAY 21-MAR-94 16:49:40 RETRIEVE ARCHIVED DATA S7 R

DIRECTORY OF RETRIEVED TRENDS

ARCHIVE TREND INDEX	TAG NAME	TAG SUB- TYPE	TREND MODE	FROM	TO	RESOLUTION
R 2	ANA-00009		SAMPLE	05:59:45 20-MAR-94	09:59:30 20-MAR-94	15 SECONDS
B 3	ANA-00015		SAMPLE	05:59:45 20-MAR-94	09:59:30 20-MAR-94	15 SECONDS
C 21	ANA-00003		SAMPLE	05:59:45 20-MAR-94	09:59:30 20-MAR-94	15 SECONDS
D 22	ANA-00004		SAMPLE	05:59:45 20-MAR-94	09:59:30 20-MAR-94	15 SECONDS
E 23	ANA-00005		SAMPLE	05:59:45 20-MAR-94	09:59:30 20-MAR-94	15 SECONDS
F						
G						
H						
I						
J						
K						
L						
M						
N						
O						

1
 K-1
 P-1
 con:
 TUN:
 SHF:

X Delete Selected Y Delete Page

TPS0196B

Figure 19-18. Directory of Retrieved Trends Page

entries display per page. Press **NEXT PAGE** or **PREV PAGE** to view additional pages.

PCU CONFIGURATIONS

A directory listing of retrieved PCU configurations appears after selecting **C PCU Configurations** from the retrieved data directory menu (Figure 19-19). Each retrieved configuration resides in a separate file. Each entry in the directory shows the loop, PCU, and module address of the configuration and a retrieval request time. Each entry is for a single file containing the configuration of a single module. Directory entries are in numerical order by address. A maximum of 15 directory entries display per page. Press **NEXT PAGE** or **PREV PAGE** to view additional pages.

DELETING RETRIEVED DATA FROM THE DIRECTORY PAGE

A directory page for each data type appears after selecting any directory option. The directory page has two options used to delete entries in the listing: *X Delete Selected* and *Y Delete Page*.

To select and delete individual data files:

1. Select *X Delete Selected*. The letters along the left edge of the page change to red. These letters are used to select files to delete.

MONDAY 21-MAR-94 17:09:27 RETRIEVE ARCHIVED DATA 97 A

DIRECTORY OF RETRIEVED PCU CONFIGURATIONS

LOOP	NODE	MODULE	TIME	FILE SIZE (KB)
A	2	B	5 14:00:04 21-MAR-94	0.75
B	2	B	12 14:00:04 21-MAR-94	4.50
C	2	B	18 18:00:27 21-MAR-94	1.75
D	2	B	21 18:00:27 21-MAR-94	1.50
E				
F				
G				
H				
I				
J				
K				
L				
M				
N				
O				
P				
Q				
R				
S				
T				
U				
V				
W				
X				
Y				
Z				
[
]				
{				
}				
~				
TOTAL SIZE ALL FILES				8.50 (KB)
X Delete Selected				Y Delete Page

1
K-1
P-1
con
TUN
SHF

TPS0197B

Figure 19-19. Directory of Retrieved PCU Configurations Page

2. Press a key corresponding to the selector letter adjacent to an entry to delete. The letter on the screen changes to green to identify an entry as being selected for deletion.
3. Select all desired entries to delete.
4. Press **ENTER**. All entries are removed from the list and corresponding retrieved data files are deleted.
5. Press **ESC** to exit delete mode.

Select *Y Delete Page* to delete all entries on the page. A prompt to confirm the deletion appears. All entries on the current page are removed from the list and the corresponding retrieved data files are deleted after confirming.

Viewing or Printing Retrieved Archive Data

In certain cases, other functions must be used to either print or view the retrieved data. Specifically, these include:

- Tag historian for further retrieval, then printing of tag data.
- Trend displays for viewing and custom logs for printing trend data.
- PCU management for viewing, printing, and restoring PCU configurations.

TAG DATA

The tag historian must be used to perform a second retrieval for tag data after transferring the data to the hard disk. Specifically, the tag historian retrieves individual or a group of tags from the files stored in the archival retrieval directory. When retrieving a group of tags, the retrieval is based on alarm group, tag historian group, or tag name. The tag historian function takes the desired data and stores it in another file in a dedicated tag historian directory. From there, the data can be printed using tag historian options.

Tag data can be retrieved from any console whether that console archived the data or not. When tag data stores for archiving, each tag contains both exception reported values or states and configuration data. This allows the data to be retrieved from any console even if database changes have been made.

TREND DATA

When panning to historical data on a trend display, any data collected from a PCU module and stored on the hard disk appears. The amount of trend data that remains on the hard disk depends on trend definition. After panning a trend display past this stored data, the console looks for additional trend data in an archival retrieval directory.

Use the pan options from a trend display to view retrieved trend data. Move the display presentation back in time to a time within the range of the retrieved data to view the data. Refer to **TREND CONTROL** in Section 14 for an explanation of panning.

PCU CONFIGURATIONS

PCU management allows printing retrieved PCU configurations. The configurations can also be used to verify an existing configuration or to download a configuration. Refer to **PCU Management Option** in Section 22 for an explanation and for the procedures.

Tag Historian

The *Tag Historian* option defines the data collected and stored by the console for tag data archiving. Functions available in the tag historian also provide the capability to recover data from a retrieved tag data file, then to print the data. Tag historian functions can be classified into two separate categories: Tag data storage and tag data retrieval.

NOTE: The tag historian does not support TEXTSTR tags.

The tag historian functions can be accessed by using the tag historian menu (Figure 19-20). To call this menu, first press **GENL FCTNS MENU**, then select the following menu items in the sequence shown.

```

B OIS Utilities
  |
  +-- J Tag Historian
  
```

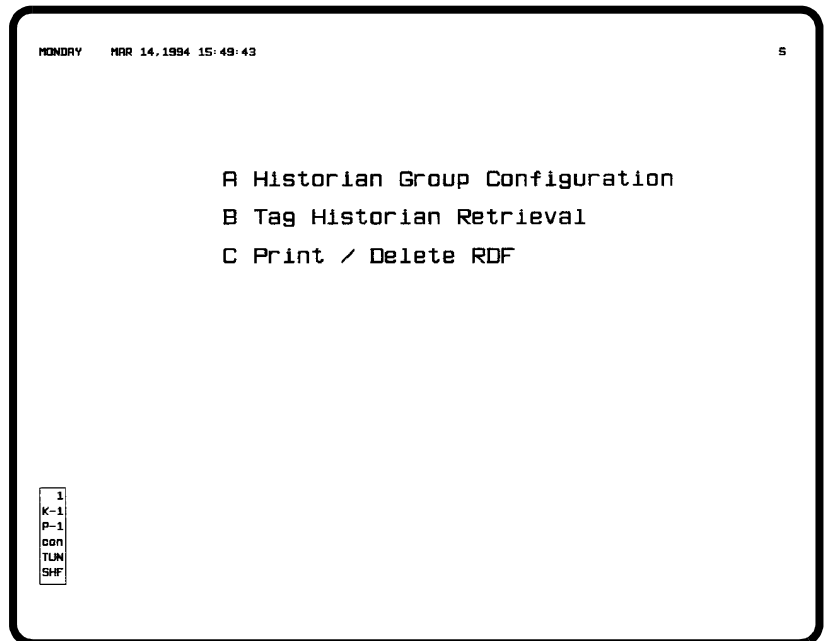

TPS0198B

Figure 19-20. Tag Historian Main Menu

Three different operations are performed with the tag historian menu:

Historian Group Configuration - determines the tag data that stores in the archival storage directory for eventual transfer to storage medium. Refer to **Setting Up Data to be Archived** in this section for further explanation and for the procedures.

Tag Historian Retrieval - creates a retrieved data file (RDF) containing tag information recovered from a retrieved tag data file. The retrieved tag data file resides in an archival retrieval directory and contains the data transferred back to the hard disk by using the *Retrieve Tags* function. Refer to **Retrieving Data by Type** in this section for additional explanation.

Print/Delete RDF - presents a directory listing of all RDF files and allows either printing information from these files or deleting the files.

To retrieve and print tag data:

1. Create an RDF file that contains tag data that was recovered from a retrieved tag data file. Select *Tag Historian Retrieval* options to recover the data and create the file. An RDF file resides in a dedicated tag historian directory. The data in the file can be identified by its name. These procedures are explained in the following sections.
2. Use the *Print/Delete RDF* option to view a directory listing of RDF files and to print data or delete data files.

REQUESTING A TAG HISTORIAN DATA RETRIEVAL

The *Tag Historian Retrieval* function provides the capability to recover data from retrieved tag data files residing in an archival retrieval directory. After using tag data retrieval procedures, this option must be selected to recover tag data. The archive data retrieval function retrieves data based on a time range. Data is recovered by searching the retrieved tag data files.

The result of this second retrieval is an RDF data file containing data for a single or range of tags. A maximum of 50 RDF files can be maintained. RDF files reside in a dedicated tag historian directory and are identified by a user-defined name. The information in these files depends on a time range and one of the following:

- Alarm group or alarm group range.
- Tag historian group.
- Tag name or wild card tag name.
- Defined list of up to 100 individual tags.

Select *B Tag Historian Retrieval* from the tag historian menu to call the menu used to set the constraints for data retrieval (Figure 19-21).

The menu page provides separate options to select the tag attributes for which to search. Constraints limit data retrieval to a specified time range and to specific tag attributes. Only data that matches or falls within the set constraint limits is retrieved.

Select any one of the options presented. Refer to ***Retrieve by Alarm Group***, ***Retrieve by Historian Group***, ***Retrieve by Tag Name***, or ***Retrieve by Tag List*** in this section for a detailed explanation of the constraints that determine the data to retrieve.

Use the *Directory of Retrieved Data* option accessed from archival storage and retrieval functions to determine the time span associated with retrieved tag data. Refer to ***Requesting a***

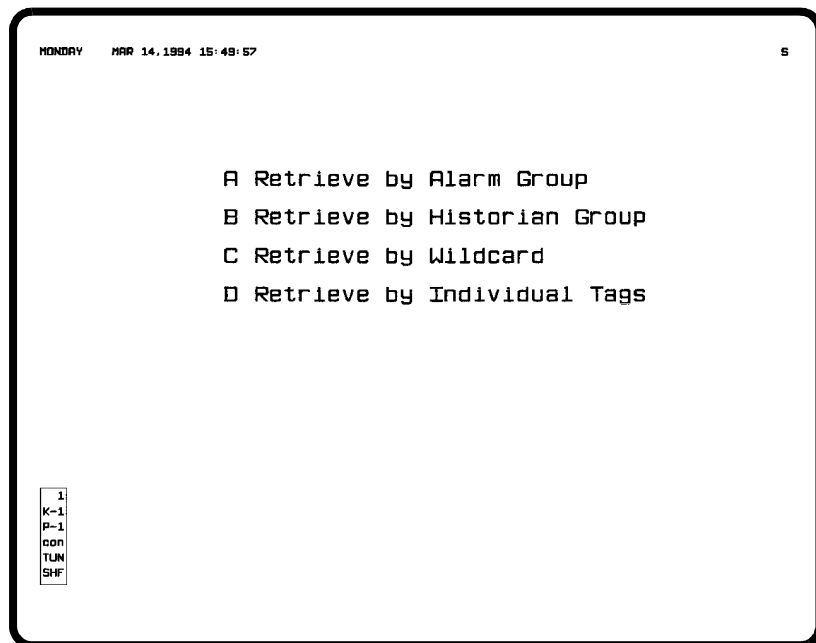

TPS0199B5

Figure 19-21. Tag Historian Retrieval Menu

Directory of Retrieved Data in this section for the procedures.

Retrieve by Alarm Group

Figure 19-22 shows the page that appears after selecting *A Retrieve by Alarm Group* from the tag historian retrieval menu. To retrieve tag data by alarm group:

1. In the *From* field, enter a starting time and date from which to begin a search for data.
2. Enter an ending time and date at which to stop a search for data in the *To* field.
3. Enter a name to be assigned to the RDF file in the *RDF Name* field. The name can be up to eight characters. After creating an RDF file, this name is used in other tag historian functions to identify the retrieved data.
4. Enter an alarm group range in:

Alarm Group __ to __

This limits any search to a specific set of tags identified by their alarm group. The field can identify either a single or range of alarm groups to retrieve. A valid entry is 1 to 99, or S. The complete alarm group range is from 1 to S. Enter the same

```

MONDAY  MAR 14, 1994 15:50:30  5

RETRIEVAL BY ALARM GROUP

From      MAR 12, 1994 15:50:01
To        MAR 14, 1994 15:50:01
RDF Name  TAG1
Alarm Group 1 to 15

1
K-1
P-1
con
TUN
SHF

```

TPS0200B

Figure 19-22. Retrieve by Alarm Group Page

alarm group number in both fields to designate a single alarm group.

NOTE: The retrieval operation initiated here can take a variable amount of time depending on the request and system load. The retrieval function runs as a background task. This allows exiting the page to perform other operations while a retrieval request is being processed.

5. Press **ENTER** to initiate a retrieval request. Do **not** press **ENTER** until all fields have been defined. Retrieval takes several minutes to complete. Press **ESC** at any time before pressing **ENTER** to exit the page without initiating a retrieval request.

If all inputs are valid, the request is processed. If not, the input cursor positions on the field in error. The operator information events page provides informational messages to indicate the current status of the retrieval request. The *Print/Delete RDF* option n also provides retrieval request status information.

Retrieve by Historian Group

Figure 19-23 shows the page that appears after selecting *B Retrieve by Historian Group* from the tag historian retrieval menu. To retrieve tag data by historian group:

1. In the *From* field, enter a starting time and date from which to begin a search for data.

```

MONDAY MAR 14, 1994 15:50:59 5
RETRIEVAL BY HISTORIAN GROUP

From MAR 14, 1994 15:50:59
To MAR 14, 1994 15:50:36
RDF Name TAG1
Tag Historian Group 10

1
K-1
P-1
can
TUN
SHF

```

TPS0201B

Figure 19-23. Retrieve by Historian Group Page

2. Enter an ending time and date at which to stop a search for data in the *To* field.
3. Enter a name to be assigned to the RDF file in the *RDF Name* field. The name can be up to eight characters. After creating an RDF file, this name is used in other tag historian functions to identify the retrieved data.
4. Enter a tag historian group search constraint in the *Tag Historian Group* field. This limits any search to a specific set of tags defined in a historian group. A valid entry is from 1 to 10 and must be of a defined group.

NOTE: The retrieval operation initiated here can take a variable amount of time depending on the request and system load. The retrieval function runs as a background task. This allows exiting the page to perform other operations while a retrieval request is being processed.

5. Press **ENTER** to initiate a retrieval request. Do **not** press **ENTER** until all fields have been defined. Retrieval takes several minutes to complete. Press **ESC** at any time before pressing **ENTER** to exit the page without initiating a retrieval request.

If all inputs are valid, the request is processed. If not, the input cursor positions on the field in error. The operator information events page provides informational messages to indicate the current status of the retrieval request. The *Print/Delete RDF* option also provides retrieval request status information.

Retrieve by Tag Name

Figure 19-24 shows the page that appears after selecting *C Retrieve by Wildcard* from the tag historian retrieval menu. To retrieve tag data by tag name:

1. In the *From* field, enter a starting time and date from which to begin a search for data.

```

MONDAY MAR 14, 1994 15:52:09 5
RETRIEVAL BY TAG WILDCARD

From      MARCH 13, 1994 15:00:00
To        MAR 14, 1994 15:00:00
RDF Name  TAG1
Wildcard Pattern ANR*

1
K-1
P-1
con
TUN
SHF
TPS0202B

```

Figure 19-24. Retrieve by Tag Wild Card Page

2. Enter an ending time and date at which to stop a search for data in the *To* field.
3. Enter a name to be assigned to the RDF file in the *RDF Name* field. The name can be up to eight characters. After creating an RDF file, this name is used in other tag historian functions to identify the retrieved data.
4. Enter a tag name search constraint in the *Wildcard Pattern* field. This limits any search to only those tags whose name matches either a specific or wild card tag name. The wild cards are the asterisk (*) or question mark (?) characters.

The * represents multiple characters, the ? a single character. For example, ABC*XYZ retrieves any tags beginning with ABC and ending with XYZ with any number of characters in between. ABC?XYZ retrieves any tags beginning with ABC and ending with XYZ and only one character in between. The

system supports multiple occurrences of ?. Multiple occurrences of * are treated as ? after the first *.

NOTE: The retrieval operation initiated here can take a variable amount of time depending on the request and system load. The retrieval function runs as a background task. This allows exiting the page to perform other operations while a retrieval request is being processed.

5. Press **ENTER** to initiate a retrieval request. Do **not** press **ENTER** until all fields have been defined. Retrieval takes several minutes to complete. Press **ESC** at any time before pressing **ENTER** to exit the page without initiating a retrieval request.

If all inputs are valid, the request is processed. If not, the input cursor positions on the field in error. The operator information events page provides informational messages to indicate the status of the retrieval request. The *Print/Delete RDF* option also provides retrieval request status information.

Retrieve by Tag List

Figure 19-25 shows the page that appears after selecting *D Retrieve by Individual Tags* from the tag historian retrieval menu. This option allows specifying a list of up to 100 individual tags to retrieve. The page presents a menu of three options at the bottom of the window.

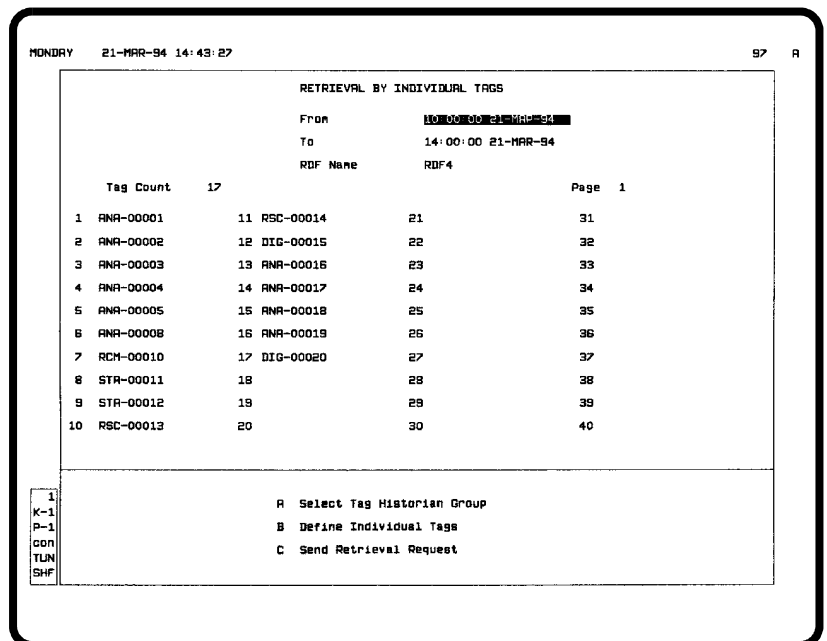

TPS0203C

Figure 19-25. Retrieve by Individual Tags Page

The steps required to initiate a tag list retrieval are:

1. Define the list using either option *A* or *B*.
2. Select the *C Send Retrieval Request* option to initiate the retrieval request. This option should be selected after completely defining the list.

The complete list of 100 individual tags spans three separate pages. Press **NEXT PAGE** or **PREV PAGE** to view the complete tag list. The *Page* field updates to show the number of the currently displayed page.

Tag Historian Group

The *A Select Tag Historian Group* option defines a list of tags to retrieve by specifying a tag historian group. All tags defined in the selected group initially make up the list of tags to retrieve. The list can be modified, however, by adding or deleting tag names from the list before initiating the retrieval request. To create a list of tags with the option, then initiate a retrieval of the tags:

1. Press **A** to select the option. An *Enter Tag Historian Group Number* field appears.
2. Enter a tag historian group number from 1 to 10.
3. Press **ENTER**. The tag list is then filled in with tag names from the specified group. The group number entered must be of a defined group or the page remains blank. After entering, an input cursor appears on the *From* field.

Press **ESC** at any time to cancel any edits.

4. In the *From* field, enter a starting time and date from which to begin a search for data.
5. Enter an ending time and date at which to stop a search for data in the *To* field.
6. Enter a name to be assigned to the RDF file in the *RDF Name* field. The name can be up to eight characters. After creating an RDF file, this name is used in other tag historian functions to identify the retrieved data.
7. If desired, move the cursor to the tag definition area to modify the list of tags. Continue with the next step if modifications are not required.

To remove or redefine a tag in the list, move to the name of that tag and either press **CLEAR** or enter a new name or index number. Move to an available, undefined tag definition field and enter a tag name or index number to add an additional tag. The *Tag Count* field updates as tags are removed or added.

8. Press **ENTER** to save any edits made and to return control to the menu at the bottom of the page.

NOTE: The retrieval operation initiated here can take a variable amount of time depending on the request and system load. The retrieval function runs as a background task. This allows exiting the page to perform other operations while a retrieval request is being processed.

9. Select *C Send Retrieval Request* to initiate the retrieval. The message *Retrieval Request Queued* appears to verify the action.

Press **ESC** to leave the list defined without initiating a retrieval request. This must be performed, however, before selecting option *C*.

Individual Tags

The *B Define Individual Tags* option defines a list of tags by individual tag name or index number entry. This option provides an empty tag retrieval list to define individual tags. To create a list of tags with the option, then initiate a retrieval of the tags:

1. Press **B** to select the option. An input cursor initially appears on the *From* field. Press **ESC** at any time to abort any edits.

2. In the *From* field, enter a starting time and date from which to begin a search for data.

3. Enter an ending time and date at which to stop a search for data in the *To* field.

4. Enter a name to be assigned to the RDF file in the *RDF Name* field. The name can be up to eight characters. After creating an RDF file, this name is used in other tag historian functions to identify the retrieved data.

5. Move the cursor to the tag definition area to define the list of tags to retrieve. Move to an available, undefined tag definition field and enter a tag name or index number to add a tag. Continue to enter tags until the list of tags is complete. The *Tag Count* field updates as tags are added.

6. When complete, press **ENTER** to save any edits made and to return control to the menu at the bottom of the page.

NOTE: The retrieval operation initiated here can take a variable amount of time depending on the request and system load. The retrieval function runs as a background task. This allows exiting the page to perform other operations while a retrieval request is being processed.

7. Select *C Send Retrieval Request* to initiate the retrieval. The message *Retrieval Request Queued* appears to verify the action.

Press **ESC** to leave the list defined without initiating a retrieval request. This must be performed, however, before selecting option C.

If all inputs are valid, the request is processed. If not, the input cursor positions on the field in error. The operator information events page provides informational messages to indicate the status of the retrieval request. The *Print/Delete RDF* option also provides retrieval request status information.

PRINTING OR DELETING RETRIEVED TAG DATA

The *Print/Delete RDF* option provides the capability to print the data in a selected RDF file. The option also provides the capability to delete or abort processing of RDF files. Three types of information from each RDF file can be printed in any combination:

Retrieval request data - identifies the retrieval criteria defined with the alarm group, tag historian group, wild card, or individual tags retrieval options. This data relates to the retrieval constraints defined during data retrieval.

Tag configuration data - provides database information as defined for a tag during configuration. The information consists of both general and specific tag related attributes.

Exception reports - details the values or states exception reported for the process variable referenced by the tag. The information includes tag name, tag type, tag value or state, engineering unit of measurement, quality, alarm state, and date and time of the exception reported data.

A data printout or deletion is initiated by using options of the RDF print/display page (Figure 19-26). Select *C Print/Delete RDF* from the tag historian menu to call the page. The page provides a directory of RDF files. Each entry in the list reflects the status of a previous retrieval request.

RDF Name - name assigned to retrieved data on one of the retrieval request pages.

Time From - starting time of a retrieval request.

Time To - ending time of a retrieval request.

Status - current processing status of a retrieval, print, or delete request for a selected RDF file. The status can appear as:

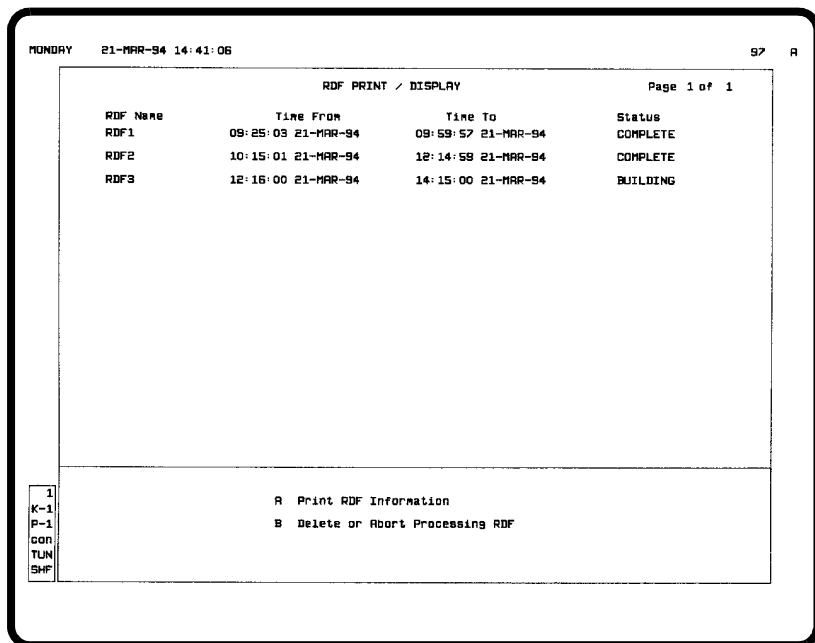

TPS0204B

Figure 19-26. Print/Delete RDF Page

COMPLETE - no current processing.

FORMATTING - formatting a requested print.

BUILDING - building an RDF file after a retrieval request.

DELETING - deleting an RDF file after a delete request.

ABORTING - aborting the current retrieval or print request.

ABORT/DEL - aborting the current retrieval or print request and deleting an RDF file.

The options at the bottom of the page provide the ability to print or delete RDF file data and to abort any retrieval or print processing currently in progress. These options are explained in the following sections.

Printing RDF Tag Data

Data contained in RDF files and the type of data to print can be selected by using the *Print RDF Information* option (Figure 19-26). To print tag data in an RDF file:

1. Press **A** to select the option. A *Select RDF Name to Print* field appears and selector letters appear adjacent to the *RDF Name* column.

2. Press **NEXT PAGE** or **PREV PAGE** to call the next or previous page of up to 13 additional RDF file names. This is only required if the desired RDF file to print is not currently on the page. Continue with the next step after finding the desired RDF name.

NOTE: A print operation initiated here can take a variable amount of time depending on the amount of data to format and system load. The tag historian print function runs as a background task. This allows exiting the page to perform other operations while a print request is being processed.

3. Select an RDF file to print by selecting the letter to the left of the file name. A menu with data type options appears at the bottom of the page (Figure 19-27). The menu provides the capability to select the type of information to retrieve and print from the selected RDF file. Press **ESC** to deselect the RDF file and make another selection.

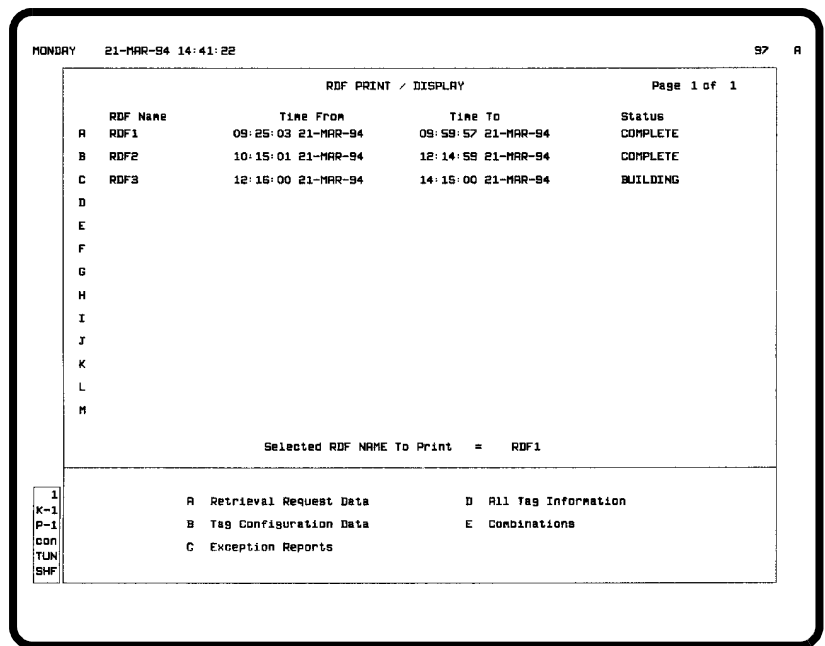

TPS0205B

Figure 19-27. Print RDF Tag Data Options Page

4. Select one of the options from the menu:

- A** - to print only retrieval request data.
- B** - to print only configuration data.
- C** - to print only exception reported data.
- D** - to print all data in the RDF file.

[E] - to select a combination of the three data types. This option requires input before the print request is processed.

Retrieval Request Data(Y/N) ___
 Tag Configuration Data(Y/N) ___
 Exception Reports(Y/N) ___

Enter **YES** to print the type of data. Enter **NO** to not print. Press **[ENTER]** to initiate the request.

5. Press **[ESC]** to exit the page.

The status of a print request for an RDF file can be seen in the *Status* column for that RDF file. The column shows *FORMATTING* while processing a print request.

Figure 19-28 is an example of an RDF file printout. The example shows the data that prints when selecting the *All Tag Information* option.

```

RDF#: TAGDAT                                OCT 15,1992 07:27:58 - OCT 26,1992 10:26:37                                Page 1

                                JOB SUMMARY
RETRIEVAL OPERATION STARTED AT DEC 05,1992 10:11:51
COMPLETED AT DEC 05,1992 10:14:50
NO ERRORS ENCOUNTERED

                                REQUEST CRITERIA
DATA REQUESTED FROM : JUL 27,1992 15:00:00 TO NOV 01,1992 00:00:00
RETRIEVAL CRITERIA : ALARM GROUP 1 TO 5

                                TAG CONFIGURATION DATA
RCM-00215      Tag Index - 215      Tag Descriptor - SOE1 ISM STANDARD REPORT
               Tag Type - RCM      Loop PCU Mod Block - 2 5 9 200
               Alarm Group - 5
               Alarm Comment -
               Zero State - ZERO      One State - ZERO
               Configuration Time - OCT 14,1992 13:02:16
RCM-00216      Tag Index - 216      Tag Descriptor - SOE2 ISM SUMMARY REPORT
               Tag Type - RCM      Loop PCU Mod Block - 2 5 9 201
               Alarm Group - 5
               Alarm Comment -
               Zero State - ZERO      One State - ZERO
               Configuration Time - OCT 14,1992 13:02:16
RCM-00217      Tag Index - 217      Tag Descriptor - SOE3 ISM PRE-FAULT REPORT
               Tag Type - RCM      Loop PCU Mod Block - 2 5 9 202
               Alarm Group - 5
               Alarm Comment -
               Zero State - ZERO      One State - ZERO
               Configuration Time - OCT 14,1992 13:02:17
RCM-00218      Tag Index - 218      Tag Descriptor - SOE4 ISM POST FAULT REPORT
               Tag Type - RCM      Loop PCU Mod Block - 2 5 9 203
               Alarm Group - 5
               Alarm Comment -
               Zero State - ZERO      One State - ZERO
               Configuration Time - OCT 14,1992 13:02:17

                                EXCEPTION REPORT DATA
TAG NAME      TAG TYPE      TAG VAL/STATE      ENG. UNIT      QUALITY      ALARM STATE      TIME
RCM-00215      RCM      ZERO      *      *      *      OCT 15,1992 07:27:58
               RCM      ZERO      *      *      *      OCT 15,1992 08:23:07
               RCM      ZERO      *      *      *      OCT 15,1992 09:18:19
               RCM      ZERO      *      *      *      OCT 15,1992 10:13:35
               RCM      ZERO      *      *      *      OCT 15,1992 11:05:24
               RCM      ZERO      *      *      *      OCT 15,1992 12:03:05
               RCM      ZERO      *      *      *      OCT 15,1992 12:57:46
               RCM      ZERO      *      *      *      OCT 15,1992 13:52:33
               RCM      ZERO      *      *      *      OCT 15,1992 14:47:13
               RCM      ZERO      *      *      *      OCT 15,1992 15:42:00
    
```

Figure 19-28. Example Retrieved Tag Data Printout

Delete or Abort RDF Tag Data Processing

An RDF tag data file can be deleted or processing can be aborted by using the *Delete or Abort Processing RDF* option (Figure 19-26). To delete or abort processing of an RDF file:

1. Press **B** to select the option. A *Select RDF to Delete/Abort* field appears and selector letters appear adjacent to the *RDF Name* column.
2. At this point, press **NEXT PAGE** or **PREV PAGE** to call the next or previous page of up to 13 additional RDF file names. This is only required if the desired RDF file to delete or abort is not currently on the page.
3. Select an RDF file to delete by selecting the letter to the left of the file name. Press **ESC** to deselect the RDF file and make another selection.
4. One of two things happens depending on the current processing status for the selected RDF file: Either an *Are You Sure?* prompt appears or a new menu appears at the bottom of the page.

Prompt If the RDF file status is *COMPLETE* or *BUILDING*, the *Are You Sure?* prompt appears.

Menu If the RDF file status is *FORMATTING*, the following options appear:

A Abort Processing and Delete RDF
Stops processing and deletes the RDF file.

B Abort Processing
Stops processing only.

If the *Are You Sure?* prompt appears, go to the next step. If the menu appears, select either *A* or *B*.

5. Enter **YES** in response to the *Are You Sure?* to continue with the request; enter **NO** to cancel.
6. Press **ENTER**.

The status changes to *DELETING* after confirming a delete request. It changes to *ABORT/DEL* after confirming an abort processing and delete RDF request. It changes to *ABORTING* after an abort request.

On the next call-up of the *Print/Delete RDF* page, the status should return to *COMPLETE* or a deleted RDF file should not appear as an entry in the directory listing.

SECTION 20 - UTILITIES

INTRODUCTION

This section explains the following utilities available on the console:

- Set date and time.
- Cancel queued print requests.

SET DATE AND TIME

The *Set Date and Time* option provides system and local time maintenance capabilities. It performs two functions:

1. Sets the local displayed time for the console. This determines the date and time for data collected and recorded by functions such as logging and archiving.
2. Establishes a system time to synchronize all nodes on the loop.

PCU modules use a system date and time for functions that provide a time-stamp along with collected data, for example, trend data. System date and time refers to the date and time that is set for the communication highway and available to all nodes on the loop.

After the time is set, an offset is calculated to properly display any times associated with collected data. The calculated offset is either added to or subtracted from the system time to calculate the local time for a piece of data. This is done to present the time in displays and printed reports in local time.

NOTE: In the following discussions, any reference to time implies date and time.

System and Local Time

For the INFI-NET system, the system time is normally set to Greenwich Mean Time (GMT). It can, however, be set to any time that is common to the entire system. In either case, some type of absolute time is required to properly initialize console time synchronizing variables and offsets. By using GMT time as an absolute time and setting the system time to this time for all system sites, it becomes possible to transfer data that is time-stamped between different sites even if the sites are in different time zones. The time of occurrence in local time can be derived from the system time associated with a piece of data. This is automatically performed by the console to show all times in local time.

The Plant Loop system does not use an absolute time. The system time on the loop is always the local time or the time entered as the local time. A console that operates on Plant Loop system, however, still needs an absolute time that it uses internally.

Time Synchronization

Only one node on the communication highway controls time synchronization for all nodes connected to the loop. That node is the time-sync master. Specifically, the communications interface unit of a single node provides a time-sync message that synchronizes the communication modules of other nodes. For the INFI-NET system, the message establishes a common system time and local time on the loop. The time-sync message establishes a local time on the loop for the Plant Loop system.

The console can become the time-sync master on a loop. Normally, a console becomes the master when the *Set Date and Time* function is used. If there is more than one console in the system, the consoles perform an arbitration process to establish a time-sync master. Since some external clocks are considered more accurate than others, this allows the console with the most accurate external clock to assume the responsibility of maintaining system time. An external clock, for example, is a battery-backed clock.

Table 20-1 lists console clock accuracies. Other nodes are capable of synchronizing the loop. Refer to the product instruction for a node for its clock accuracy rating.

Table 20-1. Console Clock Accuracy Ratings

Rating	Console	Software Release
12	MCS (or MFP interface) with satellite clock	All
10	40 series with IIMCP02 ¹ module (INFI-NET)	H and later
	IIOIS25 with IIMCP02 ¹ module (INFI-NET)	G and later
	MCS PLUS with IIMCP02 ¹ module (INFI-NET)	V and later
9	IIOIS20	All
6	40 series with IIMCP01 module (Plant Loop)	All
	IIOIS25 with IIMCP01 module (Plant Loop)	All
	IIOIS25 with IIMCP02 module (INFI-NET)	E and earlier
	MCS PLUS with IIMCP02 module (INFI-NET)	S and earlier
	MCS PLUS with INPCI02 interface (Plant Loop)	All
6	MCS PLUS with INICI01 interface (INFI-NET)	All
	MCS without satellite clock	All

NOTE:

1. SCSI mode only.

For the INFI-NET system, it is suggested that only one console be used to set date and time, preferably the console with the most accurate external clock. After initially setting the system time on this console, the time then only needs to be accepted on the remaining consoles on the loop. An option is provided to accept the system time and local time from the loop without making any changes to them. Using this method prevents the consoles from having to perform the arbitration process, which begins each time the system time (GMT time) or local time (wall-clock) is set from a console.

Since the local time is the system time for the Plant Loop system, the local time must be set on each console in the system to establish time synchronization. After this initial setting, however, the time can be adjusted for all consoles from a single console. Control of time synchronization transfers as the time is set on each console. The consoles perform the arbitration process to return control to the console with the most accurate external clock. In this case, it may be better to set the time for the console with the most accurate external clock last.

The first page of the INFI-NET diagnostics function identifies the current time-sync master for the loop. Refer to **INFI-NET DIAGNOSTICS** in Section 21 for further explanation.

After the time-sync master has been established either by setting the time or by arbitration, a console maintains the system time through its communication interface unit. The interface unit sends a set time command on the loop every two minutes for INFI-NET system and 30 minutes for Plant Loop system to maintain the system time. To insure that the interface has an accurate time, the console that is the time-sync master initiates a set time command to its communication interface unit at least once every half hour. The console sets the time for its battery-backed clock to GMT time (or the common time established for the system if not using GMT time as the absolute time).

For the INFI-NET system, a time-sync message contains both the system time and the local time. When a console that is not the time-sync master accepts a time-sync message, it synchronizes its local displayed time to the local time received in the message. It sets its battery-backed clock to the system time received.

For the Plant Loop system, a time-sync message contains only a system time, which is also the local time. When a console that is not the time-sync master accepts a time-sync message, it calculates the time it sets in its battery-backed clock as an offset from the local time received in the message. This is done because the console still needs some type of absolute time to properly initialize its time synchronizing variables and offsets.

Important Considerations

Caution should be taken when initially setting system time (GMT time) for the INFI-NET system. Trend data collection for a console with software release C.n or earlier and a management command system (MCS or MCS PLUS) console with software release Q.n or earlier operating on the same loop as a console with software release E.1 or later and an MCS or MCS PLUS console with software release R.1 or later can be affected by this change. In this case, perform the following steps:

1. On each C.n or later console or Q.n or later console, archive any trend data already collected before setting GMT time if it is important to retain this information. The archived data can be retrieved at any time.
2. Set GMT time for the system.
3. Delete the **TRNDHDR.TR** file from the [DATA.USN14] directory on each console.
4. Reset the console or OIS application.

Caution should also be taken when using this function to change the system time for the loop. If the date or time is radically changed, existing trend data will be reinitialized causing trend data loss. A change could create gaps in collected trend data. Normal time changes such as going to daylight savings time do not cause any loss of trend data.

Setting the Date and Time

Use the *Set Date and Time* option to access the time maintenance functions. Figure 20-1 shows the display used. To call this display, first press **GENL FCTNS MENU**, then select the following menu items in the sequence shown.

```
B OIS Utilities
  |
  |→ B Set Date and Time
```

The set date and time page provides several time maintenance options. Which option to use depends on the current time-sync status of the system. Options A, B, C, and E adjust the local time (wall-clock). Options E and F change the system time (absolute time). The function of option D depends on the type of communication highway on which the console operates.

For the INFI-NET system, option D accepts the current local time and system time of the loop for this console. This allows initializing the local time and system time for the console

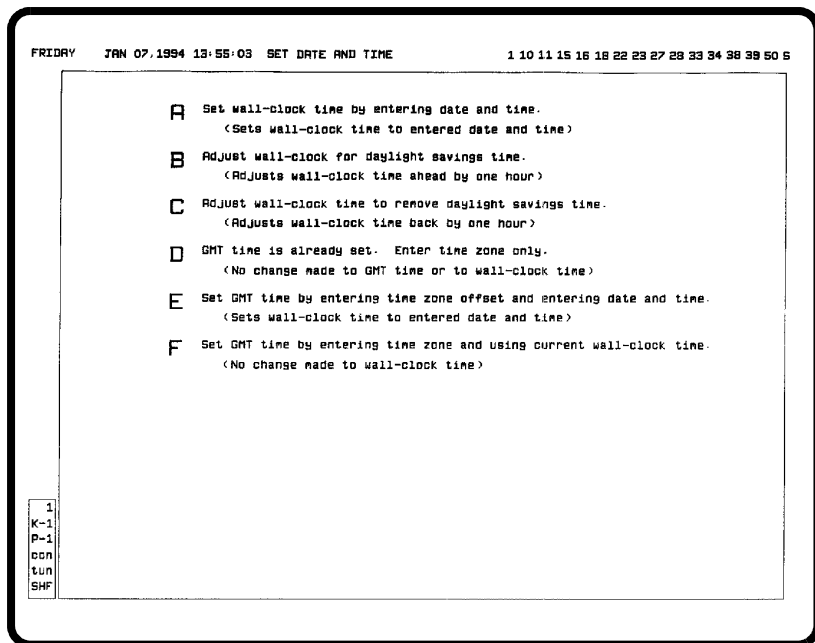

TPS0770B

Figure 20-1. Set Date and Time Page

without affecting the current local time and system time already established on the loop.

For the Plant Loop system, option *D* allows entering a start and end date and a time for daylight savings. The console requires this information to properly calculate an offset from the local time to set the time for its battery-backed clock if using daylight savings times.

To set the date and time:

1. Choose the appropriate time maintenance option for your requirements. The page that appears next depends on the option chosen.
2. Make all required entries. Refer to **INFI-NET Date and Time** or **Plant Loop Date and Time** in this section for information about the various *Set Date and Time* options.

When entering an hour, minute, and second offset, indicate whether the offset is a positive or negative offset value in the first position of the *HOUR* entry, for example, **-05** or **+01**.

3. Press **ENTER** to initiate the time change.

The time maintenance options work differently for a Plant Loop system and an INFI-NET system.

INFI-NET Date and Time

When setting the time for an INFI-NET system, it is important to remember that the time-sync message sent on the loop contains both the system time and the local time. The system time should be set to some common time such as GMT time. This common time does not have to be Greenwich Mean Time, although it is suggested. The common time can be, for example, the time at some main site to which all remote sites are to synchronize. In any case, this common time must be propagated to all other systems that are to share data. The local time, in most cases, should be the local time according to the time zone in which the system operates. Refer to **System and Local Time** in this section for further explanation.

TIME MAINTENANCE OPTIONS**NOTES:**

1. In the *Set Date and Time* options, *GMT* can also be interpreted as absolute time if Greenwich Mean Time is not being used.
2. When entering an hour, minute, and second offset, indicate whether the offset is a positive or negative offset value in the first position of the *HOUR* entry, for example, **-05** or **+01**.

- Option A** *A Set wall-clock time by entering date and time* - sets or adjusts the local time on the consoles. This option updates the local time being sent to all other consoles on the loop without affecting the system time. This function directly sets the local time for the consoles to the date and time entered as the *Wall-Clock Date and Time*.
- Option B** *B Adjust wall-clock for daylight savings time* - advances the local time for the consoles by one hour.
- Option C** *C Adjust wall-clock time to remove daylight savings time* - retards the local time for the consoles by one hour.
- Option D** *D GMT time is already set. Enter time zone only* - enters a time zone offset from GMT time in hours, minutes, and seconds. The entry is strictly for reference and simply allows entering the value so it does not have to be calculated or looked up repeatedly. The importance of the option is that it initializes time synchronization for a console without affecting the system time or local time previously set.
- Option E** *E Set GMT time by entering time zone offset and entering date and time* - sets the system time to GMT time and sets the local time. This function directly sets the local time for the consoles to the date and time entered as the *Wall-Clock Date and Time*. It sets the system time based on a time zone offset from the current local time.

entered local time + *Time Zone Offset from Greenwich Mean Time* = system time

The *Time Zone Offset from Greenwich Mean Time* entry determines the amount of offset.

The *Daylight Savings Time Effective* field identifies whether the local time being entered is or is not a daylight savings time. This allows the console to adjust system time accordingly. Enter **YES** if the time is a daylight savings time, **NO** if not.

Option F *F Set GMT time by entering time zone and using current wall-clock time* - sets the system time to GMT time without affecting the current local time. This sets the system time based on a time zone offset from the current local time. Option A must be used to set the local time first.

local time set with option A + *Time Zone Offset from Greenwich Mean Time* = system time

The *Time Zone Offset from Greenwich Mean Time* entry determines the amount of offset.

The *Daylight Savings Time Effective* field identifies whether the current local time is or is not a daylight savings time. This allows the console to adjust the system time accordingly. Enter **YES** if the time is a daylight savings time, **NO** if not.

DATE AND TIME REQUIREMENTS

For a system having only one console operating on an INFI-NET system, set GMT time and local time (wall-clock) on the console. This establishes time synchronization for the entire loop.

For a system having more than one console operating on an INFI-NET system, setting GMT time (or some absolute time) from only one console is required to set the system time for the entire loop. It is suggested that a single console be designated for setting the system time. Even though the system time has been set for the loop, the loop time must still be accepted on each other console. This is required to establish the relationship between local time and system time and to properly initialize console time synchronizing variables and offsets. If this is not performed, the following message appears as an operator request for action:

GREENWICH MEAN TIME MUST BE INITIALIZED

The message can be cleared after using option D. Refer to **OPERATOR ACTION REQUESTS** in Section 17 for the procedures to process the action request.

The suggested sequence for initially establishing time synchronization for the loop and consoles is:

1. Set the initial system time (GMT time or some absolute time) and the local time on one console. Choose option *E* or *F* to initially set the system time for the loop. Option *E* also sets the local time for the consoles. If using option *F*, the local time must first be set with option *A*. Choose the best option for your particular requirements.

Option *E* can also be used to initialize time-syncing, but this option either causes this console to become the time-sync master or starts the arbitration process to determine the time-sync master based on clock accuracy rating (Table 20-1).

2. Initialize time synchronization on all other consoles:
 - a. Select *Set Date and Time*.
 - b. Choose option *D*. This will not affect the system time set previously.
 - c. Process the operator action request.

After initially establishing time synchronization, the local time can be adjusted at any time. Choose option *A*, *B*, or *C* to adjust the local time only for this and all other consoles on the loop. Use the console with the most accurate external clock to make any time adjustments (Table 20-1).

EXAMPLE INFI-NET TIME SETTING

A single INFI-NET loop spans three global sites: Cleveland, Los Angeles, and London. To have the Los Angeles and London sites synchronize to the Cleveland site, set the time for each site as shown in Table 20-2.

Table 20-2. INFI-NET Time Set Example (Site Synchronization)

City	Local Time	Time Zone Offset	Resulting System Time
Cleveland	5:00 A.M.	00	5:00 A.M.
Los Angeles	2:00 A.M.	-03	
London	10:00 A.M.	+05	

To have all sites synchronize to Greenwich Mean Time, set the time for each site as shown in Table 20-3.

Option *E* or options *A* and *F* would be used to set the local time and system time.

Table 20-3. INFI-NET Time Set Example (GMT Synchronization)

City	Local Time	Time Zone Offset	Resulting System Time
Cleveland	5:00 A.M.	-05	10:00 A.M.
Los Angeles	2:00 A.M.	-08	
London	10:00 A.M.	00	

Plant Loop Date and Time

When setting the time for a Plant Loop system, it is important to remember that the time-sync message sent on the loop contains only a system time, which in this case is also the local time. A console still requires some type of absolute time such as GMT time to properly initialize its time synchronizing variables and offsets. This absolute time is used internally by the console. The system time, in most cases, should be the local time according to the time zone in which the system operates. Refer to **System and Local Time** in this section for further explanation.

TIME MAINTENANCE OPTIONS

NOTES:

1. In the *Set Date and Time* options, GMT can be interpreted as the absolute time.
2. When entering an hour, minute, and second offset, indicate whether the offset is a positive or negative offset value in the first position of the *HOUR* entry, for example, **-05** or **+01**.

- Option A** *A Set wall-clock time by entering date and time - sets or adjusts the system time on the consoles. This option updates the system time being sent to all other consoles on the loop without affecting the absolute time for the console. This function directly sets the system time for the consoles to the date and time entered as the Wall-Clock Date and Time.*
- Option B** *B Adjust wall-clock for daylight savings time - advances the system time on the consoles by one hour.*
- Option C** *C Adjust wall-clock time to remove daylight savings time - retards the system time on the consoles by one hour.*
- Option D** *D Configure beginning and end of daylight savings time - identifies the dates and times for daylight savings time. The console requires this to properly set its battery-backed clock.*

The *Daylight savings time used* field determines whether or not daylight savings time is being used for the system. Enter **YES** in the field if the system uses daylight savings time, then enter a starting and ending date and time for daylight savings time. The entry in the *YEAR* field must match for both the start and

end date. If not, the entries will not be accepted. This must be performed once a year.

The field defaults to *NO*, and if it is not changed to *YES*, no further action is required now or at any time in the future.

Option E *E Set GMT time by entering time zone offset and entering date and time* - sets the absolute time used by the console to GMT time and sets the system time on the loop. This function directly sets the system time for the consoles to the date and time entered as the *Wall-Clock Date and Time*. It sets the absolute time based on a time zone offset from the current system time.

entered system time + *Time Zone Offset from Greenwich Mean Time* = absolute time

The *Time Zone Offset from Greenwich Mean Time* entry determines the amount of offset.

The *Daylight Savings Time Effective* field identifies whether the system time being entered is or is not a daylight savings time. This allows the console to adjust absolute time accordingly. Enter **YES** if the time is a daylight savings time, **NO** if not.

Option F *F Set GMT time by entering time zone and using current wall-clock time* - sets the absolute time used by the console without affecting the current system time on the loop. Option *A* must be used to set the system time first. This sets the absolute time based on a time zone offset from the current system time.

system time set with option *A* + *Time Zone Offset from Greenwich Mean Time* = absolute time

The *Time Zone Offset from Greenwich Mean Time* entry determines the amount of offset.

The *Daylight Savings Time Effective* field identifies whether the current system time is or is not a daylight savings time. This allows the console to adjust the absolute time accordingly. Enter **YES** if the time is a daylight savings time, **NO** if not.

DATE AND TIME REQUIREMENTS

For a system having only one console operating on a Plant Loop system, set GMT time and local time (wall-clock) on the console. Setting the local time establishes a system time for time synchronization of the loop. Setting GMT time initializes internal time synchronization for the console.

For a system having more than one console operating on a Plant Loop system, GMT time must be set on each console.

This is required to properly initialize console time synchronizing variables and offsets. If this is not performed, the following message appears as an operator request for action on each console for which the time has not been set:

GREENWICH MEAN TIME MUST BE INITIALIZED

The message can be cleared after using option *E*. Refer to **OPERATOR ACTION REQUESTS** in Section 17 for the procedures to process the action request.

The sequence for setting the time at each console is:

1. Set the local time and GMT time. Choose option *E* or *F* to initially set the local time and establish an absolute time (as GMT time or some other common time) for the console. If using option *F*, the local time must first be set with option *A*. Choose the best option for your particular requirements. Using any one of these options causes this console to become the time-sync master or starts the arbitration process to determine the time-sync master based on clock accuracy rating (Table 20-1).

Even though the time-sync message sent on the Plant Loop system does not contain an absolute time, the console still internally requires an absolute time to calculate any offsets.

2. Choose option *D* to identify the dates and times for daylight savings. This is required to properly set the battery-backed clock. This must be performed once a year.

3. Process the operator action request.

After initially setting the time on each console, the local time can be adjusted at any time from one console. Choose option *A*, *B*, or *C* to adjust the local time only for this and all other consoles on the loop. Use the console with the most accurate external clock to make any time adjustments (Table 20-1).

CANCELING QUEUED PRINT JOBS

A *Cancel Print* option gives the ability to cancel a pending print job. It also provides a directory listing of currently queued print jobs. Any of the following types of print jobs can be canceled:

- Periodic print of the events log or operator actions log.
- Periodic print of the alarm summary report.
- Directory of an archive volume.
- Events retrieved from an archive volume.
- Log image retrieved from an archive volume.
- Tag summary.
- Tag or trend list printout.

TUESDAY AUG 02, 1994 11:01:38 CANCEL QUEUED PRINT 1 2 3 4 5 6 7 8 9 10 11 12 13 14 15 16 17 18 27 28 9 A
33 34 38

DIRECTORY OF QUEUED PRINTS

PRINTER NUMBER	FILE NAME	FILE SIZE (KB)	FILE CONTENTS
R 1	32100000.PT	6	Tag or Trend Summary
B 1	IND36F80.19	6	Infi-Net Diagnostics Summary
C 1	32105805.PT	142	Tag or Trend Summary
D 2	32100000.PT	6	Tag or Trend Summary
E			
F			
G			
H			
I			
J			
K			
L			
M			
N			
O			

1
K-3
P-1
don
tun
SHF
RLT

X Cancel Selected Y Cancel Page

TPS0771B

Figure 20-2. Directory of Queued Prints Page

3. Press **ENTER** to initiate the cancel and clear the job from the directory listing. Press **ESC** before pressing **ENTER** to abort the cancellation request.

To cancel all queued print jobs:

1. Press **Y** to select the *Cancel Page* option.
2. Press **ENTER** to initiate the cancel and clear all print jobs from the directory listing. Press **ESC** before pressing **ENTER** to abort the cancellation request.

SECTION 21 - SYSTEM DIAGNOSTICS

INTRODUCTION

This section explains the console functions used to monitor the INFI 90 OPEN system status. The ability to monitor the following operating status is provided:

- Nodes and modules in the INFI 90 OPEN system. Any node connected to the communication highway reports its status. In general, the modules that report status include communication and control modules.
- The communication highway that connects the individual system nodes for communication.

These abilities allow the console to be a central platform that can be used to diagnose system problems ranging from plant communications failures to individual module problems.

Alarm indications are given for INFI 90 OPEN module status errors. Status pages provide the ability to acknowledge these alarms and to display the status reports for individual modules. The status pages can also be viewed for those modules not in an error condition. This section explains how to call up the status pages. It also details the information presented and the procedures to acknowledge alarms from these pages.

SYSTEM STATUS DISPLAYS

INFI 90 OPEN node and module status are received in exception reports. Status exception reports are received for each node or PCU module that has a defined N90STA tag. Each exception report contains at a minimum the module error status (either an error exists or no errors), mode, and module type. Other information in these reports is specific to the type of module reporting its status. Refer to the discussion on tag configuration in the **Configuration** instruction for a list of node and module types from which status reports can be received (Table 1-2 lists instruction numbers).

Status display templates are provided that can be used to build displays that communicate node and PCU module status. This section explains INFI 90 OPEN diagnostics using displays created from these standard templates. Either displays created from these templates or user-created status displays that provide the same types of information can be incorporated into process operations.

The provided templates contain all the necessary display elements to access and to show status information such as:

- Node and module type.
- Node error indications.
- Module operating mode.
- Module status bytes.
- Module problem reports.

Before a template can be used in operations, however, it must be modified to include index numbers of N90STA tags for which the display is to present status information. The same type of information can also be incorporated into a user-created status display.

Calling the Status Display

When an N90STA tag is defined, it is automatically assigned to the system (S) alarm group. Anytime an N90STA defined node or module goes off-line or into an error condition, the S indicator appears at the title line by default. Other indications may occur depending on the alarm group configuration. The indication notifies that a problem exists in the INFI 90 OPEN system. One option available to determine the problem is to view the status pages.

The console provided displays use a three-level hierarchy to communicate equipment status. The hierarchy follows a sequence that starts from a loop overview level and ends with the module status bytes and problem reports for a specific module. Normally, the highest level display is assigned to **SYSTEM STATUS SUMM** for single key access to status reports. After the initial display is on the screen, selections made within that and each subsequent page sequence to the desired status level. A status display can also be called by using the *Display by Name* option, or the display can be assigned to a keyboard function key and annunciator display panel push-button.

The operating parameters page called for an N90STA tag also provides status information. The operating parameters page provides an option for calling a module problem report page directly. The problem report page provides the most detailed view of the exception reported status information.

System Status Hierarchy

The hierarchy levels of the provided status displays are:

System level - overviews the operational status of INFI 90 OPEN equipment on a communication highway. This page shows both normal and error conditions.

Node level - reviews the status of each module within a node selected from the system level page. This page also shows both normal and error conditions.

Module level - details the status of a single module selected from the node level page. It monitors and displays the status bytes and problem reports for a single module.

System Status Overview Page

The system status overview page provides status information for nodes. The nodes that appear in the list depend on the N90STA tags assigned to the display during its creation. This is normally the highest level display.

Figure 21-1 shows the standard system status overview page. The display source file for this display is the **N90STAT1.DT** file. This file provides an empty display template that must be modified to include the N90STA tags for which the display is to show status. The page uses **NODLINE.DT** symbol files to define each node and its related attributes that appear in the list.

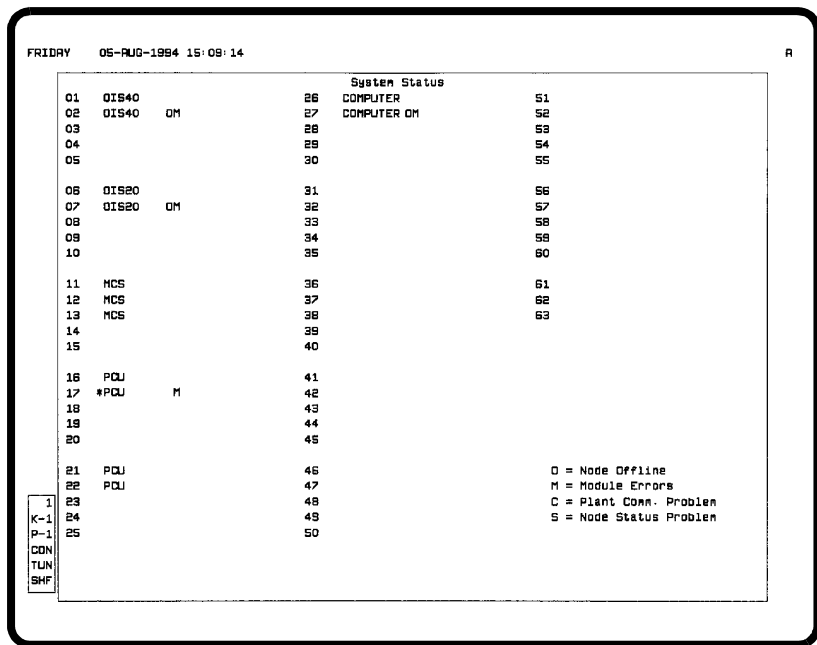

TPS0080B

Figure 21-1. System Status Overview Page

Node Selector

The numbers 01 through 63 are selectors for calling the next level status page for a node in the list. Normally, each number corresponds to a loop address of a node, although this is not a requirement.

Node Type A node type appears next to each node selector. The nomenclature that appears depends on the tag definition. For proper indications, each N90STA tag in the list must define a node rather than a module.

The page is driven by the module type given in a module status exception report. It will display nomenclatures denoting devices and groups of devices rather than specifying the full nomenclature of each module in the group. For example, the three modules of the INICI01 interface (two INNIS01 modules and one INIIT01 module) will be shown as *SSB/IIL*. Table 21-1 lists the node type descriptors.

Table 21-1. Node Type Descriptors

Type	Description
CIU/PC11	Plant Loop to computer interface
CIU/PC12	
CIU/IC11	INFI-NET to computer interface
COMPUTER	Engineering workstation
IIR	INFI-NET to INFI-NET remote interface
INVALID	Invalid node type
IPL	INFI-NET to Plant Loop local interface
IPR	INFI-NET to Plant Loop remote interface
MCS	Management command system (MCS or MCS PLUS) console
OIS10	Operator interface station
OIS20	
OIS40	
OIU	Operator interface unit console
OIU5000	
PCU	Process control unit
PIM	Process interface module
PPG/PPR	Plant Loop to Plant Loop remote interface
SIG12	Signature console
SIG42	
SIG43	
SOE	Sequence of events
SSB/IIL	INFI-NET to INFI-NET local interface

A yellow asterisk (*) appears if a module type configured in the database does not match a module type received in an exception report. The indication appears when a module of the node has the configuration error. The indicator displays to the left of the node type. This error causes an alarm.

Error Indicators Up to four different indicators can appear for a node in error. Each indicator identifies a different type of error. Each type of error triggers an alarm.

O - node off-line; no exception reports are received from off-line nodes and from modules within the node.

M - module errors; at least one module within the node is in error. The *M* also appears if any module in a node is not in **execute** mode.

C - plant communication problem; the communication module for the node is in error. Each node has communication modules to interface with the communication highway. A communication problem exists when one of these modules has a problem related to its transmit or receive capabilities or it has some internal error.

S - node status problem; the node is having power problems. A node having a system status error reports this condition through its interface unit. The actual problem may be caused by a faulty power supply or fan, for example.

Key in a node selector number or use a touch point to access a node status summary page for a node in the list. For example, press **1-3** for node number 13. The node status summary page can be called for any node whether it is in a normal or error condition. Refer to **Node Status Summary Page** in this section for a description of the information presented on the next page.

Node Status Summary Page

The node status summary page provides status information for a single node. Which node information is presented for depends on the node selection made from the system status overview page. The node status summary page shows the type and operating mode for individual modules within a given node. A general error indication also appears to identify any modules in error.

The specific modules that appear in a node summary depend on the N90STA tag assigned to the display during its creation. To present information for each node selected from the system status overview page, a separate node summary display must be created for each node listed on the page.

Figure 21-2 is the standard node status summary page. The display source file for this display is the **NODSTAXX.DT** file. This file provides an empty display template that must be modified to include the N90STA tag for which it is to show status. The template uses a **MODLINE.DT** symbol file to define each module and its related attributes that appear in the list.

A second template file (*ENODSTXX.DT*) is provided that can also be modified to create a node status overview page. The template uses an *ENODLINE.DT* symbol file to define each module that appears in the list. This symbol file provides enhanced module type descriptions.

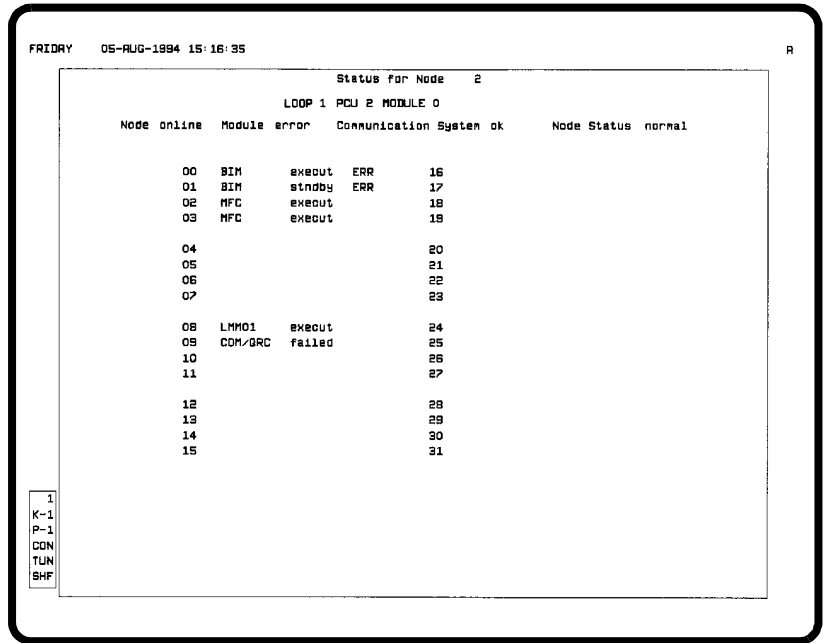

TPS0077B

Figure 21-2. Node Status Summary Page

Node Number The *Status for Node* field identifies the number of the node that was selected from the system status overview page.

Node Address The *LOOP*, *PCU*, and *MODULE* fields show the address of the selected node.

Node Status Several fields at the top of the page repeat the information that was previously shown on the system status overview page. The fields and their purpose are:

Node - displays as *offline* or *online*.

Module - displays as *error* or *ok*.

Communication System - appears as *error* or *ok*.

Node Status - appears as *problem* or *normal*.

Module Selector The numbers 00 through 31 are selectors for calling the next level status page for a module in the list. Normally, these numbers are also the module address, although this is not a requirement. The number also does not necessarily reflect the physical location of a module within a cabinet.

Module Type A module type appears next to each module selector, which appears as either a full or an abbreviated nomenclature. For proper indications, each N90STA tag in the list must define a module.

The page is driven by the module type given in a module status exception report. Table 21-2 lists the module type descriptors that appear when using the **MODLINE.DT** source file, which incorporates standard module type escape commands (**ea 67,32** or **ed 67,32**). Table 21-3 lists the module type descriptors that appear when using the **EMODLINE.DT** source file, which incorporates enhanced module type escape commands (**ea 67,71** or **ed 67,71**).

Table 21-2. Module Type Descriptors

Type	Description
AMMH	Analog master module (NAMM01)
AMML	Analog master module (IMAMM03)
AOM	Analog output module
BIM	Bus interface module
BTM	Bus transfer module
CBC	Batch command controller
CLC	Loop command controller
COM/QRC	Controller module and quick response controller module
CSC	Sequence command controller
CTM	Configuration and tuning module
CTT	Configuration and tuning terminal
GCM/PPT	Plant Loop to Plant Loop transfer module (remote)
IIT01	INFI-NET to INFI-NET transfer module (local)
IIT02	INFI-NET to INFI-NET transfer module (remote)
IPT01	INFI-NET to Plant Loop transfer module (local)
IPT02	INFI-NET to Plant Loop transfer module (remote)
LCM01	Large controller module
LCM02	
LCM03	
LMM01	Logic master module
LMM02	
LSM/PCT	Plant Loop to computer transfer module
MFC	Multi-function controller module
MFP	Multi-function processor module
MPC	Multi-processing module
NPM	Network processing module (Controlway)
PBUG	Module bus debugger
PIM	Processor input module (interface unit for OIU console)
PTM	Point table module

Table 21-2. Module Type Descriptors (continued)

Type	Description
SBM	Superloop bus module
SCM	Serial communication module (network interface unit)
SEM	Sequence of events module
SSM/ICT	INFI-NET to computer transfer module

Table 21-3. Enhanced Module Type Descriptors

Type	Description
AMM	Analog master module (IMAMM02/03)
BIM	Bus interface module
CBC	Batch command controller
CLC	Loop command controller
COM	Controller module
CSC	Sequence command controller
CTT	Configuration and tuning terminal
GCM/PPT	Plant Loop to Plant Loop transfer module (remote)
ICT/M01	INFI-NET to computer transfer module
ICT/M02	INFI-NET multibus communications processor
IMAOM01	Analog output module
IMLMM02	Logic master module
IMMFP01	Multi-function processor module
IMMFP02	
IMMFP03	
IMMPC01	Multi-processing module
INBTM01	Bus transfer module
INICT01	INFI-NET to computer transfer module
INIIT01	INFI-NET to INFI-NET transfer module (local)
INIIT02	INFI-NET to INFI-NET transfer module (remote)
INIPT01	INFI-NET to Plant Loop transfer module (local)
INIPT02	INFI-NET to Plant Loop transfer module (remote)
INNPM01	Network processing module (Controlway)
INPTM01	Point table module
INSEM01	Sequence of events module
LSM/PCT	Plant Loop to computer transfer module (interface unit for MCS or MCS PLUS console and 5,000-tag OIU console) Plant Loop multibus communications processor
MFC	Multi-function controller module
NAMM01	Analog master module
NCTM01	Configuration and tuning module
NLCM01	Large controller module
NLCM02	
NLCM03	

Table 21-3. Enhanced Module Type Descriptors (continued)

Type	Description
NLMM01	Logic master module
NNIU01	Network interface unit
NPIM01	Processor input module
NSBM01	Superloop bus module
PBUG01	Module bus debugger

A yellow asterisk (*) appears if a module type configured in the database does not match a module type received in an exception report. The indicator displays to the left of the module type. This error causes an alarm.

Module Mode

The current operating mode for each module in the list appears next to the module type.

execut - on-line and in execute mode.

config - on-line and in configure mode.

error - on-line and in error mode. Generally, this indication occurs when a module configuration error exists.

stndby - appears for a backup or redundant module. The mode of the backup module is the same as the primary module unless the primary fails and the backup assumes the responsibilities of the primary.

failed - off-line or some internal problem exists.

Error Indicator

An *ERR* indication is given for each module that is in error.

Key in a module selector number or use a touch point to access a module status summary page for a module in the list. For example, press **1-3** for module number 13. The module status summary page can be called for any module whether it is in a normal or error condition. Refer to **Module Status Summary Page** in this section for a description of the information presented on the next page.

Press **BACK** to return to the system status overview page.

Module Status Summary Page

The module status summary page provides status information for a single module. Which module information is presented for depends on the module selection made from the node status summary page. The page provides both the status bytes and module problem reports for a selected module. When the module status summary page is called, both a read module status and read module problem report message are initiated.

The selected module then replies with the requested information. Figure 21-3 is the standard module status summary page.

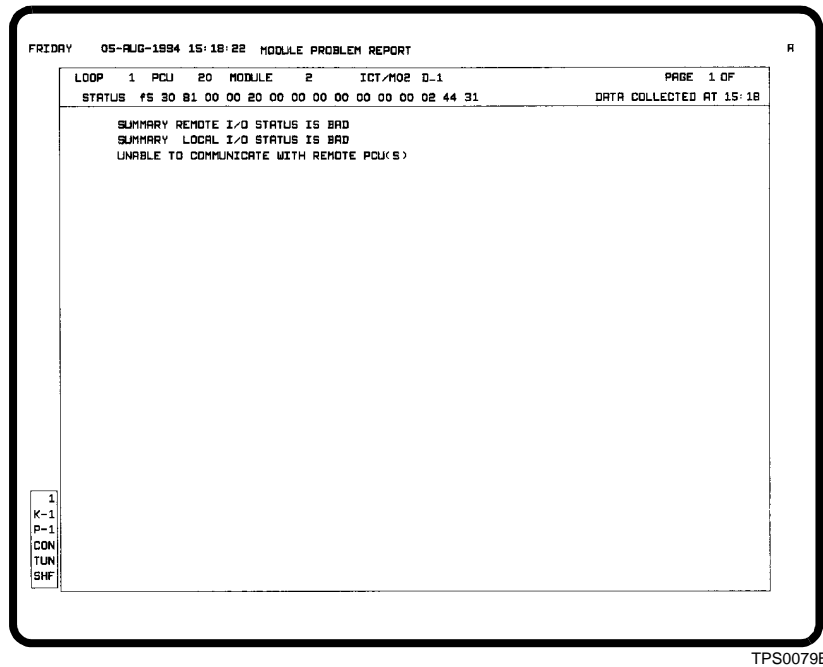

Figure 21-3. Module Status Summary Page

The summary page has two sections. The information at the top of the page is status information and the section below the status information lists the module problem reports.

- Address** The *LOOP*, *PCU*, and *MODULE* fields show the address of the selected module.
- Type** The field next to the address shows the exception reported module type, which appears as either a full or an abbreviated nomenclature.
- Revision** Along with the type, a field shows the module revision level. A revision level may or may not appear for a module. If the module is capable of reporting its revision level, the console will present the appropriate level. An *N/A* appears for any module that does not report revision level.
- Page** The *PAGE n OF n* fields indicate the current page on display and the total number of pages used to present problem report information. The field updates as each problem report page is viewed.
- Status Bytes** The *STATUS* field presents the module status bytes reported by a module. Depending on the module type, the number of bytes a module returns ranges from five to 16 bytes. Each byte is a

hexadecimal value. Refer to the product instruction for a specific type of module to interpret the status byte presentation.

Time The *DATA COLLECTED AT* field shows the time at which the status and problem report was read. The time updates if an update is requested while viewing the page.

Problem Reports Each problem report is descriptive text that summarizes a problem or error. Problem reports for a module may span several pages.

Press **NEXT PAGE** or **PREV PAGE** to view additional pages. Press **NEXT PAGE** while viewing the last page of module problem reports to cause another snapshot of the reports to be read from the module. This also returns to the first page of the new report.

Press **BACK** to return to the node status summary page.

MODULE STATUS BYTES

As stated previously, the number of status bytes that display depends on the type of module selected. A particular module may report from five to 16 bytes. If any of these bytes do not apply for a given module, they are set to zero to show a good status. Of these bytes, the first two are common for most types of modules. The remaining bytes are specific to a particular module. Each byte is a hexadecimal value.

Table 21-4 details the information presented in bytes one and two. Convert the hexadecimal value to a binary value then refer to Table 21-4 to interpret the status bytes. For example, f5 converts to 11110101.

Table 21-4. Module Status Bytes

Byte	Bit							
	7	6	5	4	3	2	1	0
1	ES	MODE		TYPE				
2	FTX	BAC	RIO	LIO	CFG	NVF	NVI	DSS

The terms and acronyms are defined as:

ES - error summary: 0 = ok, 1 = error exists. If there is an error indicated in the status information, the bit is set to one.

MODE - module mode: 00 = configure, 01 = failed, 10 = error, 11 = execute.

TYPE - module type. Each INFI 90 OPEN module has a different type identifier. The module status summary page provides a module type field that references these bits.

FTX - first time in execute mode: 0 = no, 1 = yes.

BAC - backup status: 0 = ok, 1 = bad.

RIO - summary of remote input status: 0 = ok, 1 = bad.

LIO - summary of local input status: 0 = ok, 1 = bad.

CFG - on-line configuration changes being made: 0 = no, 1 = yes.

NVF - nonvolatile memory failure: 0 = no, 1 = yes.

NVI - nonvolatile memory initialized: 0 = no, 1 = yes.

DSS - station status: 0 = ok, 1 = bad.

MODULE PROBLEM REPORTS

A module problem report message details information on the status of a module. The report provides the same type of data that is presented in module status bytes, but provides a higher level of detail. The problem reports cover a wide range of system problems. Descriptive text is associated with each reported problem.

Depending on the type of report, the returned information can identify, for example, the actual station, remote module, or local module and the address of a function block within the module causing an error. The information will also identify I/O modules in error and the type of error condition for that module.

Acknowledging System Status Alarms

A system (S) alarm can be acknowledged from a status summary page in the normal way. Both the system status overview and node status summary pages provide alarm indications.

All normal (good) status indications appear in green on system status pages. Any errors for a node or module appear in yellow. An error being reported by a node or module causes a system status alarm. All normal alarm indications are given for these types of alarms. Since the pages do not use an alarm status field, the fields that indicate a status error flash instead when an alarm has not been acknowledged.

Normally, a remote I/O error or local I/O error is indicated with a system status alarm. A *System Status I/O Error Filter* field on the general parameters page gives the option to prevent these types of module errors from causing a system status alarm. If the option is enabled, any remote I/O error or

local I/O error is filtered out and is not treated as a status alarm.

Two choices are available for acknowledging alarms on the system status overview and node status summary pages: Individually or entire page. Press **PAGE ACK** to acknowledge all alarms on a page. To acknowledge a single alarm:

1. Press **ACK ALARM**. This positions a cross hair (+) alarm cursor on the first error indication.
2. Press either **TAB** or **TAB BACK** to position the cursor on a specific error field.
3. Press **ACK ALARM** to acknowledge that alarm. The field stops flashing after being acknowledged.
4. After all acknowledgments are complete, press **CANCEL** then **CURSOR** to clear the alarm cursor from the page.

Acknowledging a node status alarm on the system status overview page acknowledges all related module alarms on the node status summary page for that node. Acknowledging all alarms on the node status summary page acknowledges the related node status alarm on the system status overview page. Leaving at least one alarm unacknowledged on the node status summary page causes the node status alarm on the system status overview page to remain unacknowledged.

MODULE FIRMWARE REVISION DISPLAY

The module firmware revision display shows a list of modules within a given node and the mode and revision level for each module. The display gives the capability to both print and display this information. An N90STA tag must be defined for both the node and individual modules within that node to appear on this display. To call the firmware revision display:

1. Press **MISC MENU**.
2. Press **C** to select the *Display by Name* option. A *Display Name* field appears.
3. Enter **FIRMWARE**, then press **ENTER**.

The display can also be assigned to and called by pressing an assignable function key or annunciator display panel push-button.

Figure 21-4 is an example of the module firmware revision display after a node has been selected. The display initially appears blank with only the options presented at the bottom of

the page. The display source file for this display is the **FIRMWARE.DT** display file.

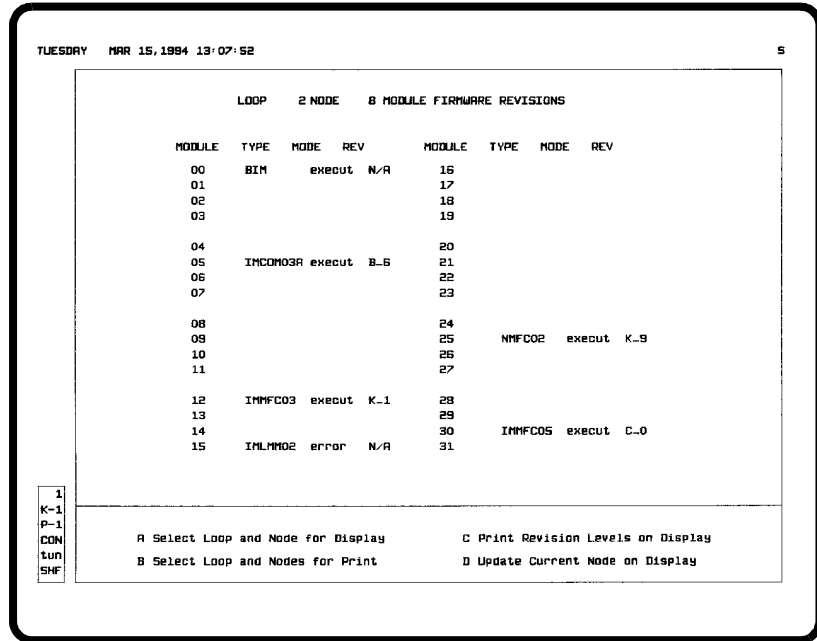

TPS0078B

Figure 21-4. Module Firmware Revision Display

Display Attributes

The attributes that appear on the module firmware revision display are for each module within a selected node.

Address The numbers 00 through 31 under the *MODULE* heading correspond to the Controlway or module bus address of each control or communication module within the node. This does not necessarily reflect their physical position within a cabinet.

Type The *TYPE* column indicates the type of module, which appears as either the full nomenclature or an abbreviated nomenclature.

If a communication error occurs, it is shown in the *TYPE* column in the format *Ennn*, where *nnn* is an error code integer number. Refer to the **Hardware** instruction for a list and description of these CIU/NIU error codes (Table 1-2 lists instruction numbers).

Mode The *MODE* column indicates the current operating mode for the module.

execut - on-line and in execute mode.

config - on-line and in configure mode.

error - on-line and in error mode. Generally, this indication occurs when a module configuration error exists.

failed - some type of failure, possibly an internal error.

NOTE: If a module is off-line, it will not appear in the list.

Revision Level The *REV* column shows the module firmware revision level. Not all modules are capable of reporting revision level. The type of module and its revision level determine whether the console can display a revision level for that module. If a module is not capable of reporting its revision level, the display shows *N/A* in the *REV* column.

A plus sign (+) indicator is shown after the revision level if the module firmware is newer than the information in the **MODULE.RV** file. This file resides in the [DATA.USN02] directory. The function uses information from the file to translate a revision level received in an exception report to an ASCII character string.

Operations

In some cases, a module must be in either execute or configure mode to report its status. A fixed function block in the module is read to acquire the revision level. Other modules report revision level as part of their module status exception report while in any of their on-line modes.

MODULE REVISION LEVELS

Table 21-5 identifies which INFI 90 OPEN modules can and cannot report their firmware revision levels. The revision levels for modules with levels equal to or greater than those listed in the availability column can be displayed.

Table 21-5. Module Revision Level Availability

Module Type	Availability
IMAOM01, NAOM01	Not available
NAMM01	Not available
NAMM02	Available with revision E.0
NAMM02A	Available with revision A.0
IMAMM03, NAMM03	Available with revision A.0
NCOM02	Not available
NCOM02A	Not available
NCOM02B	Not available
IMCOM03, NCOM03	Not available
IMCOM03A, NCOM03A	Available with revision B.0
IMCOM04, NCOM04	Not available
IMCOM04A, NCOM04A	Available with revision A.0
IMQRC01, NQRC01	Not available
IMQRC01A, NQRC01A	Available with revision B.0

Table 21-5. Module Revision Level Availability (continued)

Module Type	Availability
NLMM01 NLMM01A IMLMM02, NLMM02	Available with revision F.1 Available with revision A.0 Available with revision A.0
NMFC01 NMFC02 IMMFC03, NMFC03 IMMFC04, NMFC04 IMMFC05, NMFC05 IMMFP01 IMMFP02 IMMFP03 IMMPC01, NMPC01	Available with revision D.0 Available with revision B.0 Available with revision B.0 Available with revision A.0 Available with revision A.0 Available ¹ Available ¹ Available ¹ Available with revision F.0
CBC01 CSC01 CLC01 CLC02 CLC03 CLC04	Available with revision A.0 Available with revision A.0 Available with revision B.0 Available with revision A.0 Available with revision C.0 Available with revision C.0
INBIM02, NBIM01/02 INICT01, NSSM01 INIIT01, NBCM01 INIIT02, NGCM03 INIPT01, NGCM04 INNPM01 INSEM01 NSBM01 NSCM01	Not available Available ¹ Available ¹ Available ¹ Available ¹ Available ¹ Available ¹ Available ¹ Available ¹
IIMCP01 IIMCP02	Available ¹ Available ¹
NPIM01	Not available
NCTM01	Not available
PBUG01	Available ¹

NOTE:

1. Revision level reported in module status exception report.

OPTIONS

The options at the bottom of the page allow selecting and either displaying or printing revision levels for modules in a node. The valid loop and node ranges for all options are:

Plant loop system - loop defaults to 0. The only required entry is a node number from 1 to 63.

INFI-NET system - loop range is from 0 to 250; node range is from 1 to 250.

For the print options, a printout occurs at the printer assigned to the window. Look at the keyboard status block of the page to determine which printer. All printed information is the same

format as what is seen on the screen except that a time of collection appears on the printout.

Select Loop and Node for Display - displays the revision information for a single node.

1. Press **A** to select the option. The following prompt appears:

LOOP ___ NODE ___

2. Enter a loop number in the *LOOP* field.
3. Enter a node number in the *NODE* field.
4. Press **ENTER**.

Select Loop and Nodes for Print - prints the revision information for a single or range of nodes without having to display the information.

1. Press **B** to select this option. The following prompt appears:

LOOP ___ NODE ___ TO ___

2. Enter a loop number in the *LOOP* field.
3. Enter a range of nodes in the *NODE* and *TO* fields.
4. Press **ENTER**. If a loop number is entered without specifying a range, pressing **ENTER** starts a printout of all nodes on the loop.

Print Revision Levels on Display - prints the currently displayed revision information. A loop and node must first be selected using option A before using this option. Press **C** to choose the option.

Update Current Node on Display - updates the information currently displaying such as the mode or any error indications that may have occurred since the node information first displayed. Select this option prior to initiating any prints to insure that the most up to date information appears in a printout. Press **D** to choose the option. This updates the information for all modules on the current module revision display.

Press **NEXT PAGE** or **PREV PAGE** to increment or decrement the loop number and call another firmware revision display.

INFI-NET DIAGNOSTICS

The INFI-NET diagnostics function can be used to facilitate the diagnosis of communications related problems. The functions

provide diagnostics information on a loop-wide basis. The functions enable maintenance personnel to:

- Call a graphic that provides a complete overview of all nodes connected to a single communication loop. Only the topology for the loop on which the console resides can be viewed.
- Determine the types of modules in a single node and the module address, revision level, and current operating mode for each module.
- Display the module details for the communication interface modules of a single node in the system. The information presented includes the loop and node address, type for each module that makes up the interface, revision level for each module, and memory utilization of the host module (e.g., INICT01 module).
- View a snapshot of event and error counters for the communications modules of a single node in the system. The information automatically updates every 30 seconds or after an operator request to update the information.
- View a snapshot of exception report statistics for the communications modules of a single node in the system. The information automatically updates every 30 seconds or after an operator request to update the information.
- Print a listing that overviews the entire loop communication system. The listing is for the loop on which the console resides.

Calling the Diagnostics Menu

The first page of the INFI-NET diagnostics function is the options menu. This page allows selecting any node in the system to view diagnostics information for that node.

NOTE: A bridge node does not report communication details, error and event counters, and exception statistics. An error message (*Reply Error - Plant Loop Timeout*) appears when one of these options is selected for a bridge.

Use the *INFI-NET Diagnostics* option to call the INFI-NET diagnostics menu (Figure 21-5). To choose the option, first press **GENL FCTNS MENU**, then select the following menu items in the sequence shown.

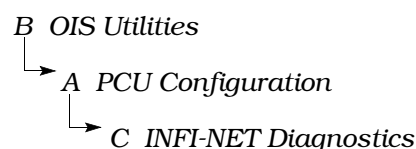

```

SATURDAY NOV 14,1992 11:29:59 INFI-NET DIAGNOSTICS 1 2 14 99 S A
-----
Loop 0 implies self          LOOP 0   NODE 0   Sort Nodec NO
Node 0 implies all nodes

A Select Loop/Node/Sort
B Loop Topology
C Node Topology
D Communication Module Details
E Event and Error Counters
F Event and Error Counters (Resettable)
G Reset Event and Error Counters
H Exception Statistics
I Reset Exception Statistics
J Performance Statistics
K Print Network Topology

THIS CONSOLE:          LOOP 1   NODE 247
TIME SYNC MASTER:     LOOP 1   NODE 164  ACCURACY RATING 9

1
K-S
P-1
con
tun
SHF

```

TPS0838A

Figure 21-5. INFI-NET Diagnostics Menu

When the page is first called, the boxed area at the top of the page shows the current loop and node selected. This is the node for which diagnostics information will be displayed. The sort option being used also appears.

At the bottom of the page are fields that show the loop and node address of this console, the node that is the current time-sync master, and the clock accuracy rating of the time-sync master. Refer to **SET DATE AND TIME** in Section 20 for an explanation of time synchronization and the time-sync master.

The accuracy rating ranges from zero to 12; 12 is the most accurate. Refer to Table 20-1 for clock accuracy ratings.

Selecting a Loop and Node

There are different methods for selecting a node for which to display diagnostics information:

- Using the A *Select Loop/Node/Sort* option on the INFI-NET diagnostics menu (Figure 21-5).
- Using the A *Select Loop and Node for Display* option available on all diagnostics pages except loop topology.
- Pressing **NEXT PAGE** or **PREV PAGE** while viewing the node topology page or either event and error counters pages.

This calls the same information for the node physically located on the loop after or before the current node.

USING THE SELECT LOOP, NODE, AND SORT OPTION

The *Select Loop/Node/Sort* option allows selecting any node in the system. The information presented by options *B* through *I* of the INFI-NET diagnostics menu (Figure 21-5) is for the node chosen with this option.

The *Select Loop/Node/Sort* option is also used to set the sort option. The sort option determines the order in which information presented on various diagnostics pages is to appear.

To select a node and to set the sort option:

1. Press **A** to choose the *Select Loop/Node/Sort* option from the INFI-NET diagnostics menu (Figure 21-5). This enables the input cursor on the *Loop* field at the top of the page.
2. Enter **0** for self or enter the number of any loop in the system from 1 to 250.
3. Enter the number of any desired node on the loop in the *Node* field. A valid entry is from 0 to 250. Use 0 for self or all depending on the function selected.
4. Enter **YES** in the *Sort Nodes* field to have the node information presented by a function appear in chronological order by node address. Enter **NO** to have it appear in order by the physical location on the loop starting with this console.

NOTE: The sort option does not affect the loop topology or node topology pages.

5. Press **ENTER**.

USING THE SELECT LOOP AND NODE FOR DISPLAY OPTION

The *Select Loop and Node for Display* option available from most diagnostic pages can be used to display information for another node without having to exit the current page. To select a node:

1. Press **A** from a diagnostics page to choose the *Select Loop and Node for Display* option. The following prompt appears:

LOOP ___ *NODE* ___

2. Enter **0** for self or enter the number of any loop in the system from 1 to 250 in the *LOOP* field.

3. Enter the number of any desired node on the loop in the *NODE* field. A valid entry is form 0 to 250. Use 0 for self or all depending on the function selected.
4. Press **ENTER**.

Using the Menu Options

The INFI-NET diagnostics function provides a wide range of information to aid in diagnosing communication problems:

- Loop topology.
- Node topology.
- Communication module details.
- Event and error counters.
- Exception report statistics.

NOTES:

1. The *J Performance Statistics* option is not supported in this software release.
2. A bridge node does not report communication module details, event and error counters, or exception report statistics.

The INFI-NET diagnostics functions are intended to help diagnose INFI-NET communication problems. On a Plant Loop system, only the *Node Topology* and *Print Network Topology* functions can be used.

LOOP TOPOLOGY

The *Loop Topology* option calls up a graphic overview of the **current** loop. Press **B** to choose the *Loop Topology* option from the INFI-NET diagnostics menu (Figure 21-5). The option ignores any loop selection made with the *Select Loop/Node/Sort* option.

The selected communication loop is depicted as a continuously connected series of circles (Figure 21-6). Each circle symbol represents a single node connected to the loop. The node at the top center of the page is always this console. The graphic always shows the nodes in their relative position on the loop, not in numerical sequence, regardless of the sort option chosen. The arrows on the page indicate the direction of data flow.

The information on the page and data collection time automatically update every 30 seconds, but only if there has been a change in the loop status since the last update. If desired, a request to update the page can be made. Refer to **Updating Diagnostics Information** in this section for explanation.

Inside the large circle, or the innermost circle depending on the number of nodes depicted, is the loop number and the time at which a snapshot of the loop was taken. Each known node

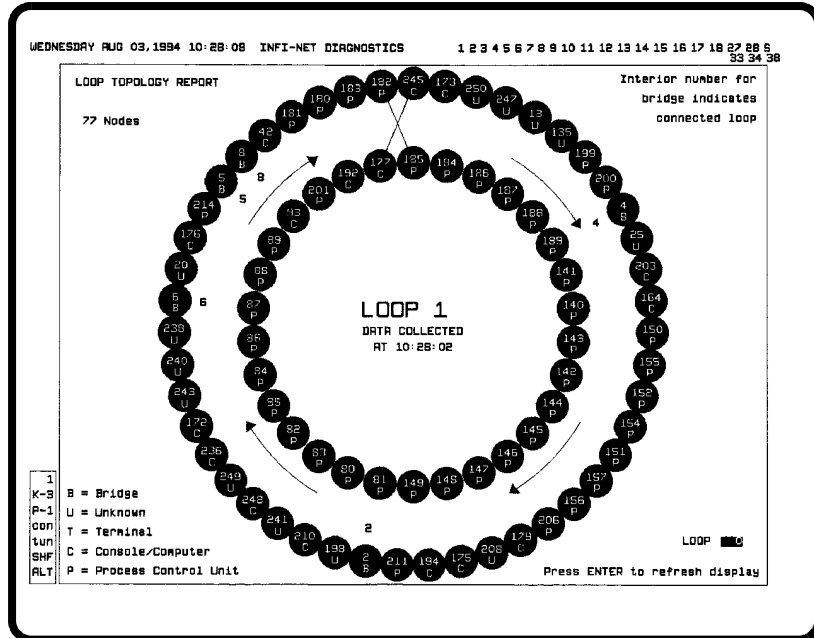

TPS0846B

Figure 21-6. INFI-NET Diagnostics - Loop Topology Page

on the loop is represented by a filled node symbol that indicates the hardware address and type of node. The symbol identifiers for known nodes are:

- B - bridge
- C - console or computer
- P - process control unit
- T - terminal

An unknown node displays as a filled node symbol with a hardware address and with a *U* for unknown category. An off-line node displays as an empty node symbol with a hardware address of 0 and with a *U* for unknown category.

When a snapshot is taken, the console looks for activity (exception reporting) on the loop. If a node is on-line but is not sending any reports at the time the snapshot is taken, the node is identified as unknown. An N90STA tag is not required for the loop topology reporting; however, to avoid an unknown identification due to a nonreporting condition, define an N90STA tag for each node on the loop. This will force a node to exception report status data which includes its type.

The number at the upper left of the page is the total number of nodes for the loop.

For a bridge, the loop number the bridge is providing connection to displays adjacent (towards the center) to the node

symbol. The number of the connecting loop and hardware address of the bridge do not necessarily have to match.

NOTE: A maximum of 85 node symbols can display before the symbols begin to overlap making the node information unreadable.

Loop Failure

Normally, the node symbols appear in green. If there is a loop failure (e.g., broken cable), the page shows a loop snapshot just prior to the failure. The node immediately downstream from the fault location will appear as an empty, red node symbol. All nodes not communicating that are between the console and the node nearest the fault appear in cyan. The nodes that are not communicating are the node symbols downstream from the console and upstream from the node nearest the fault.

Operations

Each node symbol on the loop topology page is defined with a touch point. This allows calling the node topology page for a node directly from the page.

NOTE: The *LOOP* field at the lower right of the page does not function. The loop topology is shown for only the loop the console resides on.

NODE TOPOLOGY

The *Node Topology* option calls a page that details all modules in a selected node. The information displayed is a snapshot of node details. The page automatically updates every 30 seconds or when operator requested. Refer to ***Updating Diagnostics Information*** in this section for further explanation.

NOTE: Each node symbol on the loop topology page is a touch point to allow calling the node topology page directly for a node.

Press **C** to choose the *Node Topology* option from the INFI-NET diagnostics menu (Figure 21-5). The page shows the hardware address, module type, revision level, and operating condition for each module in the node (Figure 21-7). This page is similar to the module revision level display.

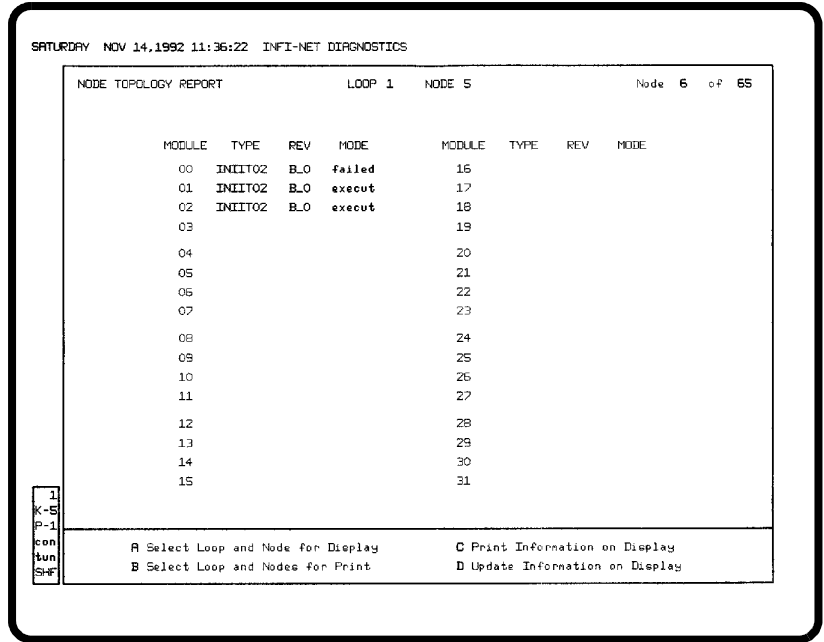

TPS0839A

Figure 21-7. INFI-NET Diagnostics - Node Topology Page

Address The numbers 00 through 31 under the *MODULE* heading correspond to the Controlway or module bus address of each control or communication module within the node. This does not necessarily reflect their physical position within a cabinet.

Type The *TYPE* column indicates the type of module, which appears as either the full nomenclature or an abbreviated nomenclature.

If a communication error occurs, it is shown in the *TYPE* column in the format *Ennn*, where *nnn* is an error code integer number. Refer to the **Hardware** instruction for a list and description of these CIU/NIU error codes (Table 1-2 lists instruction numbers).

Revision Level The *REV* column shows the module firmware revision level. Not all modules are capable of reporting revision level. The type of module and its revision level determine whether the console can display a revision level for that module. If a module is not capable of reporting revision level, the page shows *N/A* in the *REV* column.

A plus sign (+) indicator is shown after the revision level if the module firmware is newer than the information in the **MODULE.RV** file. This file resides in the [DATA.USN02] directory. The function uses information from the file to translate a revision level received in an exception report to an ASCII character string.

In some cases, a module must be in either execute or configure mode to report its status. A fixed function block in the module is read to acquire the revision level. Other modules report revision level as part of their module status exception report while in any of their on-line modes.

Table 21-5 identifies which INFI 90 OPEN modules can and cannot report their firmware revision levels. The revision levels for modules with levels equal to or greater than those listed in the availability column can be displayed.

Mode The *MODE* column indicates the current operating mode for the module.

execut - on-line and in execute mode.

config - on-line and in configure mode.

error - on-line and in error mode. Generally, this indication occurs when a module configuration error exists.

failed - some type of failure, probably an internal error.

NOTE: If a module is off-line, it will not appear in the list.

COMMUNICATION MODULE DETAILS

The *Communication Module Details* option calls a page that details the communication modules of a selected node. The information displayed is a snapshot of the module details. The information does not update until requested or until the next call-up. Refer to **Updating Diagnostics Information** in this section for further explanation.

Press to choose the *Communication Module Details* option from the INFI-NET diagnostics menu (Figure 21-5). The page shows the hardware address, type, revision level, memory utilization, and switch settings for each module that comprises the communications interface of the node (Figure 21-8).

Address The *LOOP* column gives the communication module loop address. The *NODE* column gives the node address.

Type The *TYPE* column indicates the module type, which appears as the full nomenclature.

Revision Level The *REV* column shows the module firmware revision level.

Memory Bytes The *TOTAL BYTES* column shows the total number of memory bytes available in the module.

The *UNUSED BYTES* column shows the total number of unused memory bytes available for the module.

SATURDAY NOV 14, 1992 11:41:34 INFI-NET DIAGNOSTICS

COMMUNICATION MODULE DETAILS Page 1 of 1

LOOP	NODE	TYPE	REV	TOTAL BYTES	UNUSED BYTES	USED BYTES	SWITCH 1	SWITCH 2	SWITCH 3	SWITCH 4
1	247	IIMCP01	D.2	700000	604594	0	01010010	00100011	00000000	
		INSLV01	E.1				00010000	01000000	00000001	11110111
1	249	IIMCP01	D.2	700000	520478	0	01010010	00100011	00000000	
		INSLV01	E.1				00010000	01001000	00000001	11111001

1
K-S
P-1
con
turn
SHF

A Select Loop and Node for Display C Print Information on Display
B Select Loop and Nodes for Print D Update Information on Display

TPS0840A

Figure 21-8. INFI-NET Diagnostics - Communication Module Details Page

The *USED BYTES* column shows the total number of temporary memory bytes allocated.

The memory byte information is usually shown for the host communication module only.

Switch Settings

The *SWITCH n* columns identify the switch settings for the module. A 1 indicates open (off), 0 indicates closed (on).

EVENT AND ERROR COUNTERS

The *Event and Error Counters* options call a page containing a snapshot of event and error counters for a selected node (Figure 21-9). There are two different event and error counters displays: Resettable and nonresettable. The page automatically updates every 30 seconds or when operator requested. Refer to **Updating Diagnostics Information** in this section for further explanation.

Nonresettable

Press **[E]** to choose the *Event and Error Counters* option from the INFI-NET diagnostics menu (Figure 21-5) to call the **nonresettable** event and error counters page for a node. The values returned represent the number of events and errors that have occurred since the most recent manual restart of the node.

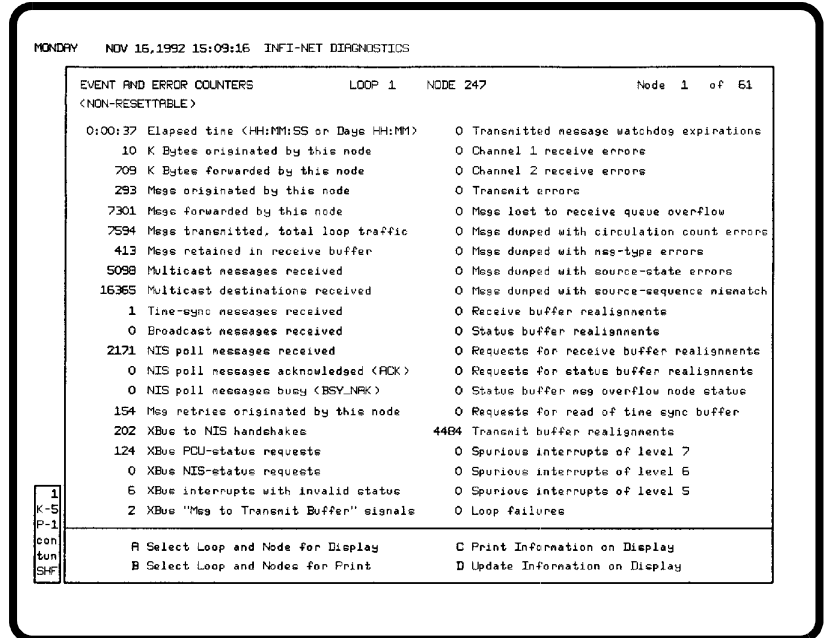

TPS0848A

Figure 21-9. INFI-NET Diagnostics - Event and Error Counters Page

Resettable

Press **F** to choose the *Event and Error Counters (Resettable)* option from the INFI-NET diagnostics menu (Figure 21-5) to call the **resettable** event and error counters page for a node. The values returned represent the number of events and errors that have occurred since the most recent manual restart of the node or the most recent manual reset of the counters.

The event and error counters can be reset to zero at any time. To reset the counters, press **G** to select the *Reset Event and Error Counters* option from the INFI-NET diagnostics menu (Figure 21-5). The following message appears after the counters have been successfully reset:

Event and error counters were reset

In some cases, the reset may not be readily apparent since the counters normally begin to increment again immediately after the reset completes.

If the node address is set to 0 when the reset option is chosen, the event and error counters for all nodes on the loop are reset.

EXCEPTION STATISTICS

The *Exception Statistics* option calls a page that details the exception report processing characteristics (load) for the selected node. The information displayed represents the number of events that have occurred since the most recent manual

restart of the node or the most recent manual reset of the counters. The page automatically updates every 30 seconds or when operator requested. Refer to **Updating Diagnostics Information** in this section for further explanation.

Press **H** to choose the *Exception Statistics* option from the INFI-NET diagnostics menu (Figure 21-5). The page shows the address of the selected node or nodes, elapsed time for the counters, and exception reporting characteristics (Figure 21-10).

Page The *Page n of n* fields show the current page and total number of pages. Press **NEXT PAGE** or **PREV PAGE** to view additional pages.

Address The *LOOP* column gives the communication module loop address. The *NODE* column gives the node address.

Elapsed Time The *ELAPSED TIME* column shows the total amount of time elapsed since the last reset of the counters. The count displayed on the page is the total number of events that occurred during the elapsed time.

MONDAY NOV 15, 1992 15:12:40 INFI-NET DIAGNOSTICS

EXCEPTION STATISTICS		RECEIVED	RECEIVED	SOURCED	SOURCED	RECEIVED	SOURCED
Page 1	of 1	EXCEPTION	EXCEPTION	EXCEPTION	EXCEPTION	EXCEPTION	EXCEPTION
LOOP	NODE	ELAPSED	POINT	PACKET	POINT	PACKET	AVG PERK
		TIME	COUNT	COUNT	COUNT	COUNT	AVG PERK
1	247	0:07:38	94	1307	0	0	0 6 0 0
1	249	3D 22H	66667125	13172872	4471	4471	196 560 0 1
1	140	6D 5H	0	0	6635256	1995304	0 0 12 859

1
K-S
P-J
con
run
SHF

A Select Loop and Node for Display **C** Print Information on Display
B Select Loop and Nodes for Print **D** Update Information on Display

TPS0841A

Figure 21-10. INFI-NET Diagnostics - Exception Statistics Page

Exception Report Statistics The *RECEIVED EXCEPTION POINT COUNT* column shows the total number of exception report messages received by the node.

The *RECEIVED EXCEPTION PACKET COUNT* column shows the total number of exception report packets received by the node. A packet can contain one or more exception report messages.

The *SOURCED EXCEPTION POINT COUNT* column shows the total number of exception report messages sent by the node.

The *SOURCED EXCEPTION PACKET COUNT* column shows the total number of exception report packets sent by the node. A packet can contain one or more exception report messages.

The *RECEIVED EXCEPTION RATE* columns give the average (*AVG*) number of exception report messages received per second by the node during the entire elapsed time. It also shows the maximum (*PEAK*) number of exception report messages received by the node within a one-second period. This is the maximum seen at some time during the entire elapsed time.

The *SOURCED EXCEPTION RATE* columns give the average (*AVG*) number of exception report messages sent per second by the node during the entire elapsed time. It also shows the maximum (*PEAK*) number of exception report messages sent by the node during a one-second period. This is the maximum seen at some time during the entire elapsed time.

The counters of the exception statistics function can be reset to zero at any time. To reset the counters, press **[I]** to select the *Reset Exception Statistics* option from the INFI-NET diagnostics menu (Figure 21-5). The following message appears after the counters have been successfully reset:

Exception statistics were reset

In some cases, the reset may not be readily apparent since the counters normally begin to increment again immediately after the reset completes.

If the node address is set to 0 when the reset option is chosen, the exception statistics for all nodes on the loop are reset.

PRINT NETWORK TOPOLOGY

The *Print Network Topology* option prints a complete list of all nodes and modules on the current loop. The printout contains the hardware address, module type, revision level, and current mode for each module in the system. The hardware address consists of a loop, node, and module number.

The information collected for printing, in most cases, will span several pages. Each page of the printout contains a page number and a start and completion date and time for the information printed on that page.

Press **[K]** to choose the *Print Network Topology* option from the INFI-NET diagnostics menu (Figure 21-5). The following

message and *LOOP*, *NODE*, and *MODULE* fields appear to indicate the current status of the print request:

Print in progress, please wait

The printout can take a variable amount of time depending on the complexity of the system. The console polls each module in each node on each loop in the system to acquire the information for the printout. The *LOOP*, *NODE*, and *MODULE* fields increment to show the address of the module currently being polled.

Do **not** exit the page while the request is being processed. Exiting the page by pressing **ESC** or calling another display cancels the request in progress. Any data already collected, however, is still printed.

A printout occurs at the printer assigned to the window. Look at the keyboard status block of the page to determine which printer.

Printing Diagnostics Information

This section explains the methods used to create a hard copy of displayed diagnostic information. The method to use depends on the option chosen.

SCREEN PRINT

Use the command line menu *PRINT* option to print the information that appears on the loop topology page. The page does not provide any print options. Any other diagnostics page can also be printed in this way. Refer to **SCREEN COPY** in Section 8 for screen print requirements.

It is a good idea to update the information on the page before initiating a print of information to insure that the most up to date information appears in the printout. Refer to **Updating Diagnostics Information** in this section for the procedures.

PRINT OPTIONS

All INFI-NET diagnostics pages except for the loop topology page provide options for printing diagnostics information: *Print Information on Display* option and *Select Loop and Nodes for Print* option. A printout initiated with either option occurs at the printer assigned to the window. Look at the keyboard status block to determine which printer.

A printout occurs at the printer assigned to the window. Look at the keyboard status block of the page to determine which printer. The format of all printed information is the same as

what is seen on the screen except that a time of collection appears on the printout.

Print Information on Display

The *Print Information on Display* option available on certain diagnostics pages allows printing the current diagnostics information presented on the screen. Press **C** to select the *Print Information on Display* option when it is available. The information currently displayed will be printed.

It is a good idea to update the information on the page before initiating a print of information to insure that the most up to date information appears in the printout. Refer to **Updating Diagnostics Information** in this section for the procedures.

Select Loop and Nodes for Print

The *Select Loop and Nodes for Print* option when available can be used to print information for a single node or a range of nodes without having to display the information. Any node on the current loop can be selected with the option.

To use the *Select Loop and Nodes for Print* option:

1. Press **B** to select the option when it is available. The following prompt appears:

LOOP ___ NODE ___ TO ___

2. Enter **0** for self or enter the number of the loop on which the console resides (1 to 250) in the *LOOP* field.
3. Enter a range of nodes in the *NODE* and *TO* fields. Use the same node number in both fields to print the information for a single node. If a loop number is entered without specifying a node address or range of node addresses, the printout contains the information for all nodes on the loop.
4. Press **ENTER**.

Updating Diagnostics Information

The method used to update diagnostics information depends on the option chosen. For the loop topology page, the event and error counters displays, and the exception statistics display, the information automatically updates every 30 seconds. The information can also be updated prior to the 30 seconds with an operator action.

Press **ENTER** at any time to update information while viewing the loop topology page. The page and data collection times do

not update even after pressing **ENTER** or the 30 seconds expires, however, unless there has been:

- A change in the loop status since the initial call-up.
- A change in the loop status since the last update.

The *Update Information on Display* option available on INFI-NET diagnostics displays can be used to update the information currently on display. Press **D** to choose the option prior to initiating any prints to insure that the most up to date information appears in a printout. This updates the information for all nodes on the current page.

SECTION 22 - SYSTEM MANAGEMENT

INTRODUCTION

A configuration loaded into memory defines the operation and operating limits for a control module in the INFI 90 OPEN system. A control module executes this configuration to perform its process control responsibilities. System configuration and management capabilities available on the console give access to these PCU module configurations.

NOTE: Configuration of PCU modules can be performed using a configuration and tuning terminal (CTT), console, or personal computer.

This section provides an explanation and gives the procedures for using INFI 90 OPEN configuration utilities available on the console. The utilities include:

- Module configuration. The mode of a PCU module can be changed and the module can be configured or tuned directly from the console using module configuration utilities.
- PCU management. A PCU module configuration can be saved, verified and restored using PCU management utilities.
- Red tag status. The status for a function block can be viewed and modified.

PCU CONFIGURATION ACCESS

All PCU configuration options require proper security access to perform. The user must have configuration security access rights to use any module configuration function, tune security access rights to use the tuning function, and red tag region access to use the red tag status function. Also, the key must be in the proper position to configure, tune, or modify red tag status for a module if the key enabled. Password security enables or disables the key based on the security level of the user. An error message appears if these conditions are not met.

PCU CONFIGURATION MENU

The PCU configuration functions are accessed from menu selections. Use the *PCU Configuration* option to call the PCU

configuration menu (Figure 22-1). First press **GENL FCTNS MENU** then select the following menu items in the sequence shown.

B Utilities
 ↳
 A PCU Configuration

NOTE: Refer to **INFI-NET DIAGNOSTICS** in Section 21 for information about the **C INFI-NET Diagnostics** option.

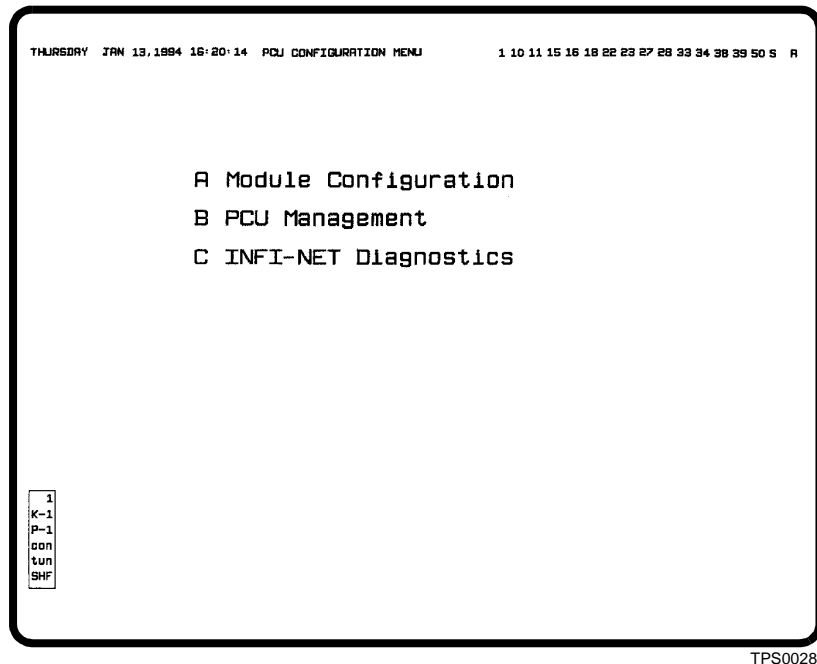

Figure 22-1. PCU Configuration Menu

Module Configuration Option

Press **A** to select *Module Configuration* from the PCU configuration menu (Figure 22-1) to access module configuration functions. This brings up the menu of options shown in Figure 22-2.

The status box at the top of the provides current information such as module type, operating mode, and status of a selected module. This information updates every five seconds. The configuration functions available are explained in the following sections.

CONFIGURING OR TUNING A MODULE

A module must be in **configure** mode to use a configuration option. It must be in **execute** mode for tuning or red tag modification. An error message appears if an attempt to use an option is made while a module is in the wrong mode.

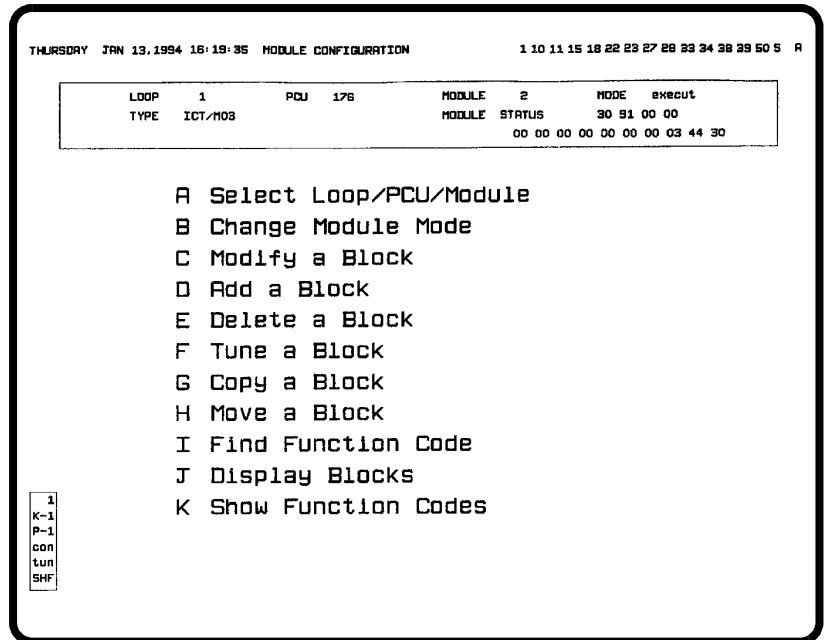

TPS0039B

Figure 22-2. Module Configuration Menu

Since the configuration options directly affect PCU module operations, a confirmation is required for most options before they are performed by the console. The following message appears:

Press ENTER for action; ESC to cancel

Press **ENTER** to confirm the action. This sends a command to the PCU module to perform the desired action. Press **ESC** to cancel the action. No command is sent to the module.

Table 22-1 lists the valid entries for loop, PCU, module, and block address.

Table 22-1. Loop, PCU, Module, and Block Address

Address	Valid Entry
Loop	0 or 1 = Plant Loop system 1 to 250 = INFI-NET system
PCU	1 to 63 = Plant Loop system 1 to 250 = INFI-NET system
Module	0 to 31
Block	0 to 9998 = maximum range; actual range depends on the module type

Any change made to a configuration using either the modify block, tune, add, delete, copy, or move function is logged as an operator action in the event log. The information displayed by

using the modify, tune, display block, and find function code options is similar to that displayed by the block details function. Refer to **Block Details Operations** in Section 11 for a description of the information.

SELECTING A LOOP, PCU, AND MODULE

The *A Select Loop/PCU/Module* option (Figure 22-2) allows accessing a module both to view its current mode and status and to configure or tune its operating parameters. Any control module in the INFI 90 OPEN system can be selected by entering its address. A module must be selected with this option before any module specific operations such as tune or modify can be performed. Select this option at any time to change to a different module.

To select a module:

1. Press **A** to select *Select Loop/PCU/Module*.
2. Enter a module address in the *LOOP*, *PCU*, and *MODULE* fields (Table 22-1), then press **ENTER**.

The status box fields at the top of the page update to reflect the mode, status, and type for the selected module.

CHANGING MODULE MODE

The *B Change Module Mode* option (Figure 22-2) allows changing the mode of operation for the selected module. A module must be in execute mode to perform any tuning or red tag status modification; it must be in configure mode to make configuration changes. Selecting *Initialize* clears the current configuration from memory in the module to allow downloading another. Selecting *Reset* initiates a module circuitry reset.

NOTE: Care should be taken when using the *Initialize* function since it erases module memory. A configuration must then be downloaded for the module to resume its control responsibilities.

To use the option:

1. Press **B** to select *Change Module Mode*. This calls another menu of options. The mode can be set to either execute or configure. The module can also be initialized or reset.
2. Select one of the options from the menu.
3. Press **ENTER** to confirm the action; press **ESC** to cancel the action. The *MODE* field in the status box will update to verify the mode change.

MODIFYING A FUNCTION BLOCK

The *C Modify a Block* option (Figure 22-2) allows making changes to the parameters controlling the operation of a specific function block.

To use the option:

1. Press **C** to select *Modify a Block*.
2. Enter a block address in the *Block number* field (Table 22-1), then press **ENTER**. The current specification values for the selected block display and can be edited.
3. Make any required modifications to the specifications, then press **ENTER**.
4. Press **ENTER** to confirm the action; press **ESC** to cancel the action.

ADDING A FUNCTION BLOCK

The *D Add a Block* option (Figure 22-2) allows adding a function block to the current configuration of the selected module.

To use the option:

1. Press **D** to select *Add a Block*.
2. Both a block address and function code are required to create a function block. Enter a block address in the *Block number* field (Table 22-1) and a function code number in the *Function code* field, then press **ENTER**. Use the *Show Function Codes* option to call a list of valid function codes.
3. All specifications are set to default values when a block is added. Make any required modifications to the specifications, then press **ENTER**. Editing is performed in the same manner as in the *Modify a Block* function.
4. Press **ENTER** to confirm the action; press **ESC** to cancel the action.

Adding a function block over an existing function block is not permitted. If the block address already has a configured function code, an error message will display. To add the new block in the address of an existing block, the existing function block must first be deleted.

DELETING A FUNCTION BLOCK

The *E Delete a Block* option (Figure 22-2) allows deleting a function block from the current configuration of the selected module.

To use the option:

1. Press **E** to select *Delete a Block*.
2. Enter the address of the block to delete in the *Block number* field (Table 22-1).
3. Press **ENTER** to send a delete command to the module. An error displays if the block does not exist; otherwise, it is deleted from the configuration.

TUNING A FUNCTION BLOCK

The *F Tune a Block* option (Figure 22-2) allows tuning the specifications of a function block in the configuration of the selected module.

To use the option:

1. Press **F** to select *Tune a Block*.
2. Enter the address of the block to tune in the *Block number* field (Table 22-1), then press **ENTER**.

An error message will display if the module is not in execute mode, otherwise the current specification values of the selected block display. A tunable parameter is identified by a *T*. Moving to a specification that is not tunable is not permitted.

3. Make all desired tuning changes, then press **ENTER**.
4. Press **ENTER** to confirm the action; press **ESC** to cancel the action.

COPYING A FUNCTION BLOCK

The *G Copy a Block* option (Figure 22-2) allows copying a configured block to another block address.

To use the option:

1. Press **G** to select *Copy a Block*.
2. Enter the address of the source block in the *Copy block* field and the address of the destination block in the *To block*

field (Table 22-1), then press **ENTER**. The source block is read, then copied to the destination address.

Copying a function block over an existing function block is not permitted. If the destination block address already has a configured function code, an error message will display. To copy the source block to the address of an existing block, the existing function block must first be deleted.

MOVING A FUNCTION BLOCK

The *H Move a Block* option (Figure 22-2) allows moving a function block from its current address to another. This is different than *Copy Block*.

To use the option:

1. Press **H** to select *Move a Block*.
2. Enter the address of the function block to move in the *Move block* field and a destination address to move it to in the *To block* field (Table 22-1), then press **ENTER**. The source block is read and copied to the destination address, then the source block is deleted.

Moving a function block to the address of an existing function block is not permitted. If the destination block address already has a configured function code, an error message will display. To move the source block to the address of an existing block, the existing function block must first be deleted.

After issuing a move block command, the console searches a module configuration for all function blocks that reference the old address of the block being moved. It then automatically changes the specifications for these blocks to the new block address. Some function blocks have more than one output with a separate block address for each output. In this case, the same check is performed for all block addresses and any specifications are changed as required.

FINDING A MODULE FUNCTION CODE

The *I Find Function Code* option (Figure 22-2) allows finding a specific function code within the configuration of a module. This can be used to find a function block when the function code is known but the block address is not.

To use the option:

1. Press **I** to select *Find Function Code*.
2. Enter a starting block number in the *Search from block* field (Table 22-1) and the number of a function code to search

for in the *Function code* field, then press **ENTER**. Use the *Show Function Codes* option to call a list of valid function codes. Each block is read beginning from the start address until a block configured with the desired function code is found. The block parameters will appear after a block is found.

To continue the search:

1. Press **ESC** to exit the parameters page for a found block. This exits back to the input page for the *Find Function Code* option.
2. Press **ENTER** to continue the search starting after the last found block.

DISPLAYING THE MODULE FUNCTIONS BLOCKS

The *J Display Blocks* option (Figure 22-2) allows displaying a block configured in a module.

1. Press **J** to select *Display Blocks*.
2. Enter a starting block address in the *Search from block* field (Table 22-1), then press **ENTER**. The parameters for the block in the starting address or the first block found after the starting address will appear.

To continue and view the next configured function block:

1. Press **ESC** to exit the parameters page for a found block. This exits back to the input page for the *Display Blocks* option.
2. Press **ENTER** to continue the search starting after the last found block.

VIEWING A FUNCTION CODE LIST

The *K Show Function Codes* option (Figure 22-2) allows viewing a complete list of available INFI 90 OPEN function codes. Press **K** to select the option. The list gives the noun name of a function code along with its number. The list spans several pages, each page containing 64 codes. Press **NEXT PAGE** or **PREV PAGE** to move between the pages.

PCU Management Option

PCU management allows saving, loading, verifying, and printing module configurations. Press **B** from the PCU configuration menu (Figure 22-1) to call the PCU management menu (Figure 22-3).

operation. The selector returns to its original red color after the operation completes for all modules, and the following message appears:

Processing of modules n thru n complete

The only exception to this is the *A Select Loop/PCU/Modules/Media* option. All other management functions reference the selections made with the option.

SELECTING LOOP, PCU, MODULES, AND MEDIA

The *A Select Loop/PCU/Modules/Media* option (Figure 22-3) selects a single module or a range of modules on which to perform PCU management functions. This option also specifies the type of media and version to use when initiating these functions. Select this option at any time to change to a different process control unit and modules.

Any process control unit in the INFI 90 OPEN system and any control modules within that process control unit can be selected. A process control unit and module must be selected with this option before performing any management operations. All PCU management functions affect only one process control unit at a time. Most management options can be performed on a range of modules within a process control unit.

To select modules and a media:

1. Press **A** to select *Select Loop/PCU/Modules/Media*. Figure 22-4 shows the page called after selecting the option.
2. Enter the address of a process control unit in the *LOOP* and *PCU* fields (Table 22-1).
3. Enter a single or range of modules in the *MODULES* ___ *thru* ___ fields.
4. The *VERSION* field determines whether the data is current PCU module data (*CURRENT*) or archived data (*HISTORICAL*). Enter the desired version as either **CURRENT** or **HISTORICAL**. The *VERSION* field is described in more detail in **Media Version** and **Locating Saved Data** in this section.
5. Press **ENTER**. The status box at the top of the page updates to reflect the entered address and media.

Media Version

The *VERSION* field (Figure 22-4) determines where configurations are to be saved to and where they are to be loaded, verified, or printed from. Configurations are saved to two separate

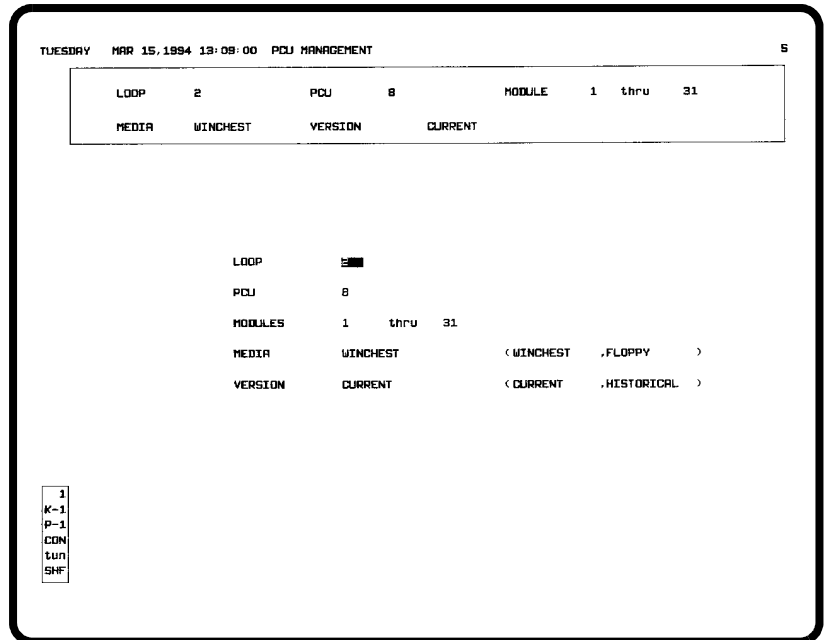

TPS0030B

Figure 22-4. Select Loop/PCU/Modules/Media

directories: A current directory or an archival storage directory. This field determines which directory is used.

Current Directory

The current directory is used to store data that is to remain on the console hard disk. The configurations in this directory remain on the hard disk until deleted by using a function of PCU management. This saved data can be loaded, verified, or printed at any time.

Archival Storage Directory

The archival storage (or *HISTORICAL*) directory provides temporary storage of PCU configurations until a scheduled archive to medium occurs. All saved configurations automatically save to this directory if archival storage has been turned on for PCU configurations.

Archived configurations can only be loaded, verified, and printed after first being retrieved by using archival retrieval functions. A retrieved configuration is stored in an archival retrieval directory. This directory is separate from the archival storage directory.

Refer to **ARCHIVE DATA STORAGE** and **ARCHIVE DATA RETRIEVAL** in Section 19 for further explanation.

Locating Saved Data

The current directory contains only those configurations that are saved while the version is set to *CURRENT*. Configurations are automatically saved to both the current and archival

storage directories while the version is *CURRENT* as long as archival storage has been turned on for PCU configuration data. When the version is *HISTORICAL*, no configurations are stored to the current directory. They store to the archival storage directory only, but only if archival storage has been turned on for PCU configurations.

The *VERSION* field determines where the console is to look for configuration data when performing load, verify, and print operations. If *CURRENT*, configurations saved in the current directory are retrieved. Configurations are retrieved from the archival retrieval directory when the version is *HISTORICAL*.

CHANGING MODULE MODE

The *B Change Mode of Modules* option (Figure 22-3) allows changing the mode of operation for the selected modules. A module must be in execute mode to perform its control responsibilities. A module must be in configure mode to load a configuration. Selecting *Initialize* clears the current configuration from memory of a module to allow downloading another. Selecting *Reset* initiates a module circuitry reset.

NOTE: Care should be taken when using the *Initialize* function since it erases module memory. A configuration must then be downloaded for the module to resume its control responsibilities.

Only one module at a time can be put into **configure** mode using this utility. If a range of modules is specified, attempting to put the modules in configure mode causes an error:

Limited to one module at a time

To use the option:

1. Press **[B]** to select *Change Mode of Modules*. This calls another menu of options. The mode can be set to either execute or configure. A module can also be initialized or reset.
2. Select one of the options from the menu.
3. Press **[ENTER]** to confirm the action; press **[ESC]** to cancel the action.

SAVING A MODULE CONFIGURATION TO MEDIA

The *C Save Configuration to Media* option (Figure 22-3) allows saving configurations. are saved to a directory determined by the *VERSION* field. Refer to **Media Version** in this section for an explanation of this field.

Each configuration that is saved stores in a file containing only one configuration. Previously saved configurations are

overwritten when a new save request is made. A configuration file for a specific module can be identified by its loop, PCU, and module address.

To use the option:

1. Press **C** to select *Save Configuration to Media*.
2. Press **ENTER** to confirm the action; press **ESC** to cancel the action.

LOADING A MODULE CONFIGURATION FROM MEDIA

The *D Load Configuration from Media* option (Figure 22-3) allows downloading a configuration to a selected module from a selected medium. A module that the configuration is being downloaded to must be in **configure** mode. If specifying a range of modules, an informational message identifies which modules are not in configure mode.

To use the option:

1. Press **D** to select *Load Configuration from Media*.
2. Press **ENTER** to confirm the action; press **ESC** to cancel the action.

VERIFYING A MODULE CONFIGURATION AGAINST MEDIA

The *E Verify Configuration against Media* option (Figure 22-3) allows verifying module configurations against previously saved configurations. The first error encountered terminates the verification process. The error is identified with a message. After correcting an error by either repeating a download or modifying the configuration in the module, the verify can be attempted again. If the same or another error occurs, it is again identified.

To use the option:

1. Press **E** to select *Verify Configuration against Media*.
2. Press **ENTER** to confirm the action; press **ESC** to cancel the action.

PRINTING MODULE CONFIGURATIONS

The management functions provide two options for printing configuration data: *F Print Configuration from Media* and *G Print Configuration from Modules*. A printout occurs at the printer assigned to the window. Look at the keyboard status block to determine which printer. Configurations print in a standard format.

From Media The *F Print Configuration from Media* option (Figure 22-3) initiates a printout of configurations previously saved. To use the option:

1. Press **F** to select *Print Configuration from Media*. The *VERSION* field entry determines whether the data is from the current directory or the archival retrieval directory.
2. Press **ENTER** to confirm the action; press **ESC** to cancel the action.

From Modules The *G Print Configuration from Modules* option (Figure 22-3) initiates a printout of each configuration that currently resides in memory of the selected modules. This option references only the loop, PCU, and module address selections. To use the option:

1. Press **G** to select *Print Configuration from Modules*.
2. Press **ENTER** to confirm the action; press **ESC** to cancel the action.

After choosing either print option, the configuration information is collected and formatted for printing. The following message appears to indicate the status:

Processing page n

Exiting the page after making a selection and while the message is displaying cancels the printout.

Other informational messages appear to identify which module configuration is currently being processed and to identify when processing is complete.

REQUESTING A DIRECTORY OF MODULE CONFIGURATIONS

The *H Display Directory of Configurations* option (Figure 22-3) allows viewing a directory display that lists the PCU configurations stored in the current directory. The listing is for the current directory only. The *MEDIA* and *VERSION* fields are ignored for this option. The archival storage and retrieval function provides a directory function for viewing retrieved (*HISTORICAL*) PCU configurations. Refer to **ARCHIVE DATA RETRIEVAL** in Section 19 for more information.

Press **H** to select *Display Directory of Configurations* to view a directory (Figure 22-5). Each directory entry contains a loop, PCU, and module number and a storage time. Each entry is for a single module. The directory listing is in numerical order by loop, PCU, and module number. A single directory page can show 22 entries. Press **NEXT PAGE** or **PREV PAGE** to view additional pages.

MONDAY 21-MAR-94 10:58:09 PCU MANAGEMENT 97 A

DIRECTORY OF CURRENT PCU CONFIGURATIONS PAGE 1

Loop	Node	Module	Time	Loop	Node	Module	Time
A	2	B	5	10:47:04	21-MAR-94	L	
B	2	B	12	10:48:27	21-MAR-94	M	
C						N	
D						D	
E						P	
F						Q	
G						R	
H						S	
I						T	
J						U	
K						V	

X Delete Selected Y Delete Page

1
K-1
P-1
con
TUN
SHF

TPS0032B

Figure 22-5. Display Directory of Configurations

At the bottom of the display are two options for deleting saved configuration files: *X Delete Selected* or *Y Delete Page*.

To delete selected configurations:

1. Press **X** to select *Delete Selected* option. The letters next to each configuration listed in the directory turn red to indicate that the page is in delete mode.
2. Select the configurations that are to be deleted by pressing the selector keys for the configurations. The letter next to an entry indicates the key to press.
3. After all files to delete have been selected, press **ENTER** to initiate the deletion. Press **ESC** at any time before pressing **ENTER** to exit delete mode.

To delete all configurations listed in the directory:

1. Press **Y** to select the *Delete Page* option. The border of the page highlights.
2. Press **ENTER** to initiate the deletion.

RED TAGGING

NOTE: The red tag status function does *not* lock out the power source for the actual equipment. The user must de-energize the power source and implement red tagging in compliance with the ANSI Z244.1 specification. Red tag status reported to the console is for display purposes only.

Red tagging allows indicating from the console that a piece of equipment is out of service. A red tag status message is sent to a function block in a PCU module to either set or remove a red tag. The function block stores and reports this status in an exception report, which allows other consoles and other types of operator interface devices to read and display the status.

Red tag status can be viewed and a red tag indication can be set or removed from a function block by using the *Red Tag Status* option or by using the *Red Tag Status Dialog Box*. Any red tag changes are recorded in the event log (or operator actions log). The central red tag information repository only retains set red tag indications.

The event log records information such as the operator identification and a red tag note. This information can only be displayed on the console where the red tag was set. Refer to **LOGGING** in Section 18 for more information.

The central red tag information repository stores additional information on the red tag key such as the operator who set the key and the date/time it was set. The central red tag information repository also allows for viewing of red tag information from any console in the system.

A red tag note is stored in the event log with the red tag key. This note can be used to indicate the reason the device was red tagged or for any additional information pertaining to the setting or removing red tag key. This note is required by the function. The central red tag information repository only retains red tag notes from set red tag keys.

Table 22-2 lists the tags and their associated function codes (FC) that allow for red tagging.

Table 22-2. Red Tag Capable Tag Types

Tag	Function Code
DANG	Data acquisition analog, FC 177
DADIG	Data acquisition digital, FC 211
DD	Device driver, FC 123
MSDD	Multi-state device driver, FC 129
RCM	Remote control memory, FC 62
RMCB	Remote motor control, FC 136

Table 22-2. Red Tag Capable Tag Types (continued)

Tag	Function Code
STATION	M/A station (basic), FC 21; M/A station (cascade), FC 22; M/A station (ratio), FC 23; control station, FC 80
TEXTSTR	User-defined data export, FC 194. Sequence of events slave, FC 210

Red Tag Keys

Up to three red tag keys can be applied to a single function block. Two options are available for setting up red tag keys. A user can be assigned a unique three-character key or can be left unassigned. Red tag key assignments are made during password security configuration.

Assigning a key restricts a user to performing set and remove operations using only the assigned key. For example, an operator having an assigned key of ABC can only set red tag status with the ABC key. Additionally, the operator can only remove an ABC key.

A user that does not have a red tag key assigned can use any valid three-characters as a key. A user not assigned a red tag key also has the ability to set and remove **any** key even if it is assigned to another user.

Central Red Tag Information Repository

The central red tag information repository application is a red tag database used for insertion, deletion and retrieval of red tag information. the application is designed to run in a dedicated MFP module. Contact Elsag Bailey for information about the red tag information repository (SRTR01).

Displaying Red Tag Status

Any faceplate element or display can be built to indicate red tag status for a function block. One indication that can be used is red tag status text (**ed 100**). The default text is *RT*. Another indication that can be used is a change in the outline of a display element (**ed 102**). Using this method, the outline color changes to red to indicate that red tag is set for a function block. Refer to the **Display Builder Reference** instruction for further explanation (Table 1-2 lists instruction numbers).

The source file for a display or display element may need to be modified to enable the red tag status outline feature. In standard faceplate elements provided, the remark (**rm**) at the beginning of the line containing the **ed 102** command must be removed. In custom faceplates, the **ed 102** command must be added to the source file.

Calling the Red Tag Status Page

The display used to view or modify red tag status is called by using the *Red Tag Status* option. To choose the option, first press **GENL FCTNS MENU** then select the following menu items in the sequence shown.



Figure 22-6 shows the red tag status display after a function block has been selected. Refer to **Selecting a Tag or Function Block** in this section for the procedures to call the status for a function block.

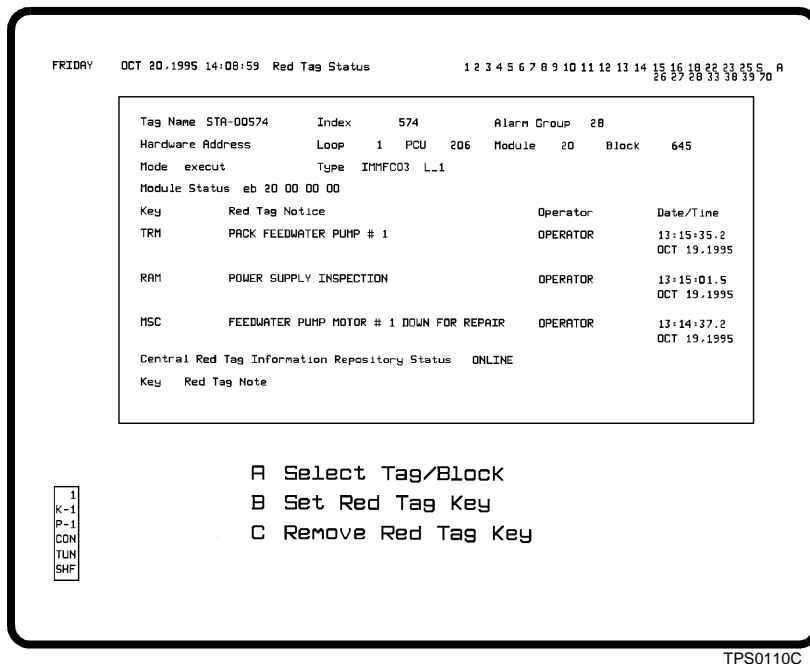

Figure 22-6. Red Tag Status

Selecting a Tag or Function Block

When the red tag status display is first called, a *SELECT TAG OR BLOCK* prompt appears. Any function block can be selected by entering the name or index number of a tag defined for the block. Optionally, a function block can be selected by entering its block address.

To select a function block:

1. Enter a tag name or index number in the *TAG NAME/INDEX* field if known. Red tag modification can then be performed on the function block defined by the tag. The tag data-

base is checked for function block loop, PCU, module, and block address.

If a tag name or index number is not known, select a function block by its block address. Enter a function block address in the *LOOP*, *PCU*, *MODULE*, and *BLOCK* fields (Table 22-1).

In either case, a function block must be capable of red tagging or a message indicating an invalid block selection will appear. Information for the block will still be displayed, however. Refer to Table 22-2 for a list of red tag capable function codes.

2. Press **ENTER**. After selecting a function block, the status box at the top of the display updates to show the tag index, alarm group, tag name, and block address of the function block and the module type, mode, and status of the module in which the block resides. It also displays the status of the central red tag information repository.

The *KEY* fields in the status box show the current red tag status of the block. If all *KEY* fields are blank, the block is not currently red tagged. If any *KEY* field contains alphanumeric characters (red tag key), the block is red tagged. The three *KEY* fields allow for three different red tag keys to be applied to the block.

If the central red tag information repository is defined and on-line, the red tag notice, operator name, and date and time that the red tag key was set will also be displayed.

NOTE: If the red tag keys were set before the installation of the H.2 software or the central red tag repository was off-line when the red tags were set only the red tag keys will be displayed.

Use the *A Select Tag/Block* option to select another function block:

1. Press **A** to select the option. A *SELECT TAG OR BLOCK* prompt appears.
2. Enter a tag name, index number or a block address as described in the previous steps.

Setting a Red Tag Key

The *B Set Red Tag Key* option (Figure 22-6) sets a red tag key for the selected function block. It operates two ways depending on the password definition for the currently logged in operator. Three keys can be applied to a single function block; however, only one key is required to set red tag for a function block. Duplicate keys cannot be applied.

To apply a red tag key to the selected function block:

1. Press **B** to select *Set Red Tag Key*.
2. If the currently logged in operator does not have a red tag key assigned, enter a three-character key in the *KEY* field. Any three-character key can be entered even if it is assigned to another user. A valid entry can consist of the characters A through Z (uppercase only), 0 through 9, colon (:), dollar (\$), period (.) and space. An input of three spaces, however, is not permitted. Press **TAB** to move to the *RED TAG NOTE* field after entering the key.

If the currently logged in operator has an assigned red tag key, the three-character key appears in the *KEY* field automatically. The key cannot be modified. The input automatically moves to the *RED TAG NOTE* field.

3. Enter a note of up to 80 characters. This is required and the console will not proceed without it.
4. Press **ENTER** to initiate the change. The red tag key characters appear in the next available *Key* field on the display to indicate a successful red tagging. Press **ESC** anytime before **ENTER** to cancel the action. The faceplate element or display that provides a red tag indication for the block will update as soon as the change is made.

The set red tag key information will be stored at both the function block and, if it is on-line, the central red tag information repository.

Removing a Red Tag Key

The *C Remove Red Tag Key* option (Figure 22-6) removes a red tag for the selected function block. It operates two ways depending on the password definition for the currently logged in user. All keys must be cleared to remove red tag from a function block.

To remove a red tag key from the selected function block:

1. Press **C** to select *Remove Red Tag Key*.
2. If the currently logged in operator does not have a red tag key assigned, enter any one of the red tag keys currently set for the block in the *KEY* field. Any keys previously set can be removed. Press **TAB** to move to the *RED TAG NOTE* field.

If the currently logged in operator has an assigned red tag key, the three-character key appears in the *KEY* field automatically. This is the only key that this operator can remove. The input automatically moves to the *RED TAG NOTE* field.

3. Enter a note of up to 80 characters. This is required and the console will not proceed without it.
4. Press **ENTER** to initiate the change. The red tag key characters are removed from one of the three *Key* fields on the display. Press **ESC** anytime before **ENTER** to cancel the action.

The function block is still red tagged if any *Key* field has characters in it. The faceplate element or display that provides a red tag indication for the function block will not remove the red tag indication until all keys are cleared.

When a red tag key is removed it is deleted from both the function block and, if it is on-line, the central red tag information repository.

RED TAGGING FROM OIS DISPLAY

All operations that can be performed through the *Red Tag Status Option* can also be performed from the *Red Tag Status* dialog box. This dialog box is accessed through the *OIS Operation* pull-down menu option, a red tag button on a touch pad, a configured red tag touch point, or a red tag key select. The dialog box provides access to commands which allow the red tag key to be set or removed without having to close the current graphic display.

Accessing the Red Tag Status

The red tag status dialog box is accessed by either:

1. Clicking on the *OPERATION OIS* menu option.
2. Clicking *RED TAG STATUS* in the pull-down menu.

- or -

Pressing the *RED TAG* button or touch point on the touch screen.

Figure 22-7 shows the red tag status dialog box after a function block has been selected. Refer to **Dialog Box Fields** in this section for the procedures to perform red tagging from the dialog box.

Dialog Box Fields

The fields of the Red Tag Status dialog box include:

TAG NAME field allows entering a tag name or tag index defined for a function block. If a tag or graphic symbol on the graphic display is selected before the dialog box is accessed, the cur-

rent information on that tag will be displayed. If a tag is not selected a cursor will appear in the field.

Red Tag Status

Tag Name: STA-00574 Tag Index: 574 Alarm Group: 28

Hardware Address: Loop: 1 PCU: 206 Module: 20 Block: 645

Mode: execut Type: IMMFC03 L.1

Module Status: eb 20 00 00 00

Key	Red Tag Notice	Operator	Date/Time
TRM	PACK FEEDWATER PUMP # 1	OPERATOR	OCT 19, 1995 13:15:35.2
RAM	POWER SUPPLY INSPECTION	OPERATOR	OCT 19, 1995 13:15:01.5
MSC	FEEDWATER PUMP MOTOR # 1 DOWN FOR REPAIR	OPERATOR	OCT 19, 1995 13:14:37.2

Central Red Tag Information Repository Status: ONLINE

Key Red Tag Note

Set Remove Clear Close

TPS1175A

Figure 22-7. Red Tag Status Dialog Box

A block is not required to have an associated tag in the console tag database in order for the operator to perform a red tag operation on that particular block. When a tag or block address is entered the red tag information stored at the central red tag information repository, for that function block, is displayed in the dialog box.

NOTE: If a red tag key is set at the function block, but no information is stored in the central red tag information repository, only the red tag key will be displayed in the dialog box.

ALARM GROUP field displays the alarm group number of the selected tag. This field will be blank if the function block does not have an associated tag in the console tag database.

HARDWARE ADDRESS displays the *LOOP*, *PCU*, *MODULE*, and *BLOCK* of the selected tag. If a tag name or index number is not known, select a function block by entering the appropriate function block address in these fields (Table 22-1).

MODE field displays the current operational mode of the module in which the function block resides.

TYPE field displays the module type and revision level of the module in which the function block resides.

MODULE STATUS field displays the current status of the module in which the function block resides.

KEY, *RED TAG NOTICE*, *OPERATOR NAME*, and *DATE/TIME* fields display associated red tag information for the selected tag or block. The information from up to three red tag keys can

be displayed at one time. The information is displayed in a reverse chronological fashion where the most recently set red tag is listed first. The date and time field is formatted in accordance to the consoles date and time format configuration. If the central red tag information repository is off-line or is undefined, only the red tag keys are displayed.

If a mismatch between the red tag keys stored in the block and in the central red tag information repository occurs an error message is displayed along the bottom of the dialog box. Also, the entry in the central red tag information repository will be automatically deleted. The error message will also be stored in the diagnostic error log. A red tag key stored in a block does not have to have a matching entry in the central red tag information repository.

CENTRAL RED TAG INFORMATION REPOSITORY STATUS field will display the current operational status of the central red tag information repository. One of the following three conditions will be displayed in the field: *UNDEFINED*, *ONLINE*, or *OFFLINE*.

- *UNDEFINED* is displayed if the central red tag information repository is not defined for the console. Refer to the **Configuration** instruction for information on how to define the central red tag information repository (Table 1-2 lists instruction numbers).
- *ONLINE* is displayed if the central red tag information repository is defined and the specified module in the execute mode.
- *OFFLINE* is displayed if the central red tag information repository is defined and the specified module is in one of the following modes: off-line, error, or config. The operator will be prompted with the following message: Central Repository off-line, continue (Yes/No)?. A YES response is required before a SET or REMOVE operation can be executed. The red tag keys can be changed regardless of the operational status of the central red tag information repository.

KEY field is for entering a red tag key when the operators' password security account does not contain a predefined red tag key.

RED TAG NOTE field is for entering a note that provides information on why the red tag was set or removed. The note can be up to 80 characters long and is required.

Dialog Box Buttons

The *Red Tag Status* dialog box buttons perform the following functions:

SET button stores red tag key in the selected function block and, if on-line, to the central red tag information repository.

REMOVE button deletes the red tag key in the selected block and, if on-line, the central red tag information repository.

CLEAR button clears all available input fields in the dialog box, and places cursor in Tag Name field.

CLOSE button exits *Red Tag Operations* dialog box. This button can be selected at any time.

Setting a Red Tag Key

The *SET* button (Figure 22-7) sets a red tag key for the selected function block. Up to three red tag keys can be applied to a single function block; however, only one is required. Duplicate keys cannot be applied.

1. In order to set a red tag key, a function block must first be selected. This can be done using one of two methods. Either:

Select a tag or graphic symbol on the display graphic before the red tag status dialog box is accessed. This causes information from that tag or block to be displayed in the dialog box.

NOTE: In order for red tag information from a selected tag on the display graphic to appear in the dialog box the Build Select Tag Table field, on the General Parameters Page, must be set to yes to enable building a tag table when the display is generated (i.e. built). Refer to the **Configuration** instruction for further explanation (Table 1-2 lists instruction numbers).

- or -

Enter a tag name or tag index in the *TAG NAME* field or the block address in the *HARDWARE ADDRESS* fields.

Press **TAB** or **ENTER** key after making an entry into any of the fields. If the entry is not valid for both red tag operations, an error message is displayed along the bottom of the dialog box. If the block address is entered a validation is performed to ensure that red tag operations can be performed on the block type.

Once the entered tag name/index or block address has been validated the cursor appears in the *KEY* entry field if operator password security does not contain a predefined red tag key.

If the account does have a predefined red tag key, the cursor appears in the *RED TAG NOTICE* field.

Also, the *SET* button must be active. This button becomes active when: a valid red tag key is enter in the *KEY* field, not all of the allowable three red tag keys per function block are set, the operator has the proper security access, and the module containing the function block is in the execute mode.

2. If the currently logged in operator does not have a red tag key assigned, enter a three-character key in the *KEY* field. Any three-character key can be entered even if it is assigned to another user. A valid entry can consist of the characters A through Z (uppercase only), 0 through 9, colon (:), dollar (\$), period (.) and space. An input of three spaces, however, is not permitted. Press **TAB** to move to the *RED TAG NOTE* field after entering the key.

If the currently logged in user has an assigned red tag key, the three-character key appears in the *KEY* field automatically. The key cannot be modified. The input automatically moves to the *RED TAG NOTE* field.

3. Enter a note of up to 80 characters. This is required and the console will not proceed without it.

4. Click on *SET* button to save set the red tag key. The red tag key characters appear in the next available key field on the display to indicate a successful red tagging. If setting the red tag key is unsuccessful an error message is displayed along the bottom of the dialog box. Click on *CLEAR* button before *SET* button to remove entries from input fields without setting the red tag key. The *CLEAR* button also allows for other red tag keys to be set for other function blocks without exiting the dialog box. Click on *CLOSE* button once all changes are made to close the dialog box.

The faceplate element or display that provides a red tag indication for the block will update as soon as the change is made.

The set red tag keys will be stored at both the function block and, if it is on-line, the central red tag information repository. If an error occurs when trying to store red tag key information to the central red tag information repository an error message will be displayed along the bottom of the dialog box and the operator will be prompted to allow the red tag key to be set at the function block without saving information in the central red tag information repository.

Removing a Red Tag Key

The *REMOVE* button (Figure 22-7) removes a red tag key from the selected function block. It operates two ways depending on

the password definition for the currently logged user. All keys must be cleared to remove a red tag from a function block.

1. In order to remove a red tag key, a function block must first be selected. This can be done using one of two methods described under **Setting a Red Tag Key** in this section. That is:

Select a tag or graphic symbol on the display graphic before red tag status dialog box is accessed. This causes information from that tag/block to be displayed in the dialog box.

- or -

Enter a tag name or tag index in the *Tag Name* field or the block address in the *Hardware Address* fields.

2. If the currently logged in operator does not have a red tag key assigned, enter any one of the red tag keys currently set for the function block in the *KEY* field. Any keys previously set can be removed. Press **TAB** to move to the *RED TAG NOTE* field, after entering the key.

If the currently logged in operator has an assigned red tag key, the three-character key appears in the *KEY* field automatically. This is the only key that this operator can remove. The input automatically moves to the *RED TAG NOTE* field.

3. Enter a note of up to 80 characters. This is required and the console will not proceed without it.

4. Click on *REMOVE* button to remove the red tag key. The red tag key characters are removed from one of three *KEY* fields on the display. Click on *CLEAR* button before *REMOVE* button to remove entries from input fields without removing any red tag keys. The *CLEAR* button also allows for other red tag keys to be removed from other function blocks without exiting the dialog box. Click on *CLOSE* once all changes are made to close dialog box.

The function block is still red tagged if any *Key* field has characters in it. The faceplate element or display that provides a red tag indication for the function block will not remove the red tag indication until all keys are cleared.

Removal of a red tag key will occur at both the function block and, if it is on-line, the central red tag information repository. If an error is detected when trying to remove a red tag key from the function block an error message will be displayed and the red tag remains set. If an error is detected in the removal of a red tag key from the central red tag information repository the operator will be prompted to remove the red tag key from just the function block or quit the operation.

cancels any changes made to any of the menu selections, and **ENTER** confirms the change in settings.

The following menu selections are available:

GROUP BY BLOCK? This selection allows the operator to either generate the summary in a reverse chronological order or by a reverse chronological/function block order. A **NO** response causes the red tag keys to be listed in an order where the most recent set red tag key is listed first. A **YES** selection results in the red tag keys listed in both a reverse chronological order and by function block. That is, the most recently set red tag key is listed first followed by other red tag keys set for the same function block regardless of the time they were set. Other red tag keys set for the other function blocks are listed in the same way.

DISPLAY/PRINT. This selection causes the generated summary to either appear on the display or be printed out.

SELECT ALL NOTICES. This selection allows the operator to choose which red tag keys and/or information is to be included in the generated summary. A **YES** response generates a summary that contains all the red tags stored in the central red tag information repository. A **NO** response allows the operator to choose which red tags to include in the generated summary. That is, filters are applied when the summary is generated. The filter selections are listed below the *SELECT ALL NOTICES* menu selection, as shown in Figure 22-8. Any number of filters can be applied at the same time.

TAG NAME/INDEX. This filter selection will cause the inclusion of only the red tag keys that have a specified tag name or index number in the generated summary. The operator is required to enter a tag name or index number when a **YES** response is entered. A **NO** response indicates that this filter is not used when the summary is generated.

HARDWARE ADDRESS. This filter selection will cause the inclusion of only the red tag keys set for a chosen function block in the generated summary. A **YES** response requires the operator to enter in the address of the function block. A **NO** response indicates that this filter is not used when the summary is generated.

ALARM GROUP. This filter selection will cause the inclusion of only the red tag keys set for a chosen alarm group in the generated summary. A **YES** response requires the operator to enter in the alarm group number. A **NO** response indicates that this filter is not used when the summary is generated.

USER ACCOUNT NAME. This filter selection will cause the inclusion of only the red tag keys assigned by a particular operator to be included in the summary. A **YES** response

requires the operator to enter in the operator name. A **NO** response indicates that this filter is not used when the summary is generated.

RED TAG KEY. This filter selection will cause the inclusion of only the red tag keys that have a particular key setting to be included in the summary. A **YES** response requires the operator to enter in the key setting. A **NO** response indicates that this filter is not used when the summary is generated.

TIME/DATE RANGE. This filter selection will cause the inclusion of only the red tag keys that have been set between chosen dates and times to be included in the summary. A **YES** response requires the operator to enter in a start and end date and time. A **NO** response indicates that this filter is not used when the summary is generated.

Generating a Summary

To generate a summary of the red tag keys in the central red tag information repository press **B**

The generated listing will include the following information: date and time red tag key was set, tag name, function block address, tag index, alarm group, operator who set tag, red tag key, and red tag notice. The summary is displayed or printed in reverse chronological order with the most recent set red tag keys listed first. The dates and times are displayed or printed in the current console configuration format. Table defines the time needed for the console to receive all query replies from a full central red tag information repository and display the first page.

Table 22-3. Red Tag Information Repository Query Times

Module Type	Max Number of Tags	Max Time (min)
IMMFP01	75	1
IMMFP02	310	4
IMMFP03	725	10

If the central red tag information repository is not defined for the console or if it is defined but off-line an error message will be displayed and no summary will be generated.

APPENDIX A - AUXILIARY ENGINEERING KEYBOARD

KEYBOARD

The keys on the operator keyboard are mapped to the auxiliary engineering keyboard. This allows accessing console functions directly from the engineering keyboard. There are three types of auxiliary engineering keyboards available: IIAKB02, IIAKB03, or LK-201 keyboard.

Figure A-1 shows the auxiliary engineering keyboard providing a cross reference to the operator key functions. There are some differences in layout between each type of auxiliary engineering keyboard, but the capabilities and functions accessed through them remain the same.

NOTE: When using the auxiliary keyboard in OIS mode, ignore the key designators printed on the keys.

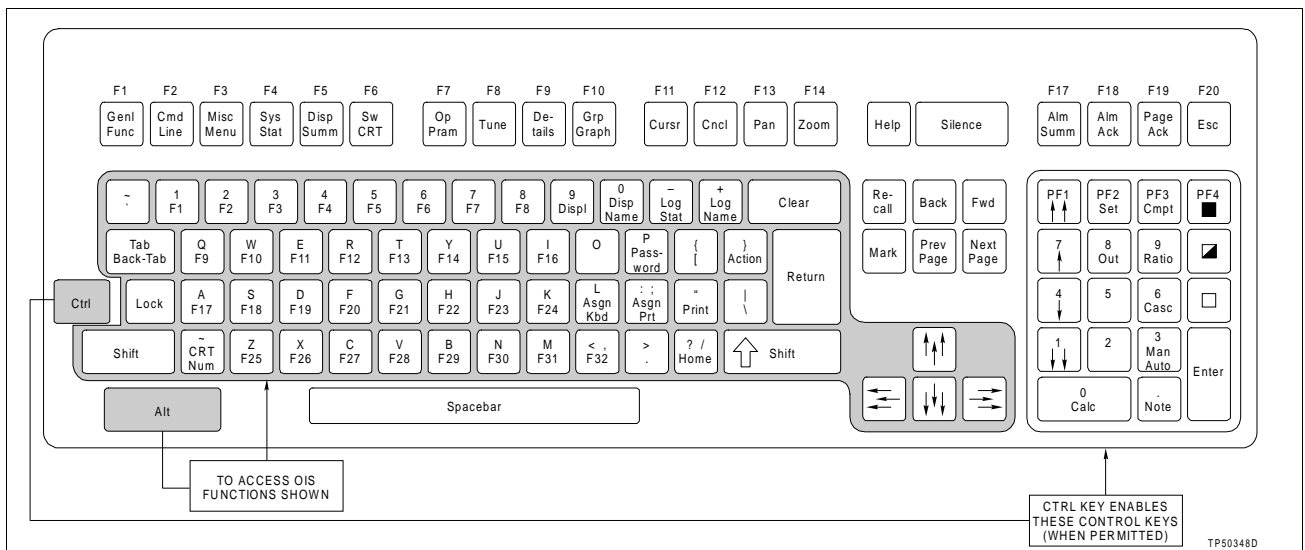

Figure A-1. Key Mapping for the Auxiliary Engineering Keyboard

Depending on the type of keyboard, press **Alt** **Alt Function** or **Compose Character** in conjunction with another key to access the function shown in Figure A-1 for that key (e.g., Home, F1, F2, etc.). For example, to access the Disp (display) function:

Press **Alt** and **9** simultaneously.

Press **Ctrl** in conjunction with a key in the numeric keypad to access the process control function shown for that key. For example, to access the Out (control output) function:

Press **Ctrl** and **8** (in the numeric keypad) simultaneously.

APPENDIX B - ERROR MESSAGES

INTRODUCTION

The messages in this section appear on the screen to give the status of an operator action. Some messages indicate errors, while others prompt for additional information and actions or provide additional information. In the case of a prompt, a response is required before the action can be continued.

ERROR MESSAGES

:ERR 1, Invalid Operation Requested

The attempted operation is not valid for the current display or function. Refer to the appropriate section in the instruction for an explanation of valid operations.

:ERR 2, Value is Out of Range

The entered value is not valid for the current display or function. Refer to the appropriate section in the instruction for valid entries.

:ERR 3, Wrong Set of Keys Being Used

Contact Elsag Bailey.

:ERR 4, No Response to the requested action

Unable to reset the configured RCM tag for the trend pen cluster function. Examine the module configuration (no feedback to the RCM tag).

:ERR 5, Unexpected Key

The key pressed is not valid for the current function. Press another key.

:ERR 6, Invalid Denominator in Input Field

Zero entered as the denominator in the calculator function. Enter calculation with non zero denominator.

:ERR 7, Invalid Input

The input is not valid for the current display or function. Refer to the appropriate section in the instruction for valid entries.

:ERR 8, Shift Times are not in ascending order

Modify logging parameters.

:MSG 9, Display File(s) is/are Being Processed

Informs that display processing has begun while using the display generator. It may take a few minutes for this message to occur if entering a wild card request that satisfies several files. No action required.

:MSG 10, File Not Processed Internal Error

The attempt to process a file failed because of an internal operating system error. Wait a few minutes and try again.

:MSG 11, Log skeleton has been queued for print

Acknowledges request for print of log skeleton. No action required.

:MSG 12, Invalid Tag Entered

1. The tag name or index number entered is not valid or not defined in the database. Enter a valid tag name or index number.

2. The entered tag is not the correct type for the function. Verify valid tag types used by the function.

:MSG 13, Loop failed to respond to the request

Message to database failed for operator control (OC). Retry controlling the tag.

:MSG 14, Gathering tag static data failed

Obtaining static data of a tag from the database failed. Retry controlling the tag.

:MSG 15, Gathering tag dynamic data failed

Obtaining dynamic data of a tag from the database failed. Retry controlling the tag.

:ERR 16, Keyboard # n does not exist

Assigned a window to a nonexistent keyboard. Enter keyboard number that has a physical keyboard.

:ERR 17, CRT # n does not exist

Assigned a keyboard to a nonexistent window or used the number of a nonexistent window. Enter a valid window number.

:ERR 18, Printer # n does not exist

Assigned a window to a nonexistent printer. Enter printer number that has a physical printer.

:MSG 19, All alarms on screen are acknowledged

Pressed an acknowledge alarm key while all alarms currently on the screen are acknowledged. No action required.

:MSG 20, Cannot configure trends, max trends = 0

The number of trends in system configuration is set to 0. Change the number of trends in system configuration to any valid number except zero.

:MSG 21, Invalid action for this type of station

Invalid control key for type of station being controlled. Control the station with proper control keys (OC).

:ERR 22, LEDG can only run on 1 CRT, press ESCAPE

The display generator function is active in another window. Press **ESC** and wait until display is finished in the other window then try again.

:MSG 23, CRT is assigned to keyboard n

Displayed when **SWITCH CRT** is pressed. This appears in the window currently assigned to the keyboard being used. No action required. The keyboard can be reassigned at this time.

:ERR 24, Configuration error

1. Configuration inconsistent for desired action. Occurs when attempting a change to the configuration that is not valid. Check the configuration.
2. Tag type specified in the display is different than in the database. Check the escapes for control in the display source file.
3. This or another configuration is not correct to allow completing the current configuration being performed.

:ERR 25, Cannot use alarm type, limit exceeded

The alarm type selected has a limit which was exceeded. Check other tags for same alarm type.

:ERR 26, Tag name duplicated, see tag n

Tag name already used for another tag. Check tag configuration for indicated tag with same name.

:ERR 27, Blank tag name invalid

A blank tag name or index number was entered. Cannot use blank trigger tag in a currently active SOE log. Enter a valid tag name or index number.

:ERR 28, Tag address duplicated, see tag n

The tag address keyed in is used for another tag. Check tag configuration for indicated tag.

:ERR 29, Valid states are A, H, L, 2H, 2L, 3H, 3L

The alarm state entered was wrong. Enter a valid alarm state. If still wrong, refer to text substitution.

:ERR 30, Cannot enter tag

The tag name is blank but the tag type is not undefined. Either set the tag type to undefined to clear the tag or enter a valid tag name.

:MSG 31, WARNING; ARE YOU SURE? ESCAPE IF NOT

The data entered can delete existing configuration. Press **ENTER** if sure, **ESC** to prevent deletion.

:MSG 32, Update of Files In Progress, Please Wait

As a result of operator interaction, some files are being updated. Wait until the message disappears to continue.

:MSG 33, Restart System, Updates Have Been Done

A change in configuration requires a restart to be used by the console. After completing configuration, reset the OIS application.

:ERR 34, Invalid Log Name/Number Entered

Invalid log identification entered. Retry with the correct log identification.

:ERR 35, Duplicate Log Name Entered

Log name entered has already been used for another log.
Enter a unique name.

:ERR 36, Invalid range, start not less than finish

Range for tags is not valid. Enter a starting index number
that is less than the ending index number.

:ERR 37, Ranges must contain same number of tags

The keyed in ranges have different number of tags. Key in
indexes with proper range of tags.

:ERR 38, Zero is invalid tag index

The tag index keyed in was zero. Enter a valid tag index.

:ERR 39, Invalid display

The display entered does not exist on the hard disk. Enter
the name of an existing display.

:MSG 40, There are no ADPs to configure

No annunciator display panels have been configured in
system configuration. Change the number of annunciator
display panels in system configuration.

:ERR 41, Inconsistent # of Cells and Starting Cell

Number of trend cells overrun the number of cells left in
the column or row. Redefine the number of columns or
rows or redefine the trend cells.

:ERR 42, Inconsistent Time Units

Appears during trend cell definition if an invalid time unit
is specified. Check the definition.

:ERR 43, OIS Configuration Key Locked

Configuration operation requested cannot be used while
the key lock is not in the proper configuration position.
Change the key lock position, then try again.

:ERR 44, LOG is already active or in transition

Log is either active or in transition of being active. Wait for
log to become active.

:ERR 45, LOG is already inactive or in transition

Log is either inactive or in transition of being inactive. Wait for log to become inactive.

:MSG 46, Tag value request failed for LOG no n

Tag request during log collection failed. Check the tag or log configuration.

:MSG 47, Trend value request failed for LOG no n

Trend request during log collection failed. Check the trend definition or log configuration.

:MSG 48, LOG no n is active

Confirmation of log being active. Proceed as desired.

:MSG 49, LOG no n is inactive

Confirmation of log being inactive. Proceed as desired.

:MSG 50, Tag's Primary Display not configured

Operator requested the primary display from the operating parameters page for a tag that does not have one defined. Configure a primary display for the tag if desired.

:MSG 51, Operator Request for xxxx Ignored

Display called up with the maximum number of displays presently up. Check system configuration during start-up.

:MSG 52, No Printer Configured

Use of a system printer requested when no system printers exist. Check the system printer and printer configuration or connect a system printer.

:MSG 58, Alternate Language is not enabled

Access to alternate language configuration is denied. Enter system configuration and change the *Alternate Language* field to YES, then retry.

:MSG 60, End idx must be greater than Start Idx

The start index range must be smaller than the end. Enter new indexes and try again.

:MSG 61, Duplicate definition

1. Indexes entered already exist. Enter new indexes.
2. In alarm summary format configuration (ASF), the alarm summary element that was selected already exists. Select another element.

:MSG 62, Trend is defined but is inactive

The current trend index has been defined in the database but has been marked inactive until restart. No action except restart when trend definition is complete.

:ERR 63, Log must be inactive to reconfigure

Configuring an active log is not permitted. Deactivate the log, then proceed.

:ERR 64, Internal error: Log will not activate

File error on log being configured. Try again. If unsuccessful, delete the definition file for the log, then retry.

:ERR 65, Internal error: Log file/memory error

LOGSTATS.LG or **CRNTLOG.LG** file may be corrupted. Check the files, then retry. They may need to be restored from default files.

:ERR 66, Internal error: Log reset to inactive

Some internal error or file error encountered. Check the **LF** file for the log, then retry.

:ERR 67, Log is in transition Request ignored

Log is awaiting service by the logging data collector (LDC) task to be activated or deactivated. Wait, then retry.

:ERR 68, File Not Found in given directory

The file name entered did not exist in the directory indicated. Enter correct path name or copy the **DT** file to the [DATA.USN54] directory.

:ERR 69, Cannot open storage file WILDCARD.OP

The **WILDCARD.OP** file is a reserved file. Do not try to open.

:ERR 70, No filename entered. Please Continue

Did not enter a file name, which terminated processing. Call up the display generator page again.

:ERR 71, Yellow files with asterisk not processed

One of the wild carded files processed by the display generator had some manner of processing error. When wild carding is complete, examine the files and run them through the display generator individually. File **WILDCARD.OP** contains a list of files with errors.

:ERR 72, Invalid command or syntax within file

The display source file had a bad command, invalid parameters, etc. Examine the file and fix errors.

:MSG 73, Processing Completed

No action required. Proceed as desired.

:ERR 74, Display config'd for another target sys

Run display file through the display generator.

:ERR 75, Problem reading or allocating file

There is a problem with the file being used. Check the file, then retry. If still unsuccessful, delete the file and retry.

:ERR 76, LEDG session tracking file not opened

When a wild card file name is entered, this file is used to keep track of display generator progress. See if there is enough disk space for the file. If the file **WILDCARD.OP** is present, try deleting it before continuing.

:ERR 77, DOT Configuration file not found, created.

The default configuration file will be created. No action required.

:ERR 78, Display/Window not called, over 1600 tags

A display cannot be called if its tag count added to the tag count of all currently active displays exceeds 1,600. Continue to disable any active displays by calling the *General Functions Menu* (or a display with a small tag count) until the desired display can be called.

:MSG 79, Function Under TUNE Keylock Control

The current function is protected by the TUNE key lock. Change the key lock position.

:MSG 80, Function under CONF keylock control

Cannot perform any PCU or console configuration of any kind with the key lock not in the proper configuration position. Change the key lock position.

NOTE: Messages 81 through 116 correspond to interface unit firmware codes 1 to 36. The appropriate reply message displays depending on which error occurred within the interface unit. Check the module that was accessed and its configuration. Refer to the **Hardware** instruction for a list of error codes.

:ERR 81, Reply Error - Waiting for Loop

:ERR 82, Reply Error - Improper Format

:ERR 83, Reply Error - Undefined Command

:ERR 84, Reply Error - Index Already Established

:ERR 85, Reply Error - Block Already Established

:ERR 86, Reply Error - Command Too Long

:ERR 87, Reply Error - Bad Reply from BTM

:ERR 88, Reply Error - Export Used as Import

:ERR 89, Reply Error - CIU Needs Another Restart

:ERR 90, Reply Error - Undefined Index

:ERR 91, Reply Error - Memory Full

:ERR 92, Reply Error - Communication Error

:ERR 93, Reply Error - BTM Not Responding

:ERR 94, Reply Error - Import Used as Export

:ERR 95, Reply Error - Plant Loop Timeout

:ERR 96, Reply Error - Number Out Of Range

:ERR 97, Reply Error - Illegal Key

:ERR 98, Reply Error - CIU Needs a Restart Command

:ERR 99, Reply Error - Module Status Used as Import

- :ERR 100, Reply Error - Message Active on Loop*
- :ERR 101, Reply Error - Import/Export Used as Mod*
- :ERR 102, Reply Error - Exception Report Specs Lost*
- :ERR 103, Reply Error - No Message Queue*
- :ERR 104, Reply Error - Reply Too Large*
- :ERR 105, Reply Error - Illegal Station Mode Command*
- :ERR 106, Reply Error - Illegal Module Number to CIU Problem Report*
- :ERR 107, Reply Error - Timeout Between Bytes*
- :ERR 108, Reply Error - Index Already Established*
- :ERR 109, Reply Error - Point Type Incom. with Command*
- :ERR 110, Reply Error - Watchdog Timeout*
- :ERR 111, Reply Error - Checksum Compare*
- :ERR 112, Reply Error - Destination Node Offline*
- :ERR 113, Reply Error - Callup Command Required*
- :ERR 114, Reply Error - CIU Internal Error*
- :ERR 115, Reply Error - CIU Busy*
- :ERR 116, Reply Error - BTM Offline*

NOTE: Messages 117 through 127 correspond to module bus reply codes 100 to 110. The appropriate messages display depending on which error occurred within the interface unit. Check the module that was accessed and its configuration. Refer to the **Hardware** instruction for a list of error codes.

- :ERR 117, Module Error - Undefined Message*
- :ERR 118, Module Error - Busy*
- :ERR 119, Module Error - Mode Conflict*
- :ERR 120, Module Error - Illegal Data*
- :ERR 121, Module Error - Invalid Block Number*
- :ERR 122, Module Error - Undefined Block Number*
- :ERR 123, Module Error - Block Not Readable*

:ERR 124, Module Error - Invalid Function Code

:ERR 125, Module Error - Blk and F.C. Incompatible

:ERR 126, Module Error - Insuff. Memory for Block

:ERR 127, Module Error - Insuff. Memory for Block

:ERR 128, Communication Timeout Error

Interface unit request reply code 200 returned. Check all communication links between the console and the loop.

:ERR 129, Communication Framing or Parity Error

Interface unit request reply code 201 returned. Check all communication links between the console and the loop.

:ERR 130, Communication Checksum Error

Interface unit request reply code 202 returned. Check all communication links between the console and the loop.

:ERR 131, Communication Overrun Error

Interface unit request reply code 203 returned. Check all communication links between the console and the loop.

NOTE: Error messages 132 through 145 can be seen when attempting multi-function processor or multi-function controller module data file read or write operations.

:ERR 132, MFC File Error - Ok

:ERR 133, MFC File Error - Busy

:ERR 134, MFC File Error - No Buffer Available

:ERR 135, MFC File Error - Buffers Too Small

:ERR 136, MFC File Error - File/Buffer Not Open

:ERR 137, MFC File Error - Write Protected

:ERR 138, MFC File Error

:ERR 139, MFC File Error - Already Opened

:ERR 140, MFC File Error - Invalid Operation

:ERR 141, MFC File Error - Wrong Mode

:ERR 142, MFC File Error

:ERR 143, MFC File Error - File Does Not Exist

:ERR 144, MFC File Error

:ERR 145, MFC File Error - Can't Create File

:ERR 146, Error n has occurred

Generic error message for any unknown error code that is returned from the interface unit. Contact Elsasg Bailey.

:ERR 147, Module is Busy

Operation stopped because module is busy. Try again.

:ERR 148, Loop range is [0 - 250]

Entered value is not in the valid range. Enter a valid number.

:ERR 149, PCU range is [0 - 250]

Entered value is not in the valid range. Enter a valid number.

:ERR 150, Module range is [0 - 31]

Entered value is not in the valid range. Enter a valid number.

:ERR 151, Block range is [0 - 9998]

Entered value is not in the valid range. Enter a valid number.

:ERR 152, Function code range is [1 - 210]

Entered value is not in the valid range. Enter a valid number.

:MSG 153, Loop/PCU/Module must be defined

1. Cannot do requested PCU module configuration operation (POI) while a loop, PCU, and module address is not entered. Define the loop, PCU, and module to be tuned, configured, or inspected.

2. Unable to attain the module hardware address. No action required.

:MSG 154, Module must be in CONFIGURE mode

Cannot do requested PCU module configuration operation while module is not in configure mode. Change module mode to configure.

:MSG 155, Module must be in EXECUTE mode

Cannot do requested PCU module configuration operation while module is not in execute mode. Change module mode to execute.

:ERR 156, Block not defined

Need to specify a block number before an operation involving that block is started. Enter a valid block number.

:ERR 157, Function code not defined

Need to specify a function code value before a search for a block with the given function code is started. Enter a valid function code number.

:ERR 158, Source block not defined

Need to specify a source block before a copy operation is started. Enter a valid source block number.

:ERR 159, Target block not defined

Need to specify a target block before a copy operation is started. Enter a valid target block number.

:ERR 160, Block values may not be equal

Cannot copy a block into itself. Enter a source and target block number that are different.

:ERR 161, Invalid function code

Invalid string entered as a function code value (e.g., alphanumeric string). Enter valid function code number.

:ERR 162, Block already exists

Cannot add a block that is already in the module. Enter a block number that is not currently used in this module.

:ERR 163, No tunable parameters in this block

Block details (BTM) specification list for this function code has no tunable specs. Cannot tune any block with this function code.

:ERR 164, Error while reading 'N90FUNC.CF'

Error reading the data file containing the offset values for referencing the specification configurable text records. Check if the file **N90FUNC.CF** exists on the hard drive or if it is unreadable.

:ERR 165, Block does not exist

Unable to find the specified block defined in this module. Enter a block number that is for a tune or modify operation.

:MSG 166, Press ENTER to send block, ESC to cancel

Confirmation required from the operator before the changed, tuned, or added block is sent to the module. Proceed as desired.

:ERR 167, Destination Format Number not defined

Increase the number of format records in the file by using change number of formats option and try again.

:ERR 168, Requested Tag Is Not Station Type

The tag name or index number entered for a tuning request is not a STATION tag. Enter a STATION tag or examine the configuration.

:ERR 173, Cannot Reserve The Selected Port

A software error. Contact Elsag Bailey.

:ERR 174, Selected Port Already in Use

A software error. Contact Elsag Bailey.

:ERR 175, Module is not On-line

Attempted an operation on a module that is not on-line or does not exist on this loop. Use a module that is on-line.

:MSG 176, Block move is in progress

Moving a block to another location in the module. Wait until message is cleared or replaced.

:MSG 177, Block copy is in progress

Copying a block to another block in the module. Wait until message is cleared or replaced.

:MSG 178, Block operation completed

Appears after completion of a function block copy. Proceed as desired.

:MSG 179, Initializing selected module

Currently initializing the module. Wait until message is cleared or replaced.

:MSG 180, Module initialization completed

Appears after PCU module initialization is complete. Proceed as desired.

:MSG 181, Block # n deleted

Appears after block is deleted from the current module. Proceed as desired.

:MSG 182, Searching for block

Currently searching for the specified block within this module. Wait until message stops blinking and clears.

:MSG 183, Completed n adjusted spec(s)

Displays the number of the specification value within the module that is being automatically changed to reflect the new location of a block that was just moved.

:MSG 184, Processing page n

Current page is being formatted to send to the printer. Wait until the message disappears.

:MSG 185, Operation in progress, Please Wait

Currently requested operation is being performed, wait for completion.

:ERR 186, End of Report, Page to reread problems

No action required.

:ERR 187, Log #n is not active; demand ignored

Demand of current log is ignored because the log is not active. Activate the log, then demand the log after active confirmation.

:ERR 188, Accessing log #n configuration failed

Reading log configuration file failed. Try again. If it occurs again, check the file for cause of file access error.

:ERR 189, Log demand queue is full

Too many outstanding demanded logs (limit is nine). Wait for processing of a demanded log to finish, then try again.

:MSG 190, Processing demand log #n

Identifies the demanded log being processed. No action required.

:MSG 191, Queued demand log #n

Acknowledges queued demand log for processing for a *Log by Name* request. No action required.

:MSG 192, Internal error: Demand log #n failed

Processing of a demanded log failed due to an existing error in the log. Check log configuration and also tag or trend referenced in the log.

:ERR 193, Cannot Continue Processing Request

Generic internal processing error for soft key tag select (SLC). A soft key or hard key request failed. Try the request again.

:ERR 194, Tuning requires a PID block

The function block specified in the tag name or index number is not a PID block. This prompts for PID block address.

:ERR 195, Log Retention is Out of Range

The entered log retention is not in the prescribed range. Enter a valid retention number.

:ERR 196, Tag name/index not found

The tag name or index number does not exist in the database. Check input or tag configuration.

:ERR 197, Invalid trend index (not found)

Contact Elsag Bailey.

:ERR 198, Soft Key Default Parameter Out Of Range

The user-configured soft key parameter was invalid. Check the display source file from which the soft key was called.

:ERR 199, No log Name/Index entered

No log name or index number was entered in the *Log by Name* request so the program ignored the request. Call *Log by Name* again.

:ERR 200, No Display Name entered

No display name was entered in the *Display by Name* request so the program ignored the request. Call *Display by Name* again.

:ERR 201, No Trend Index entered

Contact Elsag Bailey.

:ERR 202, No Log Retention entered

Did not fill in the log retention before pressing **ENTER** in a *Log by Name* request. Fill in the retention and retry.

:ERR 203, Insufficient Parameters to Process

Pressed **ENTER** before all parameters were entered for *Log by Name*, module problem report, tuning, or block details. Fill in all parameters and retry.

:ERR 204, Display Not Found

Display name entered in *Display by Name* request does not exist on disk. Check disk or correct name.

:ERR 205, Log Index/Retention pair does not exist

The supplied retention does not exist for the entered log name or index number. Examine the log configuration or change the name or retention number.

:ERR 206, ABORT: Soft Key Fixed default invalid

A soft key nonmodifiable default parameter was out of range. Correct error in display source file containing soft key request.

:ERR 207, WARNING: Soft Key default invalid

A soft key modifiable default parameter was out of range (initialized by SLC task to zero). Correct error in display source file containing soft key request.

:ERR 208, Error creating EVENTS.LG for n events

Generated by the event log manager (EVL) if a file cannot be allocated for the number of events set during event log configuration. Change the number of events in event log configuration.

:ERR 209, Tag not defined for this index

Could not find a defined tag in the database with this index number. Enter a valid index number.

:ERR 210, Maximum wait time exceeded

SOE log wait time exceeds the maximum allowable wait time (32,767 seconds). Enter a valid wait time.

:ERR 211, Invalid selection for this field

Invalid alphanumeric string was keyed in. Enter a valid string.

:MSG 212, Please Enter PID Block Address

Accompanies the initial display of ERR 194. It asks for an address. Fill in supplied fields.

:ERR 213, Duplicate Address in SP, CO, or PV

Contact Elsag Bailey.

:ERR 214, Maximum Number of Fast Trends Exceeded

Occurs after a tuning display request if the maximum number of fast trends (operator assignable) has been exceeded. Call up the operator assignable trends function and delete a tuning tag.

:ERR 215, Previous Input Field Active

Request aborted because it requires an input field and there is already another input field active in the requesting window. Call a display that has no input field and reissue request or escape from previous field and try again.

:MSG 216, Event Log Queued for Print

Acknowledges the completion of an event log request. No action required.

:MSG 217, SOE Log Queued for Print

Acknowledges the completion of a sequence of events log request. No action required.

:MSG 218, Keyboard # n Reset

A system keyboard has reset. No action required, but a slight pause in system performance will be noticed.

:MSG 219, Specs Not Available Repeat Request later

Tuning request made, but the database has either its process variable or set point low and high values equal. This implies the database specifications for the tag are incorrect. Retry request from 30 seconds to 15 minutes later or check the configuration for the block.

:MSG 220, Request accepted. File search in process

Output by the display generator after entering the file name to process. No action required.

:ERR 221, SOE error # n. See user manual

Error number corresponds to internal communication error codes. Check overall SOE configuration.

:ERR 222, SOE data lost. Check age/wait time config

Wait time in the console is too long relative to the age time set in an MFP or MFC module. Check wait times and overall SOE configuration.

:ERR 223, Problem at SER or with SER/MFC communication

Check overall SOE configuration and connections.

:ERR 224, EVENTS are not defined

Events have not been defined for archiving. Check the *Data Type to Volume Definition* display.

:ERR 225, LOGS are not defined

Logs have not been defined for archiving display. Check the *Data Type to Volume Definition* display.

:ERR 226, TAG DATA is not defined

Tags have not been defined for archiving. Check the *Data Type to Volume Definition* display.

:ERR 227, TRENDS are not defined

Trends have not been defined for archiving. Check the *Data Type to Volume Definition* display.

:ERR 228, Tag name, Tag number, Alarm Group all blank

At least one of these fields must be filled in to retrieve events. Enter valid data in one of the fields.

:ERR 229, Auto Output is YES. ENTER to override

Data type has already been defined to be archived automatically.

:ERR 230, Press ENTER to archive data

Press **ENTER** to continue.

:ERR 231, 'From' date later than 'To' date

Change date entry to continue.

:ERR 232, 'From' log greater than 'To' log

Change log entry to continue.

:ERR 233, Archive Index already defined in display

Contact Elsag Bailey.

:ERR 234, Time value and units mismatch

Combination of value and units not allowed. Check instruction for combinations allowed.

:MSG 236, Substitute by pressing desired State Key

Press one of the state keys to substitute a digital state, or press **ESC** to exit substitution.

:MSG 237, There are no other pages

Pertains to *Operator Action Requests* and *Operator Information Events* display. No more pages of requests or information events to display. No action required.

:MSG 238, Item already selected on CRT n

Pertains to *Operator Action Requests* display. Item being selected is already selected in another display. Select another item.

:MSG 239, Item selected has become unnecessary

Pertains to *Operator Action Requests* display. Action requested for selected item no longer needed or relevant. Item is erased from display. No action required.

:MSG 240, Update to Configuration is Complete

Changes made to configuration have been saved. Proceed as desired.

:ERR 241, Exceeded Maximum Number of Trends

Tried to configure more than 20 fast trends (operator assignable). Delete other trends.

:ERR 242, Exceeded Maximum Number of Blocks Trended

Can trend a limited number of blocks through fast trends and the tuning display. Delete unused fast trends from blocks or the tuning display.

:ERR 243, Cannot Delete Displayed Trend

Trend cannot be deleted while being trended. Terminate trending first.

:ERR 244, File Error Updating Configuration

Updating configuration file failed due to a file management system (FMS) error. Either try again or correct the FMS problem.

:ERR 245, Error Retrieving Tag Configuration

Could be the result of bad tag configuration or FMS file error. Retry or check database and FMS errors.

:ERR 246, High Limit must be Greater than Low Limit

When configuring fast trends, high limit must be greater than low limit. Retry entering limits with correct values.

:MSG 247, No Trend Indices in given list

The soft key request to show a fast trend has no trend index number in it. Check the display file and insure at least one fast trend index is non zero.

:ERR 248, Function not available, missing file

Have requested a soft key or tag select (SLC) function that has been turned off because a system error has occurred. Press another key.

:ERR 249, No Fast Trend List Number Entered

Pressed **ENTER** but did not key in an index number to process for a fast trend request. Enter an index number.

:MSG 250, Log Numbers and Name cannot all be blank

Fill in log number and name.

:ERR 251, Invalid Trend List Number

The trend list number must be zero to four (inclusive). A zero implies a non reference. Check the **DT** file for valid ranges.

:MSG 252, Press ENTER to save page, ESC if not

Prompt to save data or to escape without saving this data. Proceed as desired.

:MSG 253, Cancel reports request serviced

Log status display notifies of completion of a request. No action required.

:ERR 254, Blank Tag is Invalid for Active SOE Rept

Enter a tag name or index number.

:MSG 255, Press ENTER to save data

Configuration has been modified. This prompts to save before exiting. Press **ENTER** to save or another key to exit.

:MSG 259, Press NEXTPAGE or PREVPAGE for more items

Notifies that there are more items that can be accessed by pressing **PREV PAGE** or **NEXT PAGE**.

:MSG 260, Operation aborted by user

Download of the module configuration was canceled by using **ESC**. No action required.

:MSG 261, SELECT a Cell Item from the Menu

Cell type selection mode is active. Choose a cell type for the current cell.

:MSG 262, Press ENTER to delete cells, ESC to abort

Confirms deletion of cells. Press **ENTER** for operation to proceed; press **ESC** to terminate.

:ERR 263, Number of Events to Save must be Non-Zero

Enter a number from 1 to 1000.

:MSG 264, REPORT is already active

A request was made to activate a report that is already active. No action required.

:MSG 265, REPORT is already inactive

A request was made to deactivate a report that is already inactive. No action required.

:ERR 266, LOG/REPORT Type Requested Not Found

There are no logs or reports currently defined for the type requested. Make another selection.

:MSG 267, SEARCH IN PROGRESS

A search request is being processed. Wait for completion.

:ERR 268, LOG/REPORT Does Not Exist

The log or report requested does not exist. Make another selection.

NOTE: Messages 269 through 283 correspond to internally generated errors for the communications interface unit of the console.

:ERR 269, Invalid logical unit

Contact Elsag Bailey.

:ERR 270, Invalid index or CIU

Check total tags in system.

:ERR 271, Invalid CIU restart opt'n

Contact Elsag Bailey.

:ERR 272, Invalid watchdg/delay cnt

Contact Elsag Bailey.

:ERR 273, Invalid PCU, module or blk

Check tag configuration.

:ERR 274, Invalid point type

Check tag configuration.

:ERR 275, Invalid index range

Contact Elsag Bailey.

:ERR 276, Invalid eng. units code

Contact Elsasg Bailey.

:ERR 277, Invalid logical alarm spec.

Contact Elsasg Bailey.

:ERR 278, Invalid module op mode

Contact Elsasg Bailey.

:ERR 279, Invalid function code

Contact Elsasg Bailey.

:ERR 280, Invalid block data count

Contact Elsasg Bailey.

:ERR 281, Invalid number of reports

Contact Elsasg Bailey.

:ERR 282, Offline

Check the interface unit and restart.

:ERR 283, Pending Reply Table Full

If error persists, contact Elsasg Bailey.

:ERR 284, No Tags in Range to Print w/ this Option

Tag list to printer function (TLP) could not find any tags within given range to print with the specified option. Select another print option or a new tag range.

:MSG 285, Operator Action Log Queued for Print

Request to print operator action log has succeeded. No action required.

:ERR 286, Cannot Print Logs to Video Copier

Request to print a log to printer number zero is invalid. Check printer assignment for window and keyboard.

:MSG 287, Height Option not allowed for Line Option

The user selected the double height option for a format which has the single line option specified. If double height characters are desired, change the line option for the format to standard (0) or double (1).

:ERR 288, Cannot Change Default Format (Fmt 0 - 4)

Cannot change format number zero through four. No action required.

:ERR 289, LOG STATUS Changes Require ENTER key

Press **ENTER** to continue.

:ERR 295, Not enough memory. Request Aborted

Operation or display requested cannot be executed because there is not enough memory resources available, for example, the display generator is active in another window consuming much of the memory. Exit unused displays in other windows to release resources and try operation or display again.

:MSG 296, Display not Found in System

Primary display not found in system. After tag is configured, implement the display.

:MSG 297, ESC exits display. Any other key resumes

Informs that **ESC** exits from the cell configuration display back to the log menu.

:MSG 298, Operation aborted, bottom line is in use

Control tried to access the busy bottom line. Escape from using bottom line (input field), try again.

:MSG 299, Parameter edits allowed only if YES FORLANG

Display attributes such as height, spacing, etc., can only be changed after enabling alternate language. Enter **YES** in the *Alternate Language* field on the general parameters page if attributes are to be changed.

:MSG 300, No Data Type to Volume Defined

No data types for archiving have been defined. Check data type to volume definition.

:MSG 301, Press ENTER to exit, ESC to return

Edits were made and have not been saved. Press **ENTER** to abort edits and continue the exit operation requested. Press **ESC** to resume editing.

:MSG 302, Retrieve Archived Data request queued

Retrieve archived data has been requested. Message informs that action has been taken.

:MSG 303, Retrieval queue full -- Please try later

Too many requests have been made to retrieve archived data. Wait for a period of time, then try to send request again.

:ERR 304, Line must be all blanks or filled in

One or more, but not all, of the media type, volume label, or number fields have been filled in. If one is filled in, all must be filled in. Fill in blank fields or blank out all fields.

:ERR 305, Invalid Alarm Group

An invalid alarm group number or letter was entered. A valid entry is 1 through 99, S, or D. Enter valid alarm group.

:ERR 306, Invalid Time or Date

An invalid time or date was entered in the field. Enter a valid time or date.

:ERR 307, All Event Types cannot be set to NO

A request to retrieve events was made with all event types set to *NO*. This is interpreted to mean do not retrieve any events. Change desired event type to **YES**.

:ERR 308, Starting Tag number > Ending Tag number

Starting tag number must be less than or equal to ending tag number. Enter a valid range.

:ERR 309, Starting Alarm Group > Ending Alarm Group

Starting group number must be less than or equal to ending group number. Enter a valid range.

:ERR 310, Install Archive Volume and try again

No archiving volume installed in the device. Put volume in device for desired directory, then try again.

:ERR 311, Retrieve Trends selected. Try again later

Retrieve trends display is only allowed in one window at a time. Wait until the desired window is free, then try again.

:MSG 312, Archiving Configuration change made

Change to archiving configuration has been made. No action required.

:MSG 313, Directory has nothing to be displayed

The requested directory has no entries. No action required.

:MSG 314, Archiving request queued

A store data request was made. No action required.

:MSG 315, Group Inhibit change queued

A request to inhibit or uninhibit all tags in an alarm group was made. No action required.

:ERR 316, Disp. Request Not Operator Configurable

The name of a display that exists in a [DATA.USNxx] directory but does not have an operator configurable display definition file (**CF**) was entered. Enter a different display name.

:MSG 317, Disp. File being constructed, Please Wait

After configuring a display, this message appears to inform that the display is being built. No action required.

:MSG 318, Display Configured and Saved to Disk

When the operator configurable display (OCD) function has finished building the configured display, it outputs this message. If the display is left before this message appears, changes are not saved. No action required.

:ERR 319, Box Overlap, ENTER - accept, ESC reject

A box has been chosen that overlaps an existing box or element. This error message allows accepting or rejecting the new element. Press **ENTER** to accept. Press **ESC** to reject.

:ERR 320, Request Ignored - Active Function Overlap

Function requires exclusive access to the bottom line prompt area. If one is active and another is called, the second request is ignored and this message appears. Press **ESC** then try to recall this display.

:ERR 321, No Faceplate Available for this type

Tag index entered does not have a faceplate associated with its tag type. Enter a tag index that has a faceplate associated with its tag type.

:ERR 322, Changes made. ENTER to save, ESC to Abandon:

Attempted to escape from a display which had been changed. Press **ENTER** to save changes, **ESC** to leave operator configurable displays (OCD).

:ERR 323, Hit ENTER to select box to edit

Informs that **ENTER** must be pressed to select a box to configure in the operator configurable displays function. Press **ENTER** to select a box to edit.

:ERR 324, Trend System Cfg. Error. Tag Type invalid

An attempt was made to get information about a tag from the database that was of unknown type or is not defined. Enter a different trend index or check the trend definition file for valid index, then try again.

:MSG 325, Station Tag, Please Select Trend Tag Type

The selected trend is associated with a STATION tag. Enter one of the following trend box types: PV, SP, RI, or CO.

:MSG 326, Enter printer number

Asks to enter the printer number which is to be assigned to the window. Press the number associated with the printer to assign it to the window.

:MSG 327, Enter CRT number

Asks to enter the number of the window that is to receive the next sequence of keys. Press the number associated with the window.

:MSG 328, Enter display number to RECALL

Asks to enter the number of the previously marked display to recall. Enter number of marked display.

:MSG 329, Enter display number to MARK

Asks to enter the number to be associated with the display when that display is to be recalled by number. Enter number to associate with the display.

:MSG 330, Press ENTER when done selecting else ESC

Asks to press keys associated with a retrieved trend that is to be deleted. Select letters to delete. Press **ENTER** when done or **ESC**.

:MSG 331, Press ENTER to delete page else ESC

Press **ENTER** to delete all retrieved trends on the display or **ESC**.

:MSG 332, Delete Retrieved Trend Files queued

The selected retrieved trend data files have been queued to be deleted. No action required.

:MSG 333, Data Type is ON fill in Volume

If a data type has been turned on to be archived, volume name cannot be left blank. Enter a volume name.

:MSG 334, Data Type previously defined cannot be blank

After the volume name has been defined in the system for a data type, the name cannot be blanked out. Leave the name as is or change to new name.

:MSG 335, X coordinate would cause line wraparound

The x-coordinate entered will cause the element text to exceed the display boundaries. Decrease the x-coordinate so that the element fits within the limits of the blue rectangle.

:MSG 336, DD Mode change invalid while in Remote

MAN/AUTO is locked out if device driver block is in remote mode. When condition goes back to normal, the tag can be controlled.

:ERR 337, Control invalid while Block is Red Tagged

Before and during control of a tag, the red tag status is checked. If red tag status exists, control of the point is abandoned. The tag can only be controlled when the condition is removed.

:ERR 338, Control invalid while in Manual Interlock

Only the control output or set point value can be set when in manual interlock mode. No action required.

:ERR 339, Value Change invalid while in CO Tracking

Setting of control output while in control output tracking mode is not allowed. No action required.

:ERR 340, Value change invalid while in SP Tracking

Setting of set point while in set point tracking mode is not allowed. No action required.

:ERR 341, Press set to enter the value

Press **SET** before entering a value.

:ERR 342, Control invalid while tag in Bad Quality

Before and during tag control, bad quality status is checked. If bad quality exists, control of the point is abandoned. The tag can only be controlled when this condition is removed.

:MSG 343, Enter function to be canceled

Appears after pressing **CANCEL**. It instructs to complete the key sequence by entering a key whose desired function is to be canceled. Press the key of the function to cancel.

:MSG 344, Conversion is needed for log #n

Conversion program for logs created with the console configuration utilities program has not been run. Run the conversion program for logs and try again.

:MSG 345, Log #n is not INACTIVE, request denied

Trying to copy data to a log that is active. Change log to inactive, then try again.

:MSG 346, Printer Queue is Full, Try again Later

The requested print cannot be done. Check printer status.

:MSG 347, First index not printed in request is n

No action required.

:MSG 348, Module firmware revisions queued to print.

Appears from the time that a selection is made to print an entire loop until the print is finished. No action required.

:ERR 349, Destination ring off-line

Satellite ring of INFI-NET system is off-line or not there. Check status of ring.

:ERR 350, Loop and PCU already have a print queued

Appears when a selection to print revision currently on display is made but there is already a print in progress for the same loop and node. Check to see if printer is working. Wait until revision has been printed, then try again.

:MSG 351, Print in Progress. Please Wait

Appears from the time that a selection is made to print an entire loop until the print is finished. No action required.

:ERR 352, Internal Error

Shown when there is an internal software error that may lead to the program not functioning properly. If the error persists after leaving the function and trying it again, contact Eltag Bailey.

:ERR 353, Loop and node must be selected

Shown whenever a request is made to print or update the revisions on display, but there has been no selection of loop and node. Select loop and node and try again.

:MSG 354, File maximum exceed. Delete some files

Appears if the system has more than 25 operator configurable display files. This is just a warning message. No action required.

:ERR 355, Cannot add new file. Too many exist

Appears if attempting to create a new operator configurable display file and there are already 25 files existing. Delete an existing file (check the [DATA.USN53] directory for a list of *.CF file names) or reconfigure an existing file.

:ERR 356, Max. # of background files are on display

A maximum of two background curves may be placed on any given x,y graph. This message displays when attempting to place a third background curve on a graph. Clear the two existing background curves using one of the x,y control options before placement of the new curve is possible.

:ERR 357, Plot must be ACTIVE in order to continue

Message appears whenever an operation is requested that is invalid when the XY plot index is inactive. Activate the plot index through plot definition.

:ERR 358, History request failed

Message appears whenever a request for historical trend data is made for an x,y plot but cannot be completed or displayed. Retry the operation again.

:ERR 359, MFC Error - not enough free memory

Check MFC configuration. Delete extra files. Reformat MFC module.

:ERR 360, MFC Error - no free files available

Check MFC configuration. Delete extra files. Reformat MFC module.

:ERR 361, Floppy Disk Error or missing disk

No action required.

:MSG 363, Limited to one module at a time

Appears whenever an attempt is made to set the mode of a range of more than one module to configure. Set the PCU management (PLS) module range to include one module only, then retry.

:MSG 364, Completed - n config files deleted

Appears at the completion of an operation using option *H* to delete one or more entries of the current configuration file directory. No action required.

:MSG 365, Sorting current directory. Please wait.

Appears whenever a sort of the current file directory is in process during a save operation or during a directory file deletion. Wait until completion.

:MSG 366, Press ENTER to continue, ESC to stop

Displays whenever a verify error occurs. Press **ENTER** to process the next block. Press **ESC** to abort this module operation and proceed to next module.

:ERR 367, File type and module type disagree

Displays during a load, save, or verify whenever the module type within the file is not the same as the actual type of the current module.

:MSG 368, Processing module n, block m

Displays during a load, save, verify, or print. Gives the current module and block being processed. It is updated at every fifth defined block.

:MSG 369, Processing modules n thru m complete

Occurs at the end of every load, save, verify, or print PCU operation.

:ERR 370, Configuration file not found

Error displays during a load, verify, or print whenever the corresponding module configuration file does not exist.

:ERR 371, Address (l/p/m) of file & module disagree

Error displays whenever the hardware address in the configuration file does not match that of the corresponding module.

:ERR 372, File I/O Error 0xnn has occurred.

Contact Elsag Bailey.

:MSG 373, Process BASIC/C for mod n? Y=Yes, N=No

Respond appropriately.

:ERR 374, Verify error - missing file block n

Appears during a module verification if a block in the module is not in the corresponding configuration file. Message number 366 appears alongside this message. Operator action proceeds per message 366.

:ERR 375, Verify error - missing module block n

Appears during a module verification if a block in the configuration file is not in the corresponding module. Message number 366 appears alongside this message. Operator action proceeds per message number 366.

:ERR 376, Verify error - disagreement on block n

Appears during a module verification if a block in the configuration file differs from its counterpart in the corresponding module (e.g., different function codes, different specification parameter values). Message number 366 appears alongside this message.

:MSG 377, Grp Overflow-Up to Tagindex n process

The tag range specified up to the tag index number indicated was processed before the group became full. No action is necessary unless the unprocessed tags are to be added.

:MSG 378, Edits were made - Update Configuration

Any edits made will be lost unless **ENTER** is pressed to save them.

:MSG 379, Historian Group Configuration Updated

Historian group configuration updated after request. No action required.

:ERR 380, Request Error - No RDF name Specified

No RDF name was specified for tag historian retrieval. Enter a valid RDF name and retry.

:ERR 381, Rqst Err - No Wildcard Pattern Specified

A blank wild card pattern to search for is invalid. Enter a wild card pattern and retry.

:ERR 382, Illegal Entry - Tagindex Had Blank Tagname

Tag index entered had a blank tag name which is invalid. Enter a tag index that has a non blank tag name.

:ERR 383, Illegal Entry - Duplicate Tag

Tag entered is already a member of the tag historian group. Enter a tag which is not already in the group.

:MSG 384, Assigned to keyboard n, enter new CRT

Message appears in the new window to which that keyboard is assigned. The numeric parameter to the message will echo the keyboard number from which the operation originated.

:MSG 385, Enter second key in sequence after 'n'

The numeric parameter to the message will be filled in by the number representation of the numeric key press which initiated the key sequence.

:MSG 386, Selected RDF Has Been Queued To Print

Acknowledges request to print selected RDF file.

:MSG 387, Selected RDF Processing Has Been Aborted

Acknowledges request to abort processing an RDF file.

:MSG 388, Selected RDF File Has Been Deleted

Acknowledges request to delete selected RDF file.

:MSG 389, Illegal Selection - Deleted RDF File

An RDF file which has already been deleted was selected from the menu. This is illegal. Select a file which does not have a status of deleted.

:MSG 390, Internal error!! Request ignored.

An internal error occurred while processing the request. This may occur if console software is not current. Retry request and if it continues to occur, contact Elsasg Bailey.

:MSG 391, Illegal Entry; no RDF for Letter Selected

A letter from the RDF directory was selected which did not have a defined RDF file. Select a letter on the menu which has an RDF name defined.

:MSG 392, No Combination was selected. Rqst Ignored

NO was entered for all RDF print formats before initiating request. Answer **YES** to at least one of the formats before initiating a request.

:MSG 393, Retrieval Request Queued

Acknowledges request to retrieve data to create an RDF file.

:MSG 394, RDF file limit reached, Request Ignored

Up to 50 RDF files are available. This message occurs when 50 have previously been defined. Delete existing RDF files before retrying to build a new RDF file.

:MSG 395, RDF file name not unique, Request Ignored.

RDF file names must be unique. Requests to build new RDF files will be ignored if another file with the same name exists. To initiate the request, use a unique RDF name or delete the other file with that RDF name from the RDF directory and then retry.

:MSG 396, Request Rejected - Check File Status

The request was rejected most likely because the RDF file already has a pending process in queue or another window has changed the RDF file status. Exit the RDF directory, then enter to see the RDF file status. Retry the function if appropriate.

:MSG 397, Request Queue Limit Reached, Request Ignored

The request queue to database retrieval is full at this time. Try again later.

:MSG 398, No Items - Key request Ignored

Tried to select an item for which there was nothing to be selected.

:ERR 399, This module types needs a module # of 2

Because of the given module type entered when configuring this tag, the tag address for this tag must have a module number of two. Enter a valid module number.

:ERR 400, This module type needs a module # > 1

Because of the given module type entered when configuring, the tag address for this tag must have a module number greater than one. Enter a valid module number.

:ERR 401, This module type needs a module # < 2

Because of the given module type entered when configuring, this tag must have module number less than two. Enter valid module number.

:ERR 402, Module status tags must have block # of 0

All tags configured with an N90STA tag type must have a block number of zero entered in their tag address. Enter a block number of zero.

:ERR 403, This module type needs a module # of 0

Because of the given module type entered when configuring this tag, the address for this tag must have a module number of zero. Enter a valid module number.

:ERR 404, This module type needs a module # of 3

Because of the given module type entered when configuring this tag, the tag address for this tag must have a module number of three. Enter valid module number.

:MSG 405, FIELD NOT APPLICABLE FOR THIS SYSTEM

The field currently being accessed is not used for this system. Any input will not be used by the system. Go to the next field.

:MSG 406, FUNCTION NOT SUPPORTED FOR THIS SYSTEM

Appears when attempting to access a function not currently supported on this system.

:MSG 407, Enter Tag Name or Index

Prompt to enter a tag name or an index number.

:MSG 408, Saving Configured Data ...

Informs that the configuration is being saved. Do not perform any other actions until the message disappears.

:MSG 409, Test in Progress

Informs that the requested test is being run. If the test is to run until completion, do not perform any other actions until the message disappears. Press **ESC** to terminate the test immediately.

:MSG 410, Physical Device Overlap

During the configuration of relays, informs that the entered relay or keyboard value would cause overlapping use of a physical relay. The offending relay or keyboard value should be entered in a manner such that it does not cause an overlap of a physical relay.

:MSG 411, Bad Logical Relay Value

During the configuration or testing of relays, informs that the entered logical relay number does not exist. Enter a legal logical relay number.

:MSG 412, Bad Physical Relay Value

During the configuration of relays, informs that the entered physical relay number does not exist. Enter a legal physical relay number.

:MSG 413, Bad Keyboard Value

During the configuration of relays or tones, informs that the entered keyboard number does not exist. Enter a legal keyboard number.

:MSG 414, Bad Time Duration Value

During the configuration or testing of relays or tones, informs that the entered duration value (in seconds) is not legal. The duration is too long or too short. Enter a legal duration value.

:MSG 417, Bad Logical Tone Value

During the configuration or testing of tones, informs that the entered logical tone number does not exist. Enter a legal logical tone number.

:MSG 418, Bad Priority Value

During the configuration of tones, informs that the entered tone priority value is not legal. The priority is too high or too low. Enter a legal tone priority value.

:MSG 419, Bad Pitch Value

During the configuration of tones, informs that the entered tone pitch value is not supported. Enter a legal tone pitch value.

:MSG 420, Bad Volume Value

During the configuration of tones, informs that the entered tone volume value is not legal. The volume is too high or too low. Enter a legal tone volume value.

:MSG 421, Bad Broadcast Entry

During the configuration of tones, informs that the string entered to confirm tone broadcasts is incorrect. Enter a **YES** or a **NO**.

:MSG 422, Bad Node List Value

During the configuration of tones, informs that the entered node list number does not exist. Enter a legal node list number.

:MSG 423, Software failure, please restart console

Message is seen as an operator actions request (i.e., flashing A). It occurs when a program task is not operating. Enter the operator action request function and initiate actions to restart the console.

:MSG 424, OPTION NOT AVAILABLE ON THIS SYSTEM

The option being attempted is not supported on this system.

:MSG 425, Same MKI/EMKI assigned to different nodes

A node can have only one keyboard assigned. The node name being entered already has an assigned keyboard. Enter a node name that does not have a keyboard already assigned.

:ERR 426, Insufficient user access rights

Currently logged in user does not have sufficient access rights to the selected function as defined through password security configuration.

:ERR 427, Unauthorized access attempted

Currently logged in user attempted to access a function without having sufficient access rights to the function as defined through password security configuration.

:ERR 428, Error Modifying RT. ENTER to rtry, or ESC

This indicates that some error which prevents completion of a red tag status change has occurred. Typically, this is an INFI 90 OPEN loop or module communication error. View the diagnostic log to determine the module or loop error which has occurred.

:ERR 429, Display access restricted on this CRT

Currently logged in user does not have sufficient display access rights to the selected display as defined through password security configuration or during display creation.

:MSG 430, Plot is not of MFC Data Source Type

Appears on an XY plot display when attempting to redefine a tag or trend plot currently on that display as an MFC data source plot. This only occurs while the XY plot is displaying in one window and the XY plot definition page is displaying in another window at the same time. Disable the XY plot display before attempting to redefine a plot as an MFC type.

:MSG 431, No Assignment Possible--one system CRT

When attempting to assign a keyboard to a window, this informs that the console has only one window; therefore, the attempted keyboard assignment is invalid.

:MSG 432, Not All Tags ACKED

When using **PAGE ACK** to acknowledge alarms, not all alarms on the current page have been acknowledged. This occurs when the currently logged in user does not have sufficient access rights to acknowledge an alarm for a certain tag or tags on that page.

:MSG 433, Insufficient access to ACK

Occurs when the currently logged in user does not have sufficient access rights to acknowledge an alarm (using **ACK ALARM**) for a selected tag.

:MSG 434, No Access to TAB

Occurs when the currently logged in user does not have sufficient access rights to acknowledge an alarm condition for a tag. The user cannot tab to the tag after pressing **ACK ALARM**.

:ERR 435, Log In Failure--Password Not Found

Password entered during password log-in is not defined in password security configuration. Verify the password is valid and try again.

:ERR 436, CRT Access Denied--Insufficient Rights

Currently logged in user does not have sufficient display access rights to the selected display as defined through password security configuration or during display creation.

:ERR 437, Alarm Inhibit Mode conflict at tag n

Occurs when attempting to redefine a tag that is being used to inhibit alarming for another tag or tags. The tags being inhibited by this tag must be modified before this tag can be redefined.

:ERR 438, Tag Update Failed - Duplicate Tagname

The tag change requested causes a duplicate tag name conflict. In this case, there is already a tag with this name but having a different address. Change the tag name and retry.

:ERR 439, Tag Update Failed - Duplicate Address

The tag change requested causes a duplicate tag hardware address conflict. In this case, there is already a tag with this address but having a different name. Change the tag address and retry.

:ERR 440, Tag Update Failed

A general error message. It is most frequently due to the GDM work station not being on-line or a failure in the communication system exists. Make sure the work station is on-line and that the node address configured in the *Broadcast Master* field is correct. Consult the **stb.log** file on the work station for additional information.

:ERR 441, Tag Broadcast Failed, Local update only

Appears when a tag database change is made to identify that tag broadcasting is in local mode only. In this mode, a tag list broadcast can be received from a GDM work station, but changes made from the console are not broadcast to the work station. Any changes made from the console do not affect the GDM tag database. The change is, however, made locally to the console tag database.

:ERR 442, Copy of 'blank' tag to tag n illegal

The type for the tag being copied is UNDEF. A tag defined as an UNDEF type cannot be copied to another index. Only defined tags (any tag type except UNDEF) can be copied.

:ERR 443, Invalid Copy attempt, 'blank' source tag

The type for the tag being copied is UNDEF. A tag defined as an UNDEF type cannot be copied to another index. Only defined tags (any tag type except UNDEF) can be copied.

:MSG 447, Tag Update Failed - GDM broadcasting tag

The GDM program has a rebroadcast pending on this tag. Wait for the rebroadcast to complete and retry.

:MSG 448, Tag Update Failed - Ident.Console differs

A tag exists in one identical console but not in another. The consoles have become out of synchronization. Refer to the **Software Global Database Manager** instruction for additional information.

:MSG 449, Tag Update Failed - Existing tag mismatch

An attempt was made to add a tag that exists in another console without matching all of the common tag fields. Make all common tag fields in the tag being added identical to the fields of the existing tag. Refer to the **Software Global Database Manager** instruction for additional information.

:MSG 450, Tag Update Failed - Tag not in GDM to del

An attempt was made to delete a tag that is not in the GDM database for this console. The program has become out of synchronization with the console. Add the tag to the GDM database by calling it up on the console and pressing **ENTER** to save. Then retry the delete.

:MSG 451, Tag Update Failed - Tag indx out of range

Occurs when a tag is added from another console that has a larger tag database than this console. The GDM program has attempted to add the tag to this console at an index number that is invalid for the console.

:MSG 452, Tag Update Failed - GDM move index error

While the console was in local broadcast mode, a tag was deleted and entered at a new index number. The GDM program has become out of synchronization with the console. Enter the tag name and address in the original index location, then delete it. At the new index, press **ENTER** to save the tag at its new index and to update the GDM database.

:MSG 453, Tag Update Failed - GDM taglst not loaded

No tag list loaded in the GDM program for this console. Load the tag list.

:MSG 454, Tag Update Failed - GDM has duplicate tag name

Informs that the GDM database contains tags with the same name.

:MSG 455, Event and error counters were reset

Indicates that the request to reset the event and error counters for the selected node or nodes was successfully completed.

:ERR 456, Failed to reset event and error counters

Indicates that the request to reset the event and error counters for the selected node or nodes has failed. In most cases, this indicates that a node is off-line or in error. Use an INFI-NET diagnostics function to check the status of the selected node or nodes.

:MSG 457, Exception statistics were reset

Indicates that the request to reset the exception statistics for a selected node or nodes was successfully completed.

:ERR 458, Failed to reset exception statistics

Indicates that the request to reset the exception statistics for the selected node or nodes has failed. In most cases, this indicates that a node is off-line or in error. Use an INFI-NET diagnostics functions to check the status of the selected node or nodes.

:MSG 459, Assigned to Events Logs, cannot be shared

This occurs when attempting to change a printer assignment from private to shared for a printer used to print a continuously printing event log (i.e., events print as they occur). Printers used for a continuously printing event log cannot be shared. Either use a different printer or reassign the event log to print to a different private printer.

:MSG 460, Assigned to Action Logs, cannot be shared

This occurs when attempting to change a printer assignment from private to shared for a printer used to print a continuously printing actions log (i.e., operator actions print as they occur). Printers used for a continuously printing actions log cannot be shared. Either use a different printer or reassign the actions log to print to a different private printer.

:MSG 461, Assigned as Shared, must be a Private prt

This occurs when attempting to assign a shared printer as the logical printer for a continuously printing events or operator actions log while in the event log configuration function. Assign a private printer as the event or operator actions log logical printer or change the printer assignment to private.

:MSG 462, Unable to open window on requested node

During X device definition, a node is checked before assigning a window to that node. Either the node name being entered is invalid or the node is off-line. Enter a valid node name or verify that the node is on-line.

:ERR 463, Output option must be PRINT or DISPLAY

The options for the *Print/Display* portion of the input field called by selecting *Log by Name* are **PRINT** or **DISPLAY** only. Enter either of these.

:MSG 464, Function not valid for media type OAS

Occurs when trying to retrieve log or event data from an open access system (OAS) media type or trying to *Use New Volume* for an OAS media type. Retrieving data from an open access system is not supported and the *Use New Volume* option does not allow for the OAS media type.

:MSG 465, Only logs/events valid on media type OAS

When defining archival storage, an attempt to archive either tag, trend, or PCU configuration data types to open access system media type was made. Only logs and events data types can be archived to open access system media type.

:MSG 466, Maximum or Minimum Zoom reached

Appears if the requested zoom on a trend exceeds the display resolution. This occurs when an attempt is made to zoom a trend display past its maximum or minimum resolution.

:ERR 467, Maximum number of save to disk configured

Informs that the maximum number of save to disk trends have been configured while performing trend definition. No additional save to disk or archiving trends can be added.

:MSG 468, Enter YES or NO

Informs that a **YES** or **NO** response is required to continue.

:MSG 469, Time change request has completed

Appears after processing of a time change request is completed.

:ERR 470, Console's time has not been synchronized

Appears when the operator requests a change to the local (wall-clock) time before the console begins processing time-sync messages. This can occur during approximately the first nine minutes after a console starts up. The local time on the console will update, but the time will not be updated on the loop. Wait a short period of time and try the change request again.

:ERR 471, Console's time has not been synchronized

Appears when the operator requests a change to GMT time (system time) before the console begins processing time-sync messages. This can occur during approximately the first nine minutes after a console starts up. Wait a short period of time and try the change request again.

:ERR 472, Internal error processing time request

Some internal error occurred that does not allow the console to process a time change request. Reset the OIS application and attempt the request again. If this does not work, contact Eltag Bailey.

:ERR 474, Greenwich Mean Time is not established

A time maintenance option has not been used to initialize time synchronization for the console and to establish GMT time. Choose any of options *D* through *F* of the *Set Date and Time* function to initialize time synchronization before attempting to change the local (wall-clock) time. This is required on all consoles on the loop at least once after start-up to initialize time synchronization.

:ERR 476, Cannot change GMT before synchronized

An option was selected that allows the console to update its time based on the loop time, but the loop has not been synchronized. Choose an option from the *Set Date and Time* function that establishes GMT time (system time) for the loop.

:ERR 477, Error in formula definition

During custom log cell definition, a formula was entered incorrectly.

:ERR 478, Invalid cell type in formula definition

An address of a cell that is not valid for the formula cell function was entered. Refer to the formula cell option page to identify valid cell types.

:ERR 479, Not enough operands in the formula definition

At least two operands must be entered for a formula definition.

:MSG 480, No data from the module for plot index n

If a data file has not been received for an MFC data source plot, the display remains blank and this message appears until the data has been read from the module.

:MSG 481, Archival not allowed, Trend must be LOCAL

A remote trend has been designated for archiving. Only local trends can be archived. The open access system can be used to archive remote trends.

:MSG 482, Only Terminal Server printers can be Shared

A printer connected to an auxiliary console cannot be a shared printer. Only a printer connected through a terminal server can be designated as shared. Either make the printer a private printer or select a network printer to be the shared printer.

:ERR 483, User task activation node name too long

The node name is limited to six characters. Either the node name specified during user task definition is too long or the logical name is defined with an incorrect node name. Check the user task definition or the logical name if used.

:ERR 484, User task activation node not on network

The node indicated in the user task definition function or the interactive escape command in the display source file is invalid. Verify the network node name for the UTI server and check the node name used in the user task definition or display interactive escape.

:ERR 485, User task activation server not running

The user task interface is not running on the server node. Check the server node.

:ERR 486, Unable to connect to activation server

This indicates a network error. Check the diagnostic log to determine the cause of the network error.

:ERR 487, User task activation server busy

The user task interface server node cannot process any additional user task activations. Either wait for some user tasks to deactivate or deactivate some user tasks before attempting to activate another task.

:ERR 488, Error sending activation message

This indicates a network error. Check the diagnostic log to determine the cause of the network error.

:ERR 489, Error receiving activation reply

This indicates a network error. Check the diagnostic log to determine the cause of the network error.

:ERR 490, Invalid user task name

The user-written program does not exist on the specified node. Verify the network node name for the UTI server is correct in the user task definition function or in the display interactive escape. Check the server node to determine if the task exists.

:ERR 491, Duplicate user task process name

This only occurs for tasks activated with the *CREATE* method of activation. The message appears when the task selected for activation has already been activated previously and an attempt to activate it again has been made.

:ERR 492, Error reading user task definition file

The configuration of an ADP pushbutton or keyboard function key references an invalid user task index number. Check the ADP pushbutton or keyboard function key configuration or the user task definition. Check the diagnostic log to determine the cause of the error.

:MSG 493, User task activation queued

This informs that the activation request made from the console has been processed successfully. This message should be followed by another, either a response from the user task interface that the task has been activated or some error message to indicate the activation was not successful.

:ERR 494, User task activation internal error

Some internal error occurred. Check the diagnostic log to determine the cause of the error.

:MSG 495, User task activation successful

This is a response from the user task interface that the activation of a user task was successful.

:ERR 496, Control Invalid While in String Interlock

Control actions cannot be performed from a TEXTSTR element while *USER TEXT LOCK* appears in the element. The control configuration has been set to not allow input from the console.

:ERR 497, Response Is Invalid For Current Prompt

A mismatch between the current prompt or question appearing in a TEXTSTR element and a response to the prompt or question has occurred. Enter a new response to the current prompt or question.

:ERR 498, Control Has Not Been Enabled

A TEXTSTR element cannot be selected for control if the *Control Enable* field for the tag is set to *NO* in the tag database.

:ERR 499, WARNING - External Source Index undefined

Appears when defining a trend and an index number for an external source node is entered that is not defined through OAS definition.

:MSG 500, Press ENTER to accept, ESC to edit again

Prompts to press **ENTER** to update the configuration or to press **ESC** to return to editing.

:ERR 501, Same display on CRT n cannot change plot

If the same MFC data source XY plot display is called in a different window, changing plot index is not permitted. If an attempt is made to change the index, this message appears.

:ERR 502, Plot already on display

Up to three MFC data source plots can appear in one window at a time. If the entered plot index is already displaying in the current window, this message appears.

:MSG 503, Verifying module n, block n.

Indicates the status of a verify configuration operation. This message appears when using PCU management functions.

:MSG 504, Error encountered at module n.

Indicates that an error condition exists in a module. This message appears when using PCU management functions.

:MSG 505, PCU CONFIG Data is not defined.

There is no PCU configuration data to archive.

:MSG 506, Block n is the last defined block.

Gives the address of the last function block defined in the current module. This message appears when using PCU configuration functions.

:ERR 507, Error calling display - - cache fragmented

Call up the *General Functions Menu* in all windows to clear the display cache, then try to call up the display again.

:MSG 508, TASK EXITED

Explicitly notifies that the current task has been exited.

:MSG 509, Tag n access DENIED

Indicates that the current user does not have sufficient security access to call the tag.

:MSG 510, USER ONLY HAS VIEW ACCESS RIGHTS

Indicates that the current user has monitor security access rights only.

:ERR 511, Red Tag Key Invalid

The red tag key input field is blank or has invalid characters. Enter a valid three-character key, then try again.

:ERR 512, Red Tag Note required for operation

A red tag note is required when performing any set or remove operations with the red tag status function. Enter a note, then try again.

:ERR 513, Red Tag Key to be REMOVED not defined

The red tag key being entered is not set for the function block. Refer to the *KEY* fields on the red tag status page to view the keys currently set for the function block.

:ERR 514, Block not valid for Red Tag Operations

The function block being called does not support red tagging.

:ERR 515, Duplicate Red Tag Key or all Keys set

The key that is being entered is already set or three keys are already set for the function block. Setting duplicate keys for a function block is not permitted. Also, the function block allows for only three keys.

:MSG 516, CRT Ovrld to n, enter crt or 0 to cancel

Identifies the current override window and allows reassigning or canceling the override assignment. Enter the number of another window to make a new assignment, or enter **0** to disable the override.

:MSG 517, CRT Ovrld has been disabled

Verifies that a previous override assignment has been canceled and that no override condition currently exists. No action required.

:MSG 518, CRT Ovrld assigned to n

Verifies an override assignment. No action required.

:MSG 519, Crt n disabled till System Restart

Occurs when attempting to make an override assignment after a system configuration change has been made that requires an OIS application. Reset the OIS application, then try the assignment again.

:MSG 520, PLEASE SET GMT FOR FUNCTION TO WORK

Informs that GMT time must be set before the function can be used. Set GMT time by using the *Set Date And Time* function.

:MSG 521, Press ENTER to initiate control action

Enabled when *Control Acknowledgment Required* is set to **YES** on the general parameters page. When enabled, pressing **ENTER** is required before any control changes are put into effect.

:MSG 524, Reset console for change to take effect

Indicates that the change made to the current page will not take effect until the OIS application is reset. Other operations or configurations, however, can still be performed before resetting.

:MSG 525, System startup in progress. Retry later.

Appears when attempting to call an interactive display before system initialization completes. Completion can be identified by the *System Initialization Complete* message appearing in the message window.

:MSG 526, LOCAL Transport requires Server Node '0'

To use LOCAL as the window network transport type during X device definition, the server node must be set to 0.

:MSG 527, Server name too long for DECNET or LAT

The DECnet and LAT node names are limited to six characters.

:ERR 532, Control invalid while Block is No Report

The tag cannot be controlled while the block is in a no report condition. No report means the block is not sending exception reports. Use the operating parameters function to enable reporting.

:ERR 533, Control invalid while tag is Substituted

The tag cannot be controlled while the block has a substituted value or state. When a tag has a substitute value or state, it is disestablished (scan off). Use the operating parameters function to disable substitution.

:ERR 534, Control invalid while tag Disestablished

The tag cannot be controlled while the block is disestablished (scan off). Use the operating parameters function to establish the tag (scan on).

:ERR 535, Control inhibited for x

The tag cannot be controlled due to an inhibit condition for the block. The control logic or some other supervisory device must uninhibit the block before control is allowed.

:MSG 537, Press ENTER to initiate x control

Prompts to press **ENTER** to initiate the control action.

:ERR 543, Control invalid, x in Bad Quality

The tag cannot be controlled while the block is reporting bad quality.

:MSG 544, x Remote Screen Copy server is busy

There are already two screen copies active on the indicated node. Wait until a prior screen copy completes.

:ERR 545, x Remote Screen Copy node undefined

The indicated node is not in the network database. Check the network configuration and verify proper X device definition.

:ERR 546, No Remote Screen Copy Server on x

There is no screen copy server task on the indicated node. Check the node status and verify proper X device definition.

:ERR 547, x Screen Copy Server connect failure

Error encountered while attempting to connect to the screen copy server task on the indicated node. Check the node status and verify proper X device definition.

:ERR 548, x Screen Copy Server message aborted

Error encountered while sending a message to the screen copy server task on the indicated node causing the print request to be aborted. Check the node status.

:ERR 549, x Screen Copy Server discnct failure

Error encountered while attempting to disconnect from the screen copy server task on the indicated node. Check the node status.

:ERR 550, x Remote Screen Copy capture failure

The screen copy task on the indicated node encountered a VMS error while capturing an OIS window prior to printing. Check the node status and network configuration.

:ERR 551, x Remote Screen Copy wake-up error

The screen copy server task on the indicated node encountered a VMS error while attempting to activate the remote screen copy task. Check the node status.

:ERR 552, Duplicate RSCT process name on x

The screen copy server task on the indicated node could not activate an instance of the screen copy task because a prior, supposedly terminated instance is still active. Check the node status.

:ERR 553, Error creating RSCT process on x

The screen copy server task on the indicated node encountered a VMS error while attempting to create an instance of the screen copy task. Check the node status.

:ERR 554, No RSCT executable image on node x

The screen copy server task on the indicated node could not find the executable image file for the screen copy task. Check the node status.

:ERR 555, x Remote Screen Copy print failure

General error indicating a failure of screen copy processing. Check the node status.

:ERR 556, No Printer Config received on node x

The screen copy server task on the indicated node did not receive a printer configuration from the print configuration task. Verify the print configuration window is available on the indicated node.

:ERR 557, Unknown RSCT process on node x

The screen copy server on the indicated node cannot identify the screen copy task that is requesting printer configuration information.

:ERR 558, x RSCT unable to connect to server

The screen copy task on the indicated node encountered an error connecting to the X window server on the originating node.

:ERR 559, x RSCT invalid device type error

The screen copy task on the indicated node determined that the device type for the requested print operation is invalid. Check print configuration and queue names.

:ERR 560, x RSCT file processing error

The screen copy task on the indicated node encountered a file I/O error while processing a print request. Check the node status.

:ERR 561, x RSC invalid printer type error

The screen copy task on the indicated node determined that the printer type for the requested print operation is invalid. Check print configuration.

:ERR 562, x RSC error queuing file for print

The screen copy task on the indicated node encountered a VMS error while queueing a file for print. Check print configuration and queue names.

:ERR 563, x RSC error reading X-Window data

The screen copy task on the indicated node encountered an error while reading X window data from the originating node.

:ERR 564, RSC failover on x, job #n

Screen copy printer failover on queue x, job number n. Check the printer assigned to queue that failed over.

:ERR 565, RSC job #n deleted on x

Dead end encountered during screen copy printer failover processing and the associated job number n has been deleted on queue x. Either there is no backup queue configured for the printer to which the job is currently queued or the original target printer has been selected again during failover processing. Files are only deleted if the *Discard Prints when Dead-End Encountered* option is enabled.

:ERR 566, RSC job #n stalled on x

Dead end encountered during screen copy printer failover processing and *Discard Prints when Dead-End Encountered* option is not enabled. The print job will remain queued on the indicated printer. In this case, the dead end is because there is no backup queue configured for the printer to which the job is currently queued.

:ERR 567, 4.5mm not compatible with Alternate Lang.

4.5 millimeter characters cannot be enabled when alternate language is enabled.

:ERR 568, PRIVATE to SHARED failover not permitted

A private printer cannot be defined to failover to a shared printer. Check printer assignment and peripheral failover configurations.

:ERR 570, More than 20 tags in popup.

A maximum of 20 tags can be referenced in a symbol file called as a pop up using **ei 107,91** or **ei 108,91**. If this message appears, the first 20 tags in the pop up with the lowest index numbers will update dynamically. Any additional tags may have an initial value displayed or indicated but the value will not update. To correct this error, specify a single or less than 20 tag indexes in the pop up. Specify a dummy tag index other than zero in all **es** and **ed** commands used in the pop up. This index number will be substituted during display generation with the index number defined in **ei 107,91** or **ei 108,91**.

:MSG 571, Reselect control element

Control element not selected. Try again.

:MSG 572, Duplicate; tones must be unique

The logical tone assigned as the alarm tone and return-to-normal tone of alarm priorities must be unique. Tones must be unique for tone prioritization purposes.

:MSG 573, Restart console to establish change

Indicates that the change made to the current page will not take effect until the OIS application is reset. Other operations or configurations, however, can still be performed before resetting.

:MSG 574, Priority's Primary Display not configured

The alarm priority pushbutton did not call a display because a display was not assigned to the priority during alarm priorities configuration.

:MSG 575, DISPLAY MUST BE re-BUILT FOR TRENDS

Indicates that trend displays need to be rebuilt. Use the display generator.

:MSG 576, Activating SmartLink

Confirmation of SmartLink activation request made from console. Proceed as desired.

:MSG 577, SmartLink Activation is not enabled

This informs that the activation request from the console was not successful. Required to have both SmartLink optional software installed and SmartLink enabled on the System Configuration page.

:MSG 578, Control Is Disabled From Pointing Device

This informs that the control from pointing device option is disabled. Requires enabling in order to use defined touch points on display.

:MSG 579, Error - Central Repository is Offline

Indicates that the central red tag information repository MFP is in one of the following modes: off-line, error, or config. Place MFP in execute mode.

:MSG 580, Remove Red Tag Key from Block (Y/N)?

Indicates that the central red tag information repository MFP is in one of the following modes: off-line, error, or config. A yes response will remove the red tag key from the block but not from the central red tag information repository.

When the central red tag information repository is back on-line, and the tag is called up on the Red Tag Status screen, the red tag key will be removed from the central red tag information repository.

:MSG 581, Red Tag Manager Busy, Try Again Later

Indicates that the central red tag information repository is busy and is unable to handle additional requests. Wait a few minutes and try again.

:MSG 582, Error - Invalid Repository Msg Received

Problem has occurred on central red tag information repository MFP. Record error number and contact Elsag Bailey.

:MSG 583, Repository Error %d Setting Key

Problem has occurred on central red tag information repository MFP. Record error number and contact Elsag Bailey.

:MSG 584, Repository Error %d Removing Red Tag Key

Problem has occurred on central red tag information repository MFP. Record error number and contact Elsag Bailey.

:MSG 585, Repository Error %d Retrieving Key

Problem has occurred on central red tag information repository MFP. Record error number and contact Elsag Bailey.

:MSG 586, Timeout Error Waiting for Repository

Indicates that central red tag information repository MFP is not responding to requests. Wait a few minutes and try again. If message reappears contact Elsag Bailey.

:MSG 587, Set Red Tag Key in the Block (Y/N)?

Indicates that the central red tag information repository MFP is in one of the following modes: off-line, error, or config. A yes response will set the red tag key in the block but not in the central red tag information repository.

When the central red tag information repository is back on-line, and the tag is called up on the Red Tag Status screen, only the red tag key will be displayed on the screen, since no red tag key information was stored in the central red tag information repository.

:MSG 588, No Replies for This Query

Indicates that the central red tag information repository does not contain any information on a particular red tag query.

:MSG 589, Requested Build of S.F.D. Address File

Confirmation of Build SmartField Device Address File activation request made from console. Proceed as desired.

:MSG 590, @aGlance/IT Task Activation NOT Enabled

Indicates that @aGlance/IT is not active. Access User Task Options menu to enable @aGlance/IT. Requires reset of console.

:MSG 591, Startup Data Modified, Restart Console

Indicates that the console must be reset in order for modifications to the Use UTI Instead of @aGlance/IT and/or @aGlance/IT Server name selections on the User Task Options menu to take effect.

:MSG 592, @aGlance/IT Server Name too Long

Indicates that the server name is longer than the allowable 32 characters. Requires that server name be shortened.

:MSG 593, @aGlance/IT NOT Supported on This System

Indicates that console does not support @aGlance/IT operations.

:MSG 594, UTI User Task Activation NOT Enabled

Indicates that UTI is not active. Access User Task Options menu to enable UTI. Requires reset of console.

MSG 595, Control Invalid for STD I/O Type

Indicates that control actions are invalid for a standard I/O type tag.

MSG596 Override Not Permitted for this Tag

Indicates that the Override function is not permitted for this tag.

MSG597 Can not substitute while control active

Indicates that the control for a tag is open while the substitute function is being used. Close the control window then try the substitution again.

MSG598 Bottom Line Prompt Invalid for this Tag

Indicates that the Bottom Line Prompt function is invalid for this tag.

MSG599 Local Trend Display Scale change

Indicates that there has been a trend scale change to the **.DU** file on the local node.

MSG600 Global Trend Display Scale change

Indicates that there has been a trend scale change to the **.DU** file from the network.

Index

A	
ACK ALARM.....	12-13
Alarm summary.....	12-19
System status.....	21-13
Alarm	
Acknowledge.....	12-12
Alarm group.....	12-4
Alarm suppression.....	12-10
Alarm tone silence.....	12-11
Correcting.....	12-13
External annunciator silence.....	12-12
Indications.....	12-1
Indicators.....	12-4
INFI 90.....	12-3
Manual inhibit.....	12-19, 13-9
Priority descriptors.....	12-9
Priority indicators.....	4-6, 12-8
Process.....	12-3
Processing.....	12-10
Re-alarmed.....	12-9
Status field.....	12-4
Summary.....	12-14
Attributes.....	12-15
Element.....	12-16
Line attributes.....	12-15
Operations.....	12-17
Primary display.....	12-19
Return to normal.....	12-14, 12-19
Sorting.....	12-14
System status alarms.....	12-14
System status.....	21-12
Title line.....	4-4, 12-8
ALARM SUMM.....	12-17
ALT LOCK.....	4-8
Alternate language	
Data input.....	7-5
Keyboard mode.....	4-8
Analog	
Annunciator element.....	10-6
Standard element.....	10-6
Annunciator display panel	
Accessing displays.....	7-7
Description.....	1-5
Operation.....	3-11
Archiving.....	19-1
Action request.....	19-24
Archival error.....	19-25
Configuring data to archive.....	19-15
Data retrieval.....	19-25
Data storage.....	19-2
Data types.....	19-2
Description.....	19-1
Directory of archive volume.....	19-26
Directory of retrieved data.....	19-41
Medium.....	19-1
Open access system.....	19-6
Scheduling.....	19-11
Store data option.....	19-21
Tag historian.....	19-17, 19-46
Use new volume option.....	19-23
Viewing or printing retrieved data.....	19-45
Automatic displays.....	7-8
Activating.....	7-9
Deactivating.....	7-9
Reactivating.....	7-9
Auxiliary consoles.....	6-9
Auxiliary engineering keyboard.....	1-5, 3-1
B	
BACK.....	7-11
Block details display.....	11-1
C	
Calculator.....	7-15
CASCADE.....	9-11
CMPTR	
DADIG.....	10-20
DANG.....	10-16
STATION.....	9-11
COM'D LINE MENU.....	4-7, 5-8
Command line menu.....	5-8
Console types.....	1-1
Custom log.....	18-2
Activating.....	18-20
Deactivating.....	18-21
Display log.....	18-5
Log status.....	18-16
Print.....	18-5
D	
DADIG	
Control.....	10-19
Element.....	10-17
Force report.....	13-13
Latch reset.....	13-13
On/off report.....	13-13
Suppress/allow alarms.....	13-12
Tag.....	10-17
DANG	
Control.....	10-15
Element.....	10-11

Index (continued)

Force report.....	13-13	Automatics	7-8
On/off report	13-13	Display by name.....	7-8
Suppress/allow alarms	13-12	Display summary.....	7-7
Tag	10-11	Keyboard.....	7-7
Data acquisition		Menus	7-7
Acknowledging control	10-3	Paging	7-11
Analog	10-6, 10-11	Redirecting a display call up	7-10
Common faceplate elements.....	10-3	User task activated.....	7-9
Control inhibit	10-3	Alarm priority indicators	4-6
Digital	10-8, 10-16	Bottom line.....	4-7
Functions.....	10-1	Characteristics	4-3
Initiating control	10-2	Color scheme.....	4-9
Pop ups	7-14	Display system.....	4-1
Select highlight.....	7-14	Escape commands	4-10
Select options.....	7-12	Keyboard status	4-8
Tags	10-2	Operator configurable	16-1
Text string.....	10-20	Pop ups.....	7-14
Data input		Primary display	12-19, 13-9
Alternate language characters	7-5	Select options	7-12
Control prompt/field.....	9-5, 10-5	Standard displays and symbols	4-1
Description	7-4	Title line	4-4
Error checking	7-5	User space.....	4-9
Input field.....	4-7	Display by name	7-8
Making a field active.....	7-4	Display log	18-3
Procedures	7-5	Log by name	18-3
Data messages	2-14	Operation	18-4
Date	20-1	DISPLAY SUMM	7-7
DD		Document conventions	1-11
Control.....	9-19		
Element	9-17	E	
Tag	9-18	ELE	4-10
Description		Error messages	4-7, B-1
Annunciator display panel	1-5	Event log.....	18-1
Color monitor.....	1-4	See system event log	
DECstation	1-3	F	
Disk drives.....	1-6	Features	1-7
Driver unit.....	1-3	FORWD	7-11
Keyboard.....	1-5	Functions	
Keyboard interface panel	1-4	Alarm management	2-7
Main components	1-3	Alternate language.....	2-13
Power entry panel	1-6	Archiving	2-11
Printer.....	1-6	Database	2-6
DETAILS	11-2	Description	2-5
DEVSTAT tag.....	3-12	Diagnostics	2-12
Digital		Display configurator	2-12
Annunciator element	10-8	Logging	2-10
Standard element	10-8	Operations interface	2-5
Disk drives.....	1-6	Operator configurable displays	2-13
DISPLAY	12-13	Process trending	2-9
Display			
Accessing methods	7-7		
ADP	7-7		

Process tuning and configuration	2-12
Security management	2-6
System status	2-12

G

General functions menu	5-1
GENL FCTNS MENU	5-1
Glossary	1-12
Graphical display configurator (GDC).....	4-10

H

How to use this instruction	1-10
-----------------------------------	------

I

IIAKB02	3-1, A-1
IIAKB03	3-1
INFI 90 system	2-1
Communication highway.....	2-1
Engineering work station	2-4
Network interface unit.....	2-4
Operator interface station	2-3
Process control unit	2-2
INFI-NET diagnostics	21-17
Communication module details.....	21-25
Event and error counters	21-26
Exception statistics	21-27
Loop topology	21-21
Node topology.....	21-23
Print network topology	21-29
Printing information.....	21-30
Updating information.....	21-31
Input focus.....	6-2
Instruction content	1-8
Intended user	1-1

K

Key lock.....	7-1
Description.....	1-4
Status.....	4-8
Keyboard	
Accessing displays	7-7
Assignment status	4-8
Auxiliary engineering	1-5, 3-1, A-1
Description.....	1-5
Errors.....	3-2
Layout.....	3-3
Alarm acknowledge/silence	3-10
Alphabetic characters	3-6
Cursor control	3-7

Display control	3-3
Function keys	3-10
Remote control	3-8
Station control	3-8
Trend control	3-7
Operation	3-1
Operator	1-5, 3-1
Status block.....	4-8
Types	3-1

L

LK-201	3-1
Local time.....	20-1
Log	
Custom.....	18-2
SOE.....	18-2
Status	18-14
System event	18-1
Log-in window	8-2

M

MAN/AUTO	
ANALOG	10-8
DADIG	10-20
DANG	10-16
DD	9-20
DIGITAL	10-10
MSDD.....	9-23
STATION.....	9-11
TEXTSTR.....	10-23
MARK.....	7-12
Message window	8-1
MISC MENU	5-8
Miscellaneous menu	5-8
Module	
Configuration.....	22-2
Firmware revision.....	21-13
Problem report	21-12
Status bytes	21-11
Mouse	6-2, 7-13
Buttons	6-2
Moving between screens	6-2
MSDD	
Control.....	9-22
Element.....	9-20
Tag.....	9-20

N

N90STA tag	21-1
NEXT PAGE	7-12

Index (continued)

Note7-15

O

OIS application 6-1
 OIS utilities6-1, 6-13
 OP PARAMS 13-2
 Open access system 19-6
 Operating parameters 13-1
 Alarm inhibit/enable 13-9
 Block details 13-12
 Force report 13-13
 Latch reset 13-13
 On/off report 13-13
 Primary display 13-9
 Problem report 13-12
 Scan off/on 13-9
 Substitute value 13-10
 Analog value 13-10
 Digital state 13-11
 Text string 13-11
 Unsubstitute 13-12
 Suppress/allow alarms 13-12
 Tuning 13-12
 Operating the console 7-1
 Operating theory 2-13
 Operator action requests 17-1
 Operator actions log 18-1
 See system event log
 Operator assignable trend 14-13
 Operator configurable display 16-1
 Alarm summary element 16-3, 16-15
 Box overlap 16-8
 Control element 16-1, 16-8
 Creating 16-3
 Data acquisition element 16-1, 16-8
 Deleting 16-7
 Making permanent 16-17
 Making room for additional 16-18
 Saving 16-7
 Trend element 16-3, 16-12
 Operator information events 17-5
 Operator keyboard 1-5, 3-1
 Option
 Alarm Group Inhibit 12-20
 Archival Storage/Retrieval 19-1
 ASGN PRN 3-12
 CALC 7-15
 Cancel Prints 20-12
 CRT OVRD 7-11
 Display by Name 7-8
 INFI-NET Diagnostics 21-18

Log by Name 18-3
 LOG OUT 7-4
 Log Status 18-15
 LOG/NAME 18-4
 NOTE 7-15
 OIS Configuration 5-1
 OIS Operation 5-1
 OIS Utilities 5-1
 Operating Parameters 13-2
 Operator Action Requests 17-1
 Operator Assignable Trends 14-13
 Operator Configurable Displays 16-3
 Operator Information Events 17-5
 PASSWORD 7-2
 PCU Configuration 22-1
 PRINT 8-11
 Print Database List 13-22, 14-23
 Red Tag Status 22-18, 22-27
 Set Date and Time 20-4
 Tag Historian 19-17, 19-46
 Tag Summaries 13-15
 OUT 9-12
 Overview 1-1, 2-1

P

PAGE ACK 12-13
 Alarm summary 12-19
 Operator action 17-4
 Operator information events 17-6
 System status 21-13
 PAN 14-9
 Password security
 Log-in 7-2
 Log-in status 4-8
 Log-out 7-3
 PCU
 Configuration 22-1
 Management 22-8
 Power entry panel 1-6
 PREV PAGE 7-12
 Print
 Cancel a log 18-22
 Cancel print jobs 20-11
 Custom log 18-5
 Events log 18-8
 INFI-NET diagnostics 21-30
 Log by name 18-3
 Operator actions log 18-8
 PCU configuration 22-13
 Print node 8-3
 Screen 8-3

SOE log	18-8
Tag list	13-22
Tag summaries	13-15
Trend list	14-23
Printer	
Assignment	3-13
Assignment status	4-8
Description	1-6, 3-11
Failover	3-14
Logs	3-12
Print screen	8-3
Cancel	8-12
Configure printer	8-5
Number of copies	8-12
PRINT option	8-11
Screen copy color map	8-12
Screen Copy option	8-11
Select printer	8-5
Private	3-13
Shared	3-13
Status	3-14
Process control	
Acknowledging control	9-3
Common faceplate elements	9-3
Control inhibit	9-3
Device	9-13
Functions	9-1
Initiating control	9-2
Loop control	9-6
Pop ups	7-14
Select highlight	7-14
Select options	7-12
Tags	9-2

Q

Quality	
Alarming	12-10
Indicators	12-6
Alarm inhibit (i)	12-6
Bad (*)	12-7
Good (blank)	12-7
Off scan (x)	12-7
Substituted (s)	12-7
Suspect (?)	12-7

R

RATIO	9-11
RCM	
Control	9-14
Element	9-13

Sequence of events logging	18-6
Tag	9-13
Re-alarmed	12-9
RECALL	7-12
Red tag	
Description	22-16
Descriptor	9-5, 10-5
Dialog box	22-21
Displaying status	22-17
Keys	22-17
Remove	22-20, 22-25
Set	22-19, 22-24
Summary	22-27
Tags	22-16
Reference documents	1-14
Return to normal	12-14
RMCB	
Control	9-26
Element	9-23
Tag	9-24
RMSC	
Control	9-17
Element	9-15
Tag	9-16

S

Sequence of events log	18-2
Activating	18-20
Deactivating	18-21
Display log	18-8
Generating a summary log	18-6
Log status	18-18
Print	18-8
Session manager	6-12
DECwindows	6-10
OIS applications manager	6-10
SET	
DADIG state change	10-20
DANG value change	10-8, 10-11, 10-16
Ratio index change	9-12
RMSC value change	9-17
Set point change	9-11
TEXTSTR input	10-25
Setting input focus	6-2
SHIFT	3-6
SHIFT LOCK	
Description	3-6
Status	4-8
SILENCE	
Alarm relay	12-12
Alarm tone	12-12

Index (continued)

SPACE	3-6
STATION	
Control	9-10
Control output track	9-9
Element	9-6
Manual interlock	9-10
Set point track	9-10
Tag	9-6
Tuning	13-12
Tuning display	11-5
System event log	18-1
Display log	18-9
Note	7-15
Print	18-8
System status	
Acknowledge alarms	21-12
Displays	21-1
INFI-NET diagnostics	21-17
Module status page	21-9
N90STA tag	21-1
Node status page	21-5
System overview page	21-3
SYSTEM STATUS SUMM	21-2
System time	20-1

T

Tag	
Capacity	1-7
Control	9-2
Data acquisition	10-2
Database	2-6
Operating parameters	13-1
Pop ups	7-14
Print tag list	13-22
Red tagging	22-16
Summaries	13-13
Terminal window	8-2
TEXTSTR	
Application driven	10-23
Block driven	10-24
Control	10-23
Element	10-21
Suppress/allow alarms	13-12
Time	20-1
Local	20-1
Synchronization	20-2
System	20-1
Time-stamp	2-22
Console	2-23
Exception report	2-22
Touch pad	8-23

Touch screen	
Calibration	8-18, 8-22
Description	8-14
Operation	7-13, 8-16
Trackball	7-13
Trend	
Control	14-6
Magnifying glass	14-12
Modify scale range	14-8
Move time cursor	14-7
Pan	14-9
Zoom	14-10
Data source	14-1
Description	2-18
Display	
Attributes	14-3
Resolution	14-2
Updates	14-3
Distributed trending	2-18
Enhanced	2-19
Local data collection	2-20
Operator assignable	14-13
Print trend list	14-23
Remote data collection	2-21
Standard	2-19
TUNE	11-6
Tuning	
Block details display	11-1
Functions	11-1
Module configuration	22-6
Station tuning display	11-5
Tuning tags	14-14
Tuning display	
Block details element	11-8
STATION control element	11-8
Trend element	11-8

U

User task	
Description	2-23
Display call up	7-9

W

Windows	
Applications	
Log-in window	8-2
Mail	8-2
Message window	8-1
Auxiliary consoles	6-9
Control buttons	6-6

Icons	6-7
Layout	6-2
Maximize.....	6-6
Menu bar.....	6-4
Move	6-3
Push to back.....	6-4
Session manager.....	6-12
DECwindows.....	6-10
OIS applications manager.....	6-10
Setting input focus	6-2
Shortcut keys.....	6-7
Shrink to icon.....	6-6
Sizing.....	6-9
Title bar.....	6-3
Utilities	
Environment configuration	8-33
Menu bar configuration	8-35
Mouse cursor configuration.....	8-29
Screen copy color map	8-12
Screen copy configuration	8-4
Touch pad configuration	8-25
Touch screen setup	8-15, 8-20
Work area	6-6

X

XY plot	
Background curve	15-5
History	15-7
MFC data plot.....	15-8
Attributes	15-9
Control.....	15-10
Display.....	15-9
Tag plot	15-1
Attributes	15-2
Control.....	15-4
Display.....	15-1
Trend plot	15-1
Attributes	15-2
Control.....	15-4
Display.....	15-1

Z

ZOOM	14-11
------------	-------

Visit Elsas Bailey on the World Wide Web at <http://www.bailey.com>

Our worldwide staff of professionals is ready to meet *your* needs for process automation.
For the location nearest you, please contact the appropriate regional office.

AMERICAS

29801 Euclid Avenue
Wickliffe, Ohio USA 44092
Telephone 1-216-585-8500
Telefax 1-216-585-8756

ASIA/PACIFIC

152 Beach Road
Gateway East #20-04
Singapore 189721
Telephone 65-391-0800
Telefax 65-292-9011

EUROPE, AFRICA, MIDDLE EAST

Via Puccini 2
16154 Genoa, Italy
Telephone 39-10-6582-943
Telefax 39-10-6582-941

GERMANY

Graefstrasse 97
D-60487 Frankfurt Main
Germany
Telephone 49-69-799-0
Telefax 49-69-799-2406